

ISI<sup>®</sup>

2019 CATALOGUE

sparco<sup>®</sup>

**HEADQUARTERS**

**SPARCO S.p.A.**

Via Leini, 524  
10088 Volpiano (TO) - Italy  
Tel. +39 011 22.40.911 - Fax +39 011 22.40.900  
e-mail: info@sparco.it - www.sparco-official.com

**BRANCHES**

**SPARCO MOTOR SPORTS, INC. U.S.A.**

1852 Kaiser Ave. - Irvine, CA 92614  
Tel. (+1)-949-797-1750 - Fax (+1)-949-797-1755  
www.sparcousa.com

**SPARCO INDUSTRIE N.A. SARL**

Semmech Touta km 32,7 GP1 - Grombalia 8030  
Tel. 00216 72215187

sparco<sup>®</sup>

sparco<sup>®</sup>

2019  
CATALOGUE



# QRT TECHNOLOGY

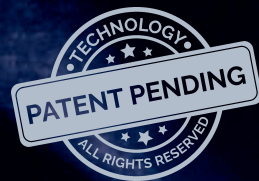

sparco

sparco

CIRCUIT

ADVANCED VACUUM TECH

ULTRA LIGHT-WEIGHT

PROVIDE THE BEST FITTING



\* this picture is from the 2018 Formula 1 season

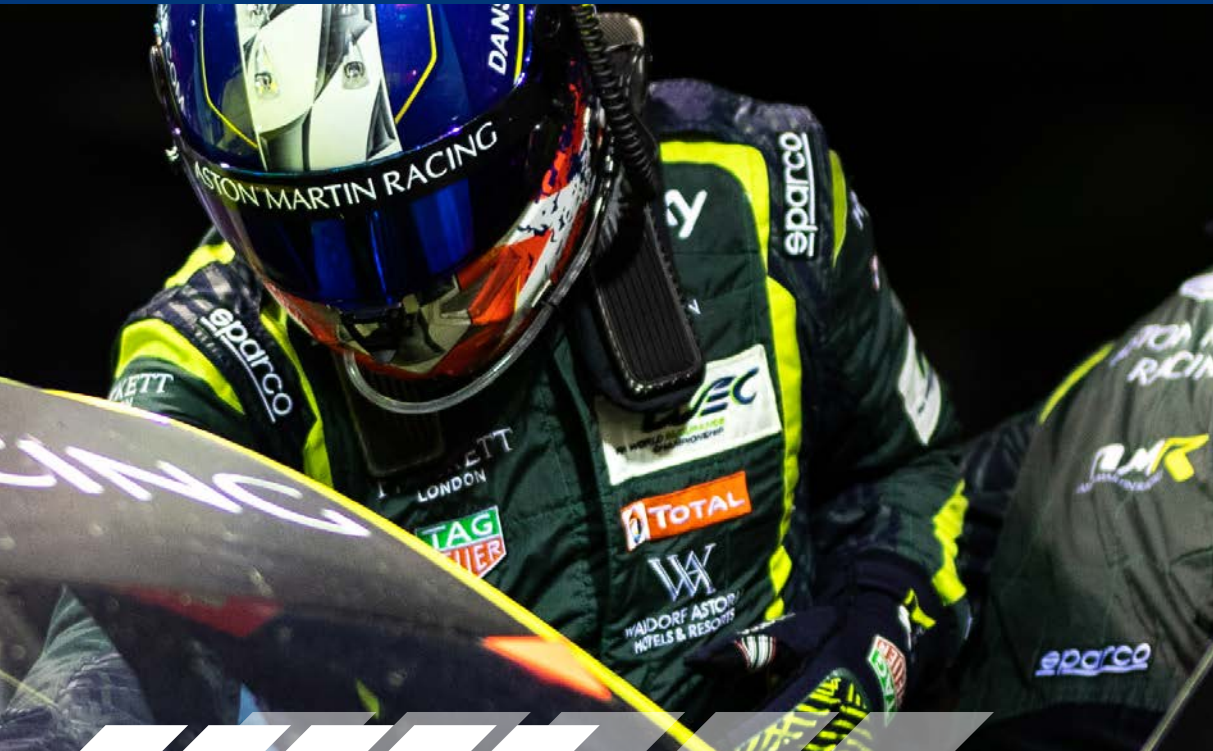







# INDEX

## RACING

52-221

- 052** TUTE/SUITS/MONOS
- 078** UNDERWEAR/UNDERWEAR/ROPA INTERIOR
- 088** SCARPE/SHOES/CALZADOS
- 098** GUANTI/GLOVES/GUANTES
- 106** CASCHI/HELMETS/CASCOS
- 119** ACCESSORI CASCHI/HELMETS ACCESSORIES/ACCESORIOS CASCOS
- 126** HEAD RESTRAINT
- 128** COMUNICAZIONE/COMMUNICATION SYSTEMS/INTERCOMUNICACIÓN
- 132** SEDILI/SEATS/ASIENTOS
- 164** ACCESSORI SEDILI/SEATS ACCESSORIES/ACCESORIOS ASIENTOS
- 166** CINTURE/HARNESSES/CINTURONES
- 178** VOLANTI/STEERING WHEELS/VOLANTES
- 187** ACCESSORI VOLANTI/STEERING WHEELS ACCESSORIES
- 190** IMPIANTI ESTINZIONE/EXTINGUISHING SYSTEMS/EXTINTOR
- 194** ROLL BAR/ROLL CAGES/ARCO DE SEGURIDAD
- 198** ACCESSORI/TACCESSORIES/ACCESORIOS
- 208** MECCANICI/MECHANICS/MECÁNICOS

## KARTING

222-275

- 222** TUTE/SUITS/MONOS
- 242** UNDERWEAR/UNDERWEAR/ROPA INTERIOR
- 248** ARTICOLI BIMBO/KIDS ARTICLES/ARTICULOS INFANTILES
- 249** KART NOLEGGIO/RENTING KART/ALQUILER KARTS
- 250** SCARPE/SHOES/CALZADOS
- 258** GUANTI/GLOVES/GUANTES
- 266** CASCHI/HELMETS/CASCOS
- 272** VOLANTI/STEERING WHEELS/VOLANTES
- 273** ACCESSORI/ACCESSORIES/ACCESORIOS
- 208** MECCANICI/MECHANICS/MECÁNICOS

## PERFORMANCE

276-315

- 276** SEDILI/SEATS/ASIENTOS
- 288** CINTURE/HARNESSES/CINTURONES
- 292** VOLANTI/STEERING WHEELS/VOLANTES
- 304** POMELLI CAMBIO/GEAR KNOBS/POMOS
- 306** PEDALIERE/PEDAL SETS/PEDALES
- 308** ACCESSORI/ACCESSORIES/ACCESORIOS

## TEAMWEAR

316-327

## MERCHANDISING

328-349



# sparco



# RACEWEAR CLOTHING

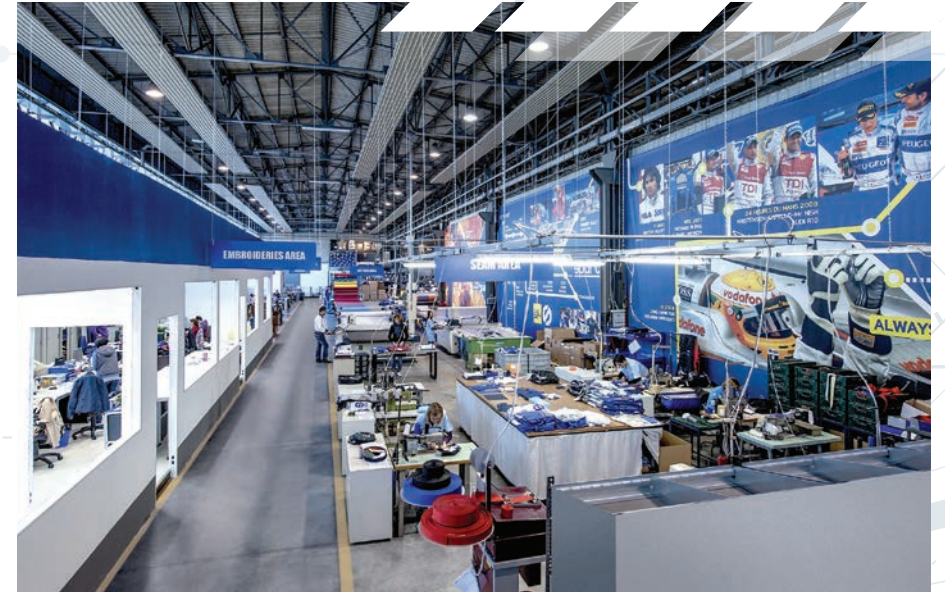

## SEATS & CARBON

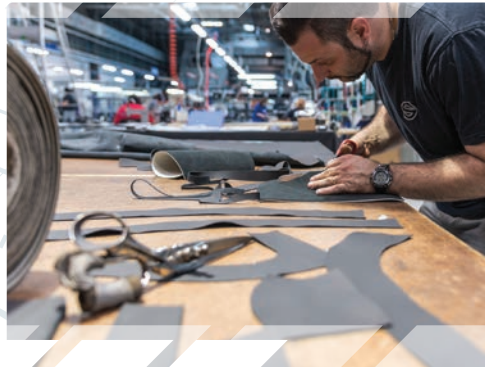

## FACTORY STORE

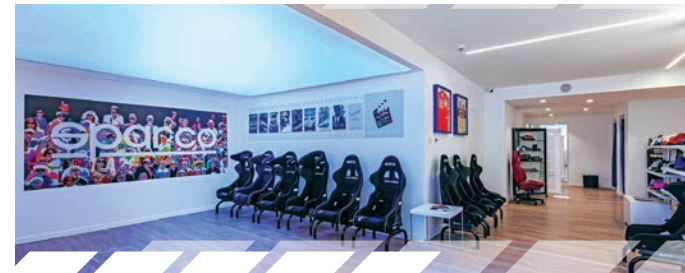

# ON THE TRACK ON THE ROAD

THE FASTEST CARS IN THE WORLD  
ARE EQUIPPED  
WITH SPARCO TECHNOLOGIES



OEM SUPPLIER:



ASTON MARTIN



BENTLEY



## ENGINEERING & DESIGN

Sparco progetta e ingegnerizza alcuni tra i sedili sportivi tecnologicamente più avanzati al mondo. La superiorità dei sedili Sparco proviene dalle scocche disegnate, progettate e sviluppate senza mai perdere di vista la performance. Le nostre scocche vengono progettate utilizzando i software CAD Catia V5 e NX 9. I progetti vengono poi verificati usando i più sofisticati metodi di analisi strutturale FEM&FEA. Sparco sa come progettare al meglio la scocca di un sedile, utilizzando a seconda delle esigenze carbonio prepreg, forgiato a fibra corta, fibra di vetro. Importatissime sono anche le sagome di ogni sedile. I piloti che guidano una Supercar vogliono sedili che permettano loro di "sentire" le prestazioni, l'handling e le reazioni della propria auto, durante la guida sportiva in pista e su strada. Per questo motivo i nostri sedili sportivi sono disegnati su misura, come si fa per una tuta personalizzata che veste ogni pilota al meglio. Sempre più clienti con Supercar vogliono il miglior comfort possibile nelle lunghe distanze, agevolando il più possibile l'esperienza di guida. Ecco perché gli studi ergonomici sono così importanti per gli ingegneri che progettano i sedili Sparco. Sagome e schiume sono la base per avere le prestazioni migliori sotto le massime sollecitazioni della guida al limite, con il supporto di una scocca che sia estremamente leggera e rigida. Da questa combinazione di elementi si ottiene la formula vincente del sedile sportivo Sparco per le Supercar.

Sparco designs and engineers some of the most advanced Sport Seats in the world. The superiority of Sparco seats comes from the shells that are designed, engineered and developed with performance in mind. Our seat shells are designed using Catia 5 and NX 9 CAD software. Then the project is verified using the most sophisticated FEM & FEA structural analysis methods. Sparco knows how to design the best seat shells, whether in prepreg carbon, forged carbon or glass fiber. But the shape is just as important in a sport seat. Supercar drivers want seats that allow them to "feel" the performance, the handling and the behavior of the car while racing or fast driving. Therefore, our sport seats are designed like customized suits that fit each driver at best. But the demanding Supercar customers also want the best possible comfort, for long distance, and for as smooth as possible driving experience. This is why ergonomic studies are so important for the engineers who design Sparco seats. A good trim and foam design is the foundation for high speed performance as much as a light and rigid shell. Together they form the winning combination of the Sparco sport seat for Supercars.

## SEATS

Sparco ha iniziato a produrre sedili sportivi OEM (Original Equipment Manufacturer) nel 1998 per la Lamborghini Diablo. Sparco ha studiato, progettato e sviluppato il primo sedile sportivo regolabile in fibra di carbonio per le Supercar superando brillantemente le prove di omologazione e i test di sicurezza e durata delle più importanti case automobilistiche. Da allora, fino ai giorni odierni, Sparco è fornitore di marchi prestigiosi come Lamborghini, Ferrari, Bugatti, Aston Martin, Bentley, Audi, McLaren Cars, AMG Mercedes Benz, Alfa Romeo, Lotus Cars, Koenigsegg, Maserati, Ford GT, Mini John Cooper Works and many more sport and supercar makers. Sparco seats for Supercars have the same DNA, the same engineering and capability of the Sparco racing seats. They are light, thin yet safe and comfortable. Furthermore, Sparco Sport Seats for Supercars are often luxuriously trimmed in sporty Alcantara or in the most exclusive and expensive leathers. Since 2010, Sparco offers Sport seats for Supercars with Side Bag, up to 12 way Power assisted adjustments, Heating and Cooling systems and comfort features like Lumbar Adjusters. And, as the technological innovation never stops, Sparco has gained the leadership by being the first to offer short fiber technology for the most complex yet lightest sport seats. Today, Sparco is the only manufacturer that offers seats with side airbags wrapped by a real carbon fiber cover, granting an uninterrupted look and the highest safety standards.

Sparco started manufacturing Sport Seats in OEM in 1998 for the Lamborghini Diablo. Sparco studied, designed and developed the first adjustable sport seat in Carbon Fiber for Supercars, satisfying the safety & durability requirements of the most demanding car makers. Since those days, Sparco supplied sport seats to Lamborghini, Ferrari, Bugatti, Aston Martin, Bentley, Audi, McLaren Cars, AMG Mercedes Benz, Alfa Romeo, Lotus Cars, Koenigsegg, Maserati, Ford GT, Mini John Cooper Works and many more sport and supercar makers. Sparco seats for Supercars have the same DNA, the same engineering and capability of the Sparco racing seats. They are light, thin yet safe and comfortable. Furthermore, Sparco Sport Seats for Supercars are often luxuriously trimmed in sporty Alcantara or in the most exclusive and expensive leathers. Since 2010, Sparco offers Sport seats for Supercars with Side Bag, up to 12 way Power assisted adjustments, Heating and Cooling systems and comfort features like Lumbar Adjusters. And, as the technological innovation never stops, Sparco has gained the leadership by being the first to offer short fiber technology for the most complex yet lightest sport seats. Today, Sparco is the only manufacturer that offers seats with side airbags wrapped by a real carbon fiber cover, granting an uninterrupted look and the highest safety standards.



## QUALITY

La qualità dei sedili sportivi Sparco non è solo "la ciliegina sulla torta" del processo produttivo, ma è una predisposizione mentale che inizia con la progettazione di un sedile e attraversa tutti i processi produttivi fino al termine della produzione e relativo controllo. Sedili e parti in carbonio sono progettati secondo la metodologia DFMEA e PFMEA, che consente di rilevare e correggere possibili errori in fase di progettazione e produzione prima che questi si verifichino. A seguito di questi controlli vengono avviati i test di qualifica e le pratiche per l'approvazione del prodotto, secondo le esigenti metodologie PPAP imposte dalle case automobilistiche. Sparco è certificata ISO/TS:16949 per tutta la parte dello sviluppo del design e della produzione di sedili e componenti in fibra di carbonio. Al di sopra di questo impianto di base, ogni produttore di Supercar ha le proprie richieste, che il team della qualità Sparco implementa e armonizza con i nostri processi. Solo il meglio, per le vetture più sofisticate del pianeta.

The Quality on Sparco sport seats is not only the "cherry on top" of the production process, but is a mindset that starts from the design of the seat and goes through the various manufacturing processes until the end of line product checks. Seats and carbon parts are designed according to DFMEA and PFMEA methodology, that allow to detect potential mistakes in design and process before they happen. Then, the test for qualification and product approval are carried out according to the demanding PPAP procedures used by the world class car industry. Sparco applies the ISO/TS:16949 Quality System in all the steps of the seat and carbon fiber design, development and manufacturing. On top of this method, each of the supercar makers has its own requirements, that our quality team implements and matches with our processes. Only the best, for the most sophisticated cars of the planet.

## CARBON TECHNOLOGY

La Fibra di carbonio è il materiale più avanzato usato dall'industria automobilistica. Incredibilmente leggera e resistente, la fibra di carbonio è stata creata per l'industria aerospaziale e militare e introdotta in F1 dal geniale fondatore della Lotus, Colin Chapman, nel 1981 sulla vettura di F1 Lotus 88. Sparco ha iniziato ad utilizzare la fibra di carbonio per i suoi sedili racing nel 1984 e da allora non ha mai smesso di progettare e sviluppare i sedili da corsa tecnicamente più avanzati. Nel 1999 Sparco ha creato una divisione per la produzione di particolari in fibra di carbonio e sedili sportivi, messa a disposizione dei costruttori di Supercar e dell'industria aerospaziale. Oggi 9 autoclavi (2 autoclavi sono state aggiunte nel 2014) e oltre 250 dipendenti lavorano per realizzare parti in carbonio per Supercar come la Lamborghini Aventador, l'Alfa Romeo Giulia QV, molti modelli di Aston Martin, così come parti per super jet come l'Airbus A380. La fibra di carbonio non è un materiale facile da lavorare. Ha un comportamento molto complicato e poco lineare: richiede un approccio ingegneristico e un design sofisticato per generare componenti leggeri e resistenti, usati in applicazioni estreme come le vetture da corsa, le Supercars e gli aeroplani. Nel 2014 Sparco ha affiancato alla tecnologia del prepreg in autoclave la lavorazione in pressa sia del prepreg che del materiale a fibra corta. Questa nuova tecnologia consente di ridurre i tempi di produzione, aumentando la capacità produttiva senza rinunciare alle ottime prestazioni della fibra di carbonio.

Carbon Fibre is the most advanced material used in the automotive industry. Incredibly light and strong, Carbon Fibre was created as an aerospace and military material and introduced in F1 by the ingenious founder of Lotus, Colin Chapman, in 1981 on the Lotus 88 F1 car. Sparco started using carbon fibre for its racing seats in 1984 and since then never stopped designing the most technically advanced racing seats. In 1999 Sparco created a dedicated carbon fibre and sport seats division, devoted to supplying the Supercar and aerospace industry. Today, 9 autoclaves (2 autoclaves have been added in 2014) and over 250 employees are working to create carbon parts for supercars like the Lamborghini Aventador, the Alfa Romeo Giulia QV as well as parts for superjets like the Airbus A380. Carbon Fibre is not an easy material to deal with. It has a complicated, non-linear stress behavior and requires a sophisticated design and engineering approach to generate the light and strong parts used in extreme applications like racing cars, supercars and planes. In 2014 Sparco has added the pressed carbon fiber technology. This new technology reduces the production time, increasing Sparco's production capacity while maintaining the excellent performance of the carbon fibre materials.



# CUSTOMIZATIONS



**CUSTOMIZATIONS**

# **CUSTOM EASY**

- **IMAGINE**
- **CUSTOMIZE**
- **CREATE**



## **5 EASY STEPS TO CREATE YOUR OWN SUIT**

- 1**  **CHOOSE YOUR SUIT**
- 2**  **SELECT YOUR DESIGN**
- 3**  **PICK YOUR COLOURS**
- 4**  **FIND YOUR SIZE**
- 5**  **ADD YOUR LOGOS**

**CREATING YOUR CUSTOM SUIT  
HAS NEVER BEEN SO EASY!**



# CUSTOM EASY

Un nuovo strumento creato da Sparco per aiutarti nella personalizzazione della tua tuta. Semplice e veloce, con Custom Easy puoi scegliere tra 5 modelli, 11 soluzioni di design e molteplici combinazioni di stile.

Alcuni semplici passi: seleziona il modello, identifica il design che preferisci, scegli i colori, scegli la tua taglia e aggiungi i tuoi loghi. La tua tuta è pronta!

A new tool created by Sparco to help you customise your suit. Quick and easy, with Custom Easy you can choose from 5 models, 11 design solutions and multiple style combinations.

Just a few simple steps: select the model, identify your preferred design, choose the colours, select your size and add your logos. Your suit is ready!

Un nuevo instrumento creado por Sparco para ayudarte a personalizar tu mono. Simple y rápido, con Custom Easy puedes escoger entre 5 modelos, 11 soluciones de diseño y múltiples combinaciones de estilo.

Unos simples pasos: selecciona el modelo, identifica el diseño que prefieres, selecciona los colores, selecciona tu talla y añade tus logotipos. Tu mono ¡está listo!



**FOR MORE INFORMATION CONTACT YOUR DEALER  
OR WRITE TO [CUSTOMEASY@SPARCO.IT](mailto:CUSTOMEASY@SPARCO.IT)**

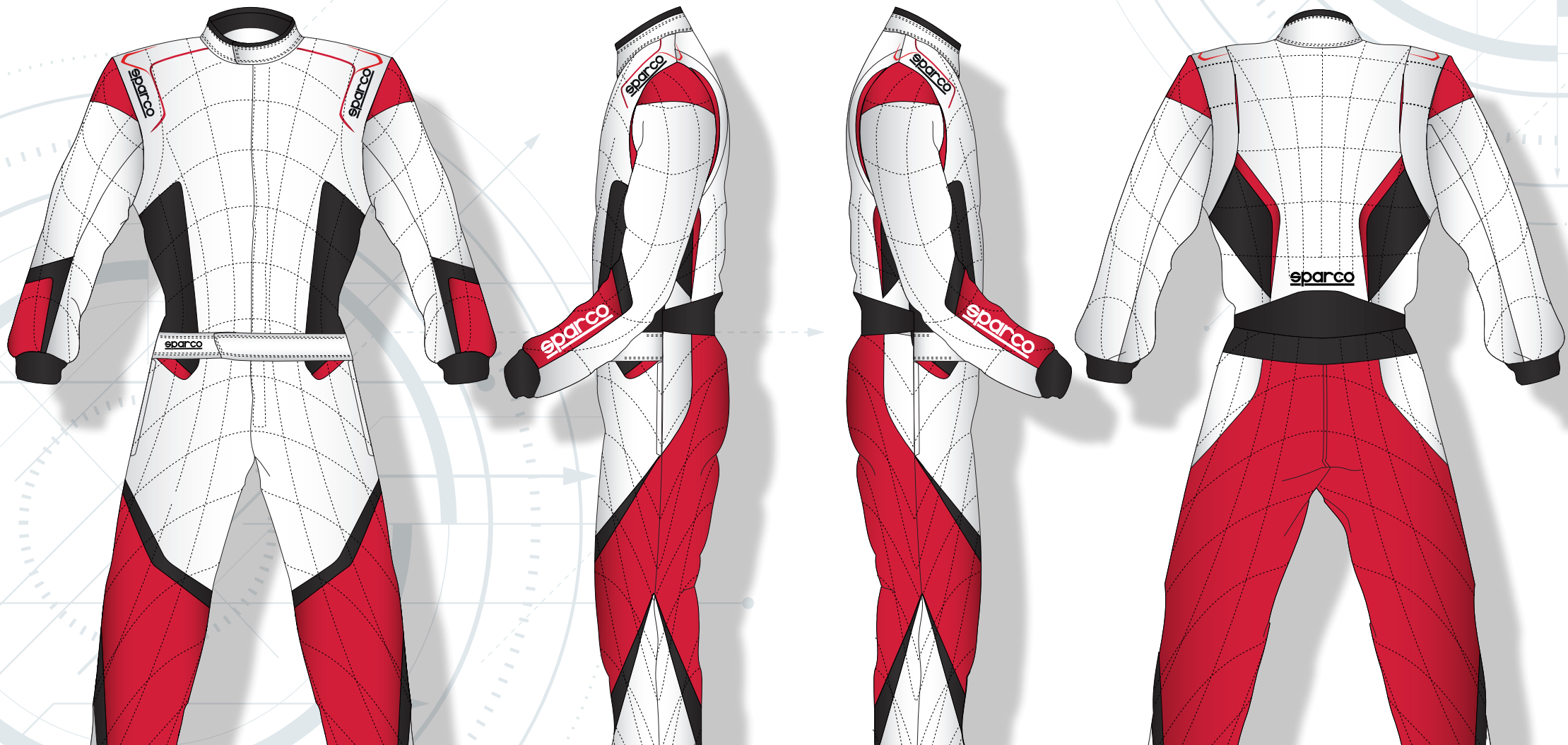

# CUSTOMIZATIONS

## 3D CONFIGURATOR

La personalizzazione a portata di un click: l'innovativo configuratore Sparco. L'unico configuratore on-line che ti permette di personalizzare tute, guanti, scarpe e sedie comodamente dal tuo pc o dal tuo smartphone. Scegli la configurazione più adatta alle tue esigenze, conferma il tuo ordine e ricevi il prodotto direttamente a casa tua. Per maggiori info contatta il tuo shop di fiducia o visita il nostro sito [www.sparco-official.com](http://www.sparco-official.com)

Customisation that's just a click away: the innovative Sparco configurator. The only online configurator that enables you to conveniently customise suits, gloves, shoes and seats from your PC or smartphone. Choose the configuration most suited to your needs, confirm your order and have the product delivered straight to your door. For more info contact your favourite shop or visit our website [www.sparco-official.com](http://www.sparco-official.com)

La personalización al alcance de un clic: el configurador Sparco innovador. El único configurador on-line que te permite personalizar monos, guantes, calzados y sillas cómodamente desde tu PC o tu smartphone. Escoger la configuración más adecuada para tus exigencias, confirmas tu pedido y recibes el producto directamente en tu casa. Para más información contacta con tu tienda de confianza o visita nuestro sitio web [www.sparco-official.com](http://www.sparco-official.com)

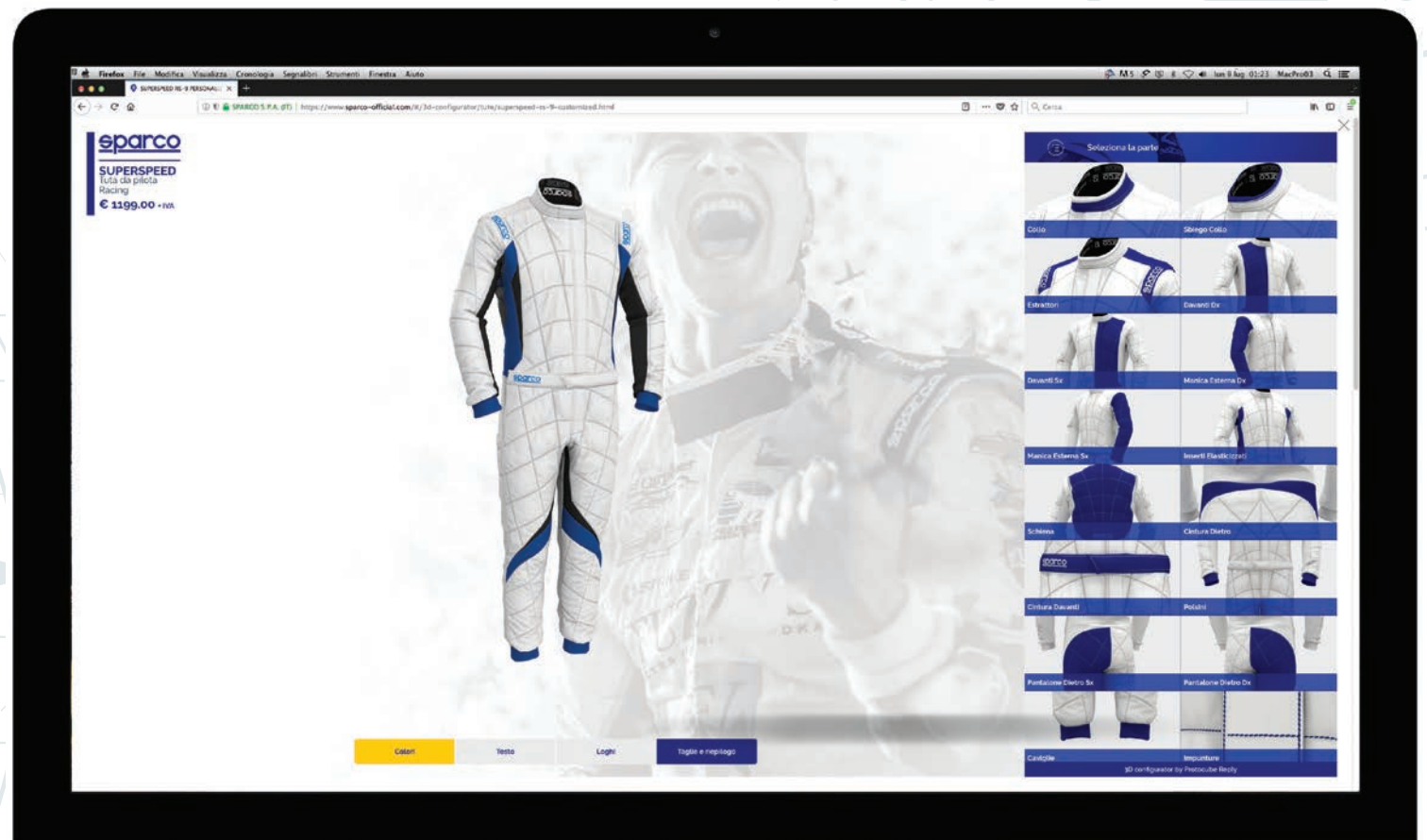

[www.sparco-official.com](http://www.sparco-official.com)

CUSTOMIZATIONS

# INFINITY PROJECT

NEVER  
ENDING  
POSSIBILITIES



[infinty@sparco.it](mailto:infinty@sparco.it)





MANUFACTURER: SPARCO  
MODEL: R553  
HOM. NO: TBD  
FIA STANDARD: 8856-2018

Homologation: FIA 8856-2000

Taglia • Size • Tamaño: ON DEMAND

0011028SP € ON DEMAND

Una tuta unica, la tua tuta INFINITY. La prima tuta ignifuga al mondo completamente personalizzabile, nessun freno all'immaginazione! Costruita con un nuovo tessuto stampabile per sublimazione, molto più leggero e resistente di prima, creatività e fantasia renderanno la tua INFINITY un prodotto unico al mondo!

A unique suit, your INFINITY suit! The world's first completely customisable flame-resistant suit, unleash your imagination! Constructed in a new dye-sublimation printable fabric, much lighter and tougher than before, your creativity and imagination will make your INFINITY product absolutely unique!

Un mono unico, tu mono INFINITY. El primer mono ignifugo del mundo completamente personalizable, ningún límite a la imaginación! Construido con un nuevo tejido imprimible por sublimación, mucho más ligero y resistente que antes, la creatividad y la fantasía harán que tu mono INFINITY sea un producto único en todo el mundo!



MANUFACTURER: SPARCO  
MODEL: SUPERLEGGERA RB-10.1  
FIA STANDARD: 8856-2000

Homologation: FIA 8856-2000

Taglia • Size • Tamaño: ON DEMAND

0012371NFSP € ON DEMAND



**CARATTERISTICHE:** scarpa derivata dalla Superleggera, interamente in pelle di canguro, senza inserti, completamente personalizzabile per mezzo di stampa diretta, con zone traforate per massima traspirabilità.

**FEATURES:** shoe derived from the Superleggera made entirely in kangaroo leather, without inserts, fully customisable through direct printing, with perforated areas for maximum breathability.

**CARACTERÍSTICAS:** calzado derivado del Superleggera, completamente en piel de canguro, sin insertos, completamente personalizable mediante impresión directa, con zonas caladas para ofrecer la máxima transpirabilidad.



MANUFACTURER: SPARCO  
MODEL: RG-7  
FIA STANDARD: 8856-2000

Homologation: FIA 8856-2000

Taglia • Size • Tamaño: ON DEMAND

001309SP € ON DEMAND



**CARATTERISTICHE:** Precurvato. Tessuto monostrato su dorso e forchette traspirante e leggero. Cuciture esterne. Dorso e dita preformate. Elastico nel polsino. Sagomatura ergonomica del pollice. Tecnologia unica e brevettata FR: Touch Sensitive su indice e pollice. Palma in tessuto doppio stampato con tecnologia HTX. Imbottitura nella zona carpale del palmo per ridurre impatti. Personalizzabili dal pronto.  
**PERSONALIZZAZIONE:** stampa transfer.

**CHARACTERISTICS:** Pre-curved. Single-layer fabric on the back and between fingers, breathable and light. Back and fingers preformed, elastic wrist. Ergonomic profiling. Unique and FR patented technology: Touch Sensitive on index and thumb. Palm made of double-layer fabric using HTX technology, padding in the carpal region of the palm to reduce impact damage. New back graphic ready for personalisation.  
**PERSONALISATION:** transfer print.

**CARACTERÍSTICAS:** Curvado de antemano. Tejido de una sola capa al dorso transpirable y ligero. Costuras externas. Dorso y dedos formados de antemano. Forma ergonómica del pulgar. Tecnología única y patentada FR: Touch Sensitive en índice y pulgar. Palma de tejido doble estampado con tecnología HTX. Acolchado en la zona carpiana de la palma para reducir los impactos.  
**PERSONALIZACIÓN:** estampado transfer.

# TABELLE MISURE STANDARD - STANDARD SIZE CHARTS CUADROS ESTANDAR MEDIDA

SUITS - KID BODY SIZE CHART / TABELLA MISURE FISICHE PER BAMBINO														
KID	CHEST CIRCUMFER. circonferenza torace	WAIST CIRCUMFER. circonferenza vita	PELVIS CIRCUMFER. circonferenza bacino	THIGH CIRCUMFER. circonferenza gamba	SHOULDER WIDTH larghezza spalle	SLEEVE LENGHT lunghezza manica	FRONTAL CHEST LENGHT lunghezza busto davanti	EXTERNAL LEG LENGHT lunghezza esterno gamba	INSEAM LEG LENGHT lunghezza interno gamba	BACK LENGHT lunghezza dietro	NECK CIRCUMFER. circonferenza collo	lunghezza cavallo totale	HEIGHT altezza	WEIGHT peso
	cm	cm	cm	cm	cm	cm	cm	cm	cm	cm	cm	cm	cm	kg
età / taglia	A	B	C	D	E	F	G	H	L	M	N	P		
6-7 / 120	60-63	55-60	69-71	37-39	28-30	44-47	41-44	67-71	52-54	29-31	32-34	104-106	116-125	20-23
8-9 / 130	64-67	61-63	72-75	40-42	31-33	48-51	45-48	75-79	57-60	32-34	34-36	107-110	126-135	24-28
10-11 / 140	68-71	64-67	76-79	43-44	34-36	52-55	49-52	83-87	63-66	35-37	37-39	111-113	136-145	29-36
12-13 / 150	72-75	68-71	80-83	45-47	37-39	56-59	53-56	91-95	69-72	38-41	40-42	114-117	146-155	37-44

SUITS - MAN BODY SIZE CHART / TABELLA MISURE FISICHE PER ADULTO														
MAN	CHEST CIRCUMFER. circonferenza torace	WAIST CIRCUMFER. circonferenza vita	PELVIS CIRCUMFER. circonferenza bacino	THIGH CIRCUMFER. circonferenza gamba	SHOULDER WIDTH larghezza spalle	SLEEVE LENGHT lunghezza manica	FRONTAL CHEST LENGHT lunghezza busto davanti	EXTERNAL LEG LENGHT lunghezza esterno gamba	INSEAM LEG LENGHT lunghezza interno gamba	BACK LENGHT lunghezza dietro	NECK CIRCUMFER. circonferenza collo	HEIGHT altezza	WEIGHT peso	
	cm	cm	cm	cm	cm	cm	cm	cm	cm	cm	cm	cm	kg	
size / taglia	A	B	C	D	E	F	G	H	L	M	N			
XS	44	86-89	74-77	86-89	45-48	37-40	54-57	62-64	97-100	72-74	41-43	37-38	164-167	54
	46	90-93	78-81	90-93	47-50	39-42	56-59	64-66	98-101	73-75	42-43	38-39	167-170	60
S	48	94-97	82-85	94-97	49-52	41-44	58-61	66-68	99-102	74-76	42-44	39-40	170-173	66
	50	98-101	86-87	98-101	51-54	42-46	60-63	68-70	100-103	75-77	43-44	40-41	173-176	72
M	52	102-105	88-93	102-105	54-57	45-48	62-65	70-72	101-104	76-78	44-45	41-42	176-179	78
	54	106-109	94-97	106-109	56-59	47-50	64-67	72-74	102-105	77-79	45-46	42-43	179-182	84
L	56	110-113	98-101	110-113	59-62	49-52	66-69	74-76	103-106	78-80	46-48	43-44	182-185	90
	58	114-117	102-105	114-117	61-64	51-54	68-71	76-78	103-107	79-81	48-49	45-46	185-188	96
XL	60	118-121	106-109	118-121	64-67	53-56	70-73	78-80	105-108	80-82	49-51	46-47	188-191	102
	62	122-125	110-113	122-125	67-70	56-58	72-75	80-82	107-110	81-83	51-52	47-48	191-194	108
XXL	64	126-129	114-117	126-129	69-72	57-60	74-77	82-84	108-111	82-84	52-54	49-50	194-197	114
	66	130-133	118-121	130-133	72-75	59-62	76-79	84-86	109-112	83-85	53-55	51-52	197-200	120

NB: If Your measurements differ from standard size, please verify with a tailor measuring tape and complete the Driver's chart measurements; It's recommended also complete the optional measures.  
Please note that these physical measurements charts are indicative only for commercial purposes, then are useful for Sparco products.  
Note only for the kids' product sizes: Take into account any uses of chest protectors and its related footprint.

\* FOR THE LADY SIZE CHART VISIT OUR WEBSITE [WWW.SPARCO-OFFICIAL.COM](http://WWW.SPARCO-OFFICIAL.COM)

GLOVES									
Hand (inches)	3-4½	4-5½	5-6½	6-7½	7-8½	8-9½	9-10½	10-11½	11-12½
Hand (cm)	7½-10½	10-14	12½-16½	16½-19	18-21½	20-24	23-26½	25½-29	28-32
Letter sizes	XXXXXS	XXXS	XXS	XS	S	M	L	XL	XXL
Number sizes	5	6	7	8	9	10	11	12	13

To determine your size, it is recommended to measure the dominant hand (e.g. the right hand if you are right handed) as this will typically be larger. Measure around the largest part of the hand over knuckles while making a fist, excluding thumb.

SHOES														
UK	3½	4	5	5½	6½	7	8	9	9½	10½	11	12	13	14
US	4½	5	6	6½	7½	8	9	10	10½	11½	12	13	14	15
Continental	36	37	38	39	40	41	42	43	44	45	46	47	48	49
Japanese (cm)	23	23½	24	24½	25	26	27	28	28½	29½	30	31	32	33

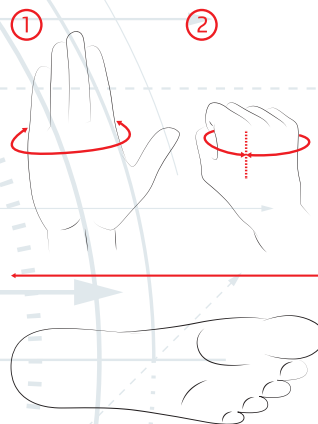

# SCHEMA TUTE SU MISURA - MADE-TO-MEASURE CHART CUADRO MONO A MEDIDA

### A THORAX CIRCUMFERENCE

cm:

Use a tape measure, run under armpit, put in the largest part of the chest in horizontal position, arms at your sides.

### B WAIST CIRCUMFERENCE

cm:

Run tape measure around waist horizontally, arms at your sides.

### C PELVIS CIRCUMFERENCE

cm:

Run tape measure around basin in the largest point, arms at your sides. Put the tape measure 18-20 cm under waist point.

### D THIGH CIRCUMFERENCE

cm:

Run tape measure around the thigh horizontally, try to measure the largest part of the thigh. You should be around 10 cm from the crotch.

### E SHOULDER WIDTH

cm:

Arms at your sides, run tape measure from bone to bone. It is important that the tape is rigid in order to obtain a proper measure.

### F SLEEVE LENGTH

cm:

Start the measurement from shoulder bone, running the tape measure around elbow (arm slightly flexed) until wrist bone.

### G FRONTAL CHEST LENGTH

cm:

Take the measure starting from the notch of the neck to the front of crotch (reference stitch of the underwear). It is important to put the tape measure in the correct position, always keeping in tension in a vertical position.

### H EXTERNAL LEG LENGTH

cm:

Put tape measure laterally, and run the tape measure from waist to ankle bone.

### I INTERNAL LEG

cm:

Run tape from crotch to internal ankle bone.

### J REAR LENGTH

cm:

Run the tape measure from lower vertebra of the neck to the waist (see point 2).

### K NECK CIRCUMFERENCE

cm:

Run your tape measure around the neck and close the circle. Please indicate in the space below the value in centimeters.

### L BICEPS CIRCUMFERENCE

cm:

Run the tape measure around the widest point of the biceps. Close the circle with the tape measure and indicate in the space below the value in centimeters.

### M TOTAL CROTCH LENGTH

cm:

Take the measuring tape and put it in front of your body. The measurement should be taken starting from the notch of the neck to the lower vertebra of the neck, passing by the horse. The tape should then have a complete round from the front to the back.

Name:

Surname:

Height (cm):  Weight (kg):

Do not forget to indicate total height and weight of the driver.



SIZE MEASUREMENTS TUTORIAL  
<https://www.youtube.com/watch?v=K3sV4MaQdAY>

**PRIME / PRIME+**

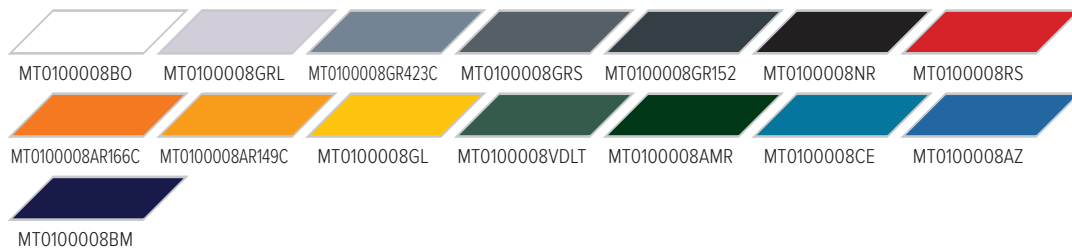

**SUPERSPEED**



**EAGLE**

MAIN FABRIC



SECONDARY FABRIC

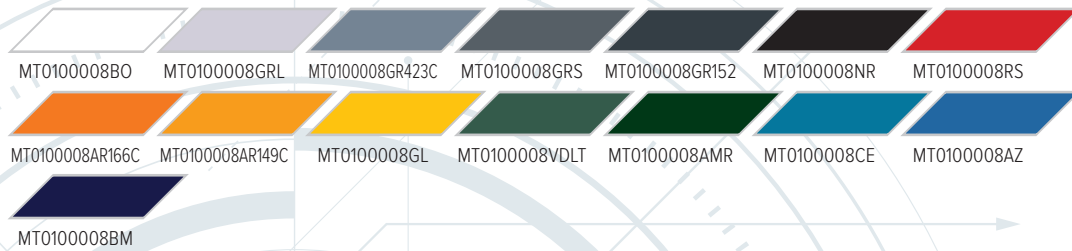

**VICTORY**

MAIN FABRIC



SECONDARY FABRIC

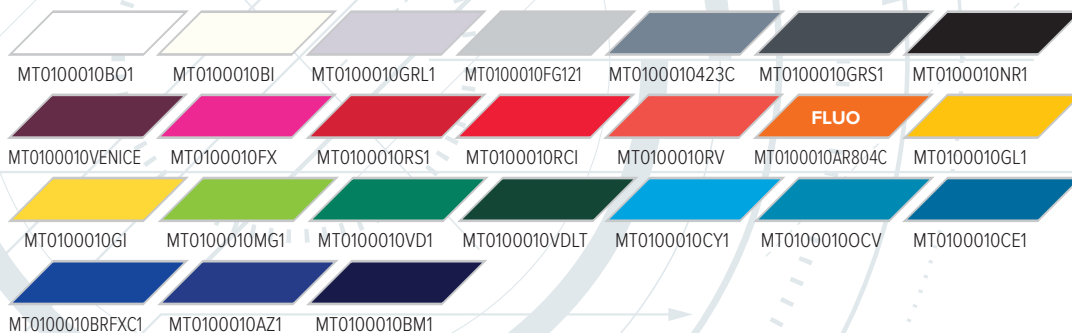

**COMPETITION+ / LADY / VINTAGE**

MAIN FABRIC

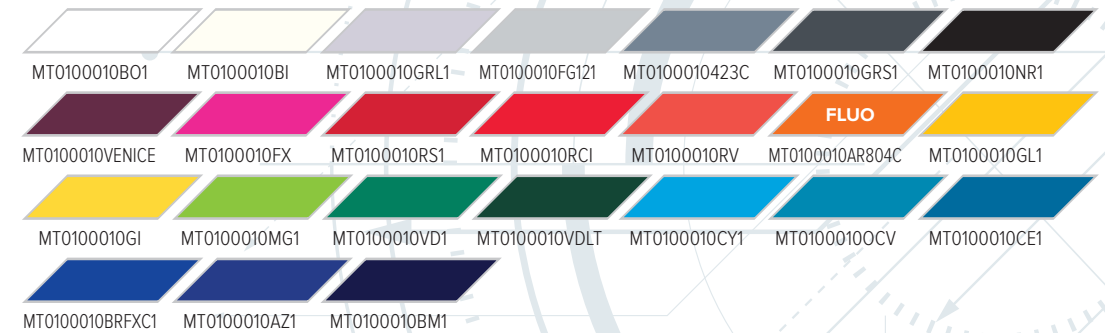

SECONDARY FABRIC



**COMPETITION**

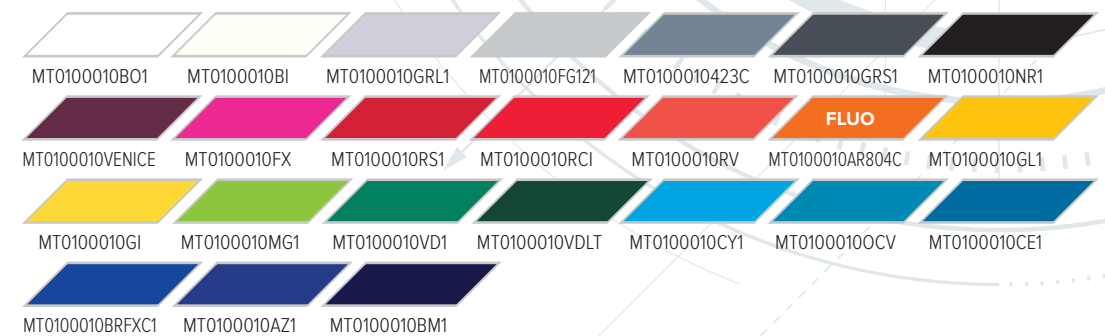

**SPRINT**



**CONQUEST**

MAIN FABRIC



SECONDARY FABRIC

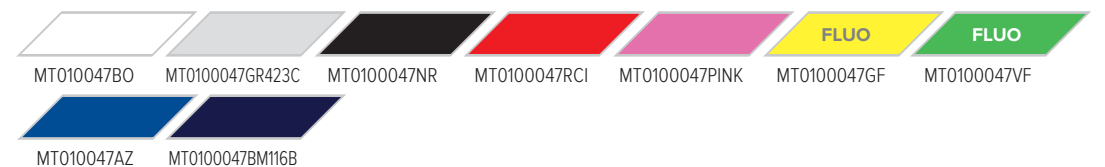

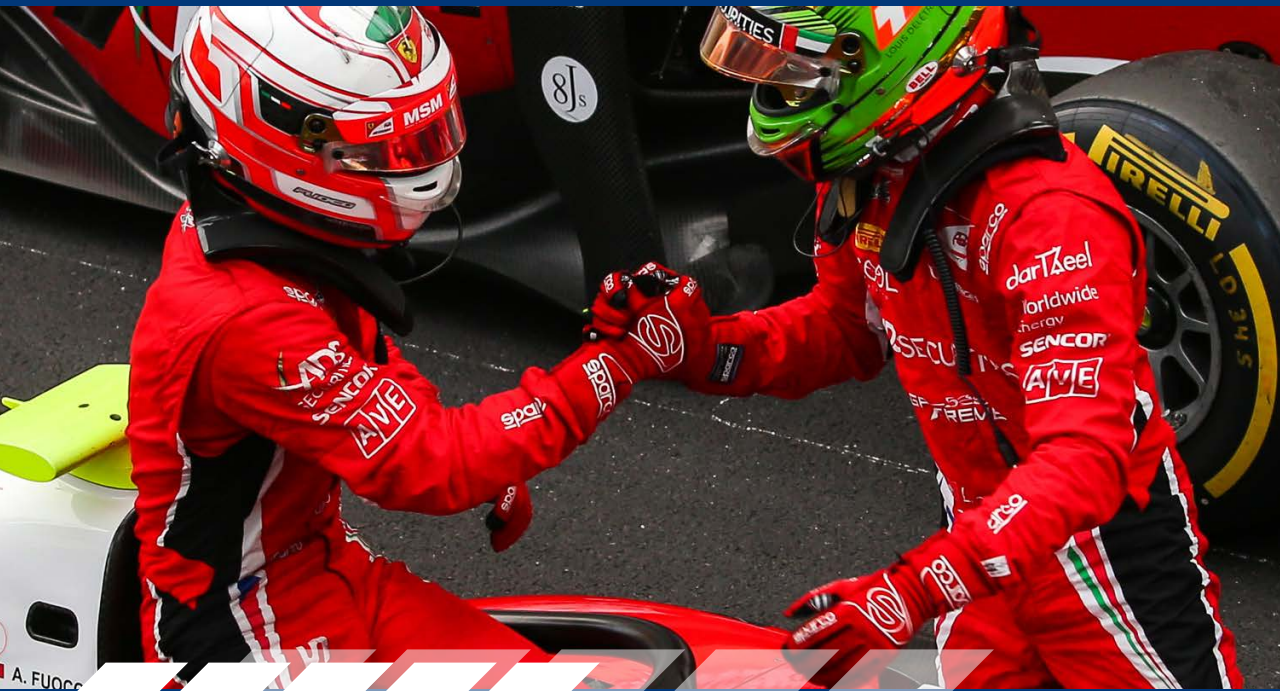

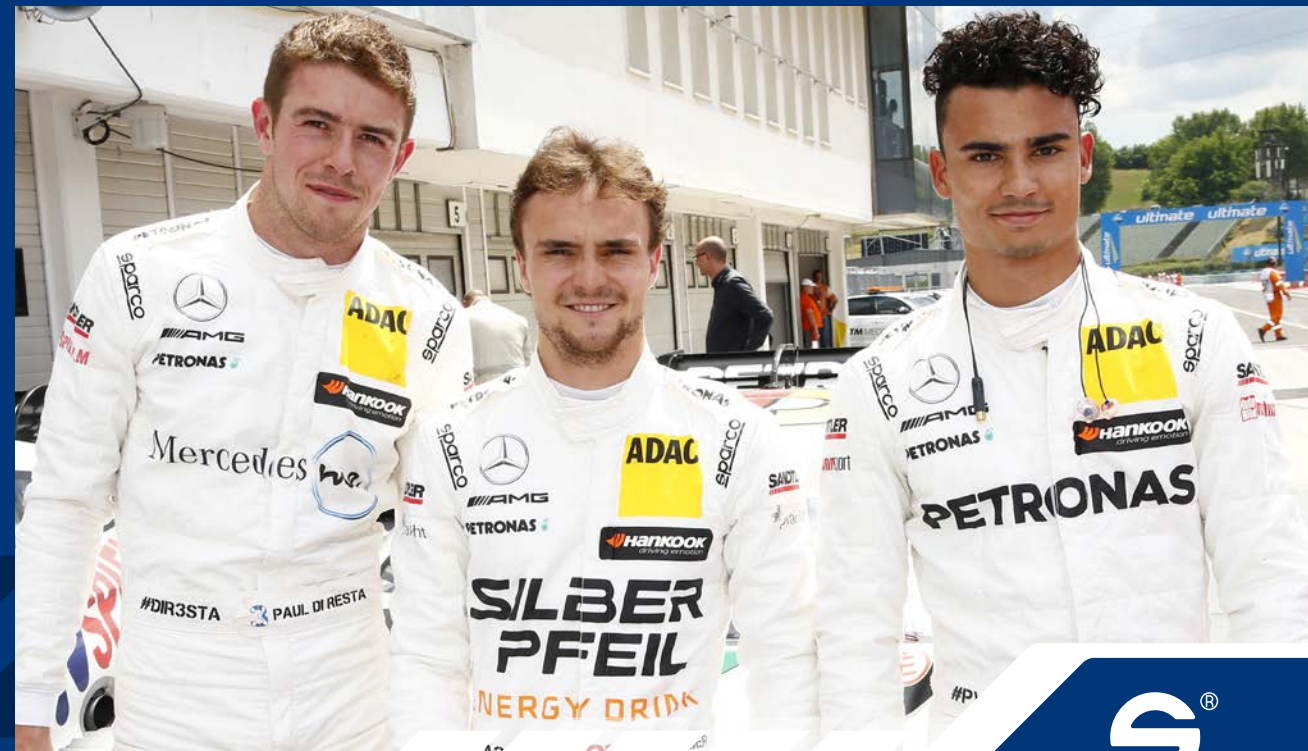





\* the pictures are from season 4

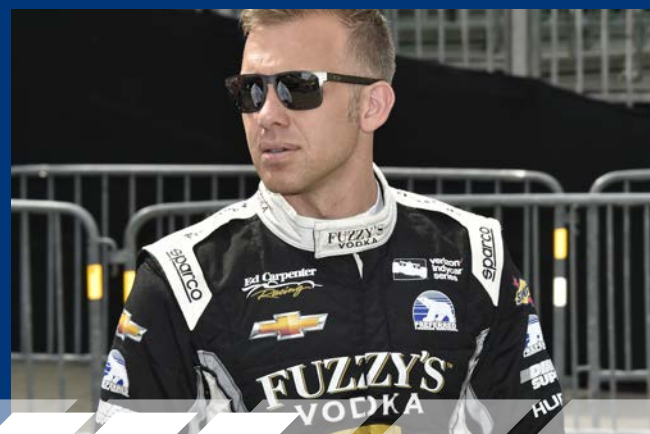
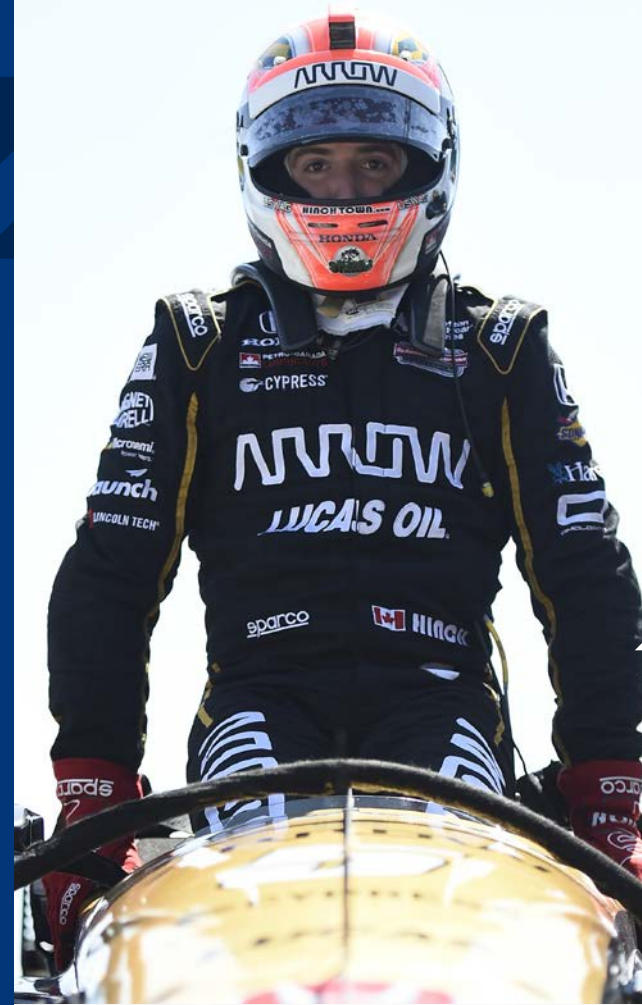



RACING

# SUITS



ISI<sup>®</sup>



MANUFACTURER: SPARCO  
 MODEL: R547-PRIME SP16-SPEC2  
 HOM. NO.: RS.282.16  
 FIA STANDARD: 8856-2000

**ON DEMAND**

**PRIME ⊕**

Homologation: FIA 8856-2000

Peso • Weight • Peso: 240/270 g/m<sup>2</sup>

Taglia • Size • Tamaño: 48-66

€ ON DEMAND

Prime SP-16+, realizzata in collaborazione con il Team McLaren F.1, è la tuta racing omologata FIA più leggera di sempre. Prime Sp-16+ ha un'anima tecnologica che non ha uguali al mondo: realizzata negli uffici R&D Sparco, ha un peso di soli 590 grammi (taglia 52) ed una vestibilità mai provata prima. Sono solo 2 gli strati della Prime SP-16+ che permettono una traspirabilità massima. Il progetto è stato studiato ottimizzando qualsiasi tipo di dettaglio: la cerniera ultra slim, polsini e caviglie sono seamless in Nomex/Viscosa, il collo e le spalline sono stati ulteriormente ridotti, il cucirino è stato assottigliato mentre le cuciture sono state appiattite ancora di più. Prime SP-16+, una tuta unica pensata per un uso sempre più estremo e personalizzato per prestazioni al limite.



The Prime SP-16+ is made in collaboration with the McLaren F.1 Team and is the lightest ever FIA approved racing suit. The Prime Sp-16+ has unparalleled technological features: created in the Sparco R&D laboratories, it weighs only 590 gram (size 52) and is unbelievably comfortable. The Prime SP-16+ has just 2 layers which makes it highly breathable. The project involved optimising every single detail including the ultra slim zip, seamless Nomex/Viscosa wrists and ankles, reduced neck and shoulder pads, thinner thread and more flattened stitching. The Prime SP-16+ is a suit uniquely designed to withstand extreme use and maximize performance.

Prime SP-16+, en colaboración con el Team McLaren F.1, es el mono racing homologado por la FIA más ligero que nunca. Prime Sp-16+ tiene un alma tecnológica sin igual en todo el mundo: realizada en los departamentos de I&D de Sparco, pesa tan solo 590 gramos (talla 52) y su calce no tiene precedentes. Son solo 2 las capas del Prime SP-16+ que ofrecen la máxima transpirabilidad. El proyecto ha sido llevado a cabo optimizando todo tipo de detalle: la cremallera es ultrafina, puños y tobillos son de Nomex/Viscosa sin costuras, se han reducido ulteriormente el cuello y las hombreras, el hilo de las costuras es todavía más fino y las costuras son todavía más planas. Prime SP-16+, un mono único, diseñado para un uso siempre más extremo y personalizado para llevar al límite las prestaciones.

RACING

SUITS

\* this picture is from the 2018 Formula 1 season

# PRIME

NEW



MANUFACTURER: SPARCO  
MODEL: R546-PRIME SP16-SPEC1  
HOM. NO: RS.281.16  
FIA STANDARD: 8856-2000

Homologation: FIA 8856-2000

Peso • Weight • Peso: 240/270 g/m<sup>2</sup>

Taglia • Size • Tamaño: 48-66

€ 1.390,00

**COMPOSIZIONE:** Meta-Aramide/Para-Aramide/Poliamide-immide. Assemblaggio 3 strati con un peso medio complessivo di 240/270 g/m<sup>2</sup>. Peso taglia 52: 740 g.

**CARATTERISTICHE:** la versione 2019 della tuta Prime SP-16 è stata completamente rivista ed ottimizzata nella sua costruzione, negli accessori e nel design, per ridurre ulteriormente il peso in favore di una sempre maggiore leggerezza e confort. Gli accessori sono stati alleggeriti del 25% rispetto alla precedente versione. La tuta Prime SP-16 è, ad oggi, una delle tute omologate FIA più leggere al mondo, concepita per soddisfare le necessità dei piloti più esigenti, che non scendono a compromessi in termini di prestazioni estreme.

**COMPOSITION:** Meta-Aramid / Para-aramid / Polyamide-imide. 3-layer sandwich with an average total weight of 240/270 g/m<sup>2</sup>. Weight Size 52: 740 g.

**FEATURES:** the 2019 version of the Prime SP-16 suit has been completely revised and optimised in its construction, accessories and design to further reduce weight for ever-greater lightness and comfort. Accessories are 25% lighter than for the previous version. The Prime SP-16 suit is currently one of the lightest FIA-homologated suits in the world, designed to satisfy the needs of the most demanding riders who won't compromise on extreme performance.

**COMPOSICIÓN:** Meta-Aramida/Para-Aramida/Poliamida-imida. Sándwich de 3 capas con un peso medio total de 240/270 g/m<sup>2</sup>. Peso Talla 52: 740 g.

**CARACTERÍSTICAS:** la versión 2019 del mono Prime SP-16 ofrece construcción, accesorios y diseño completamente re-considerados y optimizados, con vistas a reducir ulteriormente el peso para aumentar la liviandad y la comodidad. Los accesorios han sido aligerados un 25% respecto a la versión precedente. El mono Prime SP-16 es, hasta la fecha, uno de los monos homologados FIA más ligeros del mundo, diseñado para satisfacer las necesidades de los pilotos más exigentes, que no renuncian a nada cuando se trata de prestaciones extremas.



001133..B0

001133..NR

# SUPERSPEED

PREZZI IVA ESCLUSA  
VAT NOT INCLUDED - PRECIOS SIN IVA



MANUFACTURER: SPARCO  
MODEL: RS22 SUPERSPEED RS-9  
HOM. NO: RS.320.17  
FIA STANDARD: 8856-2000

Homologation: FIA 8856-2000

Homologation: SFI 3.2A/5

Peso • Weight • Peso: 290/320 g/m<sup>2</sup>

Taglia • Size • Tamaño: 48-66

€ 990,00

**COMPOSIZIONE:** tessuto multistrato doppia faccia seta/aramidico, sandwich tre strati con un peso medio complessivo di 290/320 g/m<sup>2</sup>.

**CARATTERISTICHE:** realizzata con un compound sottile, di peso medio leggero, nuovo tessuto esterno realizzato in parte di fibre naturali, di grande pregio come la seta anche in versione traforata per una migliore traspirazione. Insetti elasticizzati in tessuto Eagle (giro manica completo, fianchi, inserti gamba altezza ginocchio e schiena), maniche preformate. La tuta è arricchita di inserti in contrasto in tela ultraleggera e piatta. Trapuntatura con filo ultrasottile, maniglia di estrazione integrata nel giro manica; tasche a scomparsa, collo e cintura preformate.

**PERSONALIZZAZIONE:** stampa transfer ignifugi (consigliata) - ricami.

**COMPOSITION:** Double-faced silk/aramid multilayer fabric. Three-layer sandwich with an average weight of 290/320 g/m<sup>2</sup>.

**CHARACTERISTICS:** Made of a medium-light slim compound, but notably with a new outer fabric partly made of high-range natural fibres such as silk. The fabric is also used in a mesh version for better breathability. The suit has elastic panels made of Eagle fabric (complete armholes, sides, kneecap leg panels and back) and preformed sleeves. The suit is equipped with contrasting panels in flat ultralight cloth. Stitched quilting with thin yarn evokes the classic Sparco style. The suit includes integrated extraction epaulettes attached to the armholes, concealed pockets, preformed neck, and belt with the characteristic Sparco logo.

**PERSONALISATION:** fireproof transfer printing (recommended) - embroidery.

**COMPOSICIÓN:** tejido multicapa doble cara seda/aramida, sándwich de tres capas con un peso medio total de 290/390 g/m<sup>2</sup>.

**CARACTERÍSTICAS:** realizado con un compuesto fino y de peso medio-ligero y, en especial, con un nuevo tejido externo realizado en parte con fibras naturales preciadas como la seda. Elementos elasticizados en tejido Eagle (sisa completa, flancos, elementos en pierna a la altura de la rodilla y en la espalda), mangas preformadas. El mono incorpora elementos en contraste de tela ultraligera y plana, así como nuevos forros personalizados. Puntadas con hilo ultrafino, aleta de extracción incorporada en la sisa; bolsillos ojal, cuello y cintura preformados.

**PERSONALIZACIÓN:** estampado transfer ignífugo (aconsejado) - bordados



0011279.. RS

0011279.. AZ

0011279.. BI

0011279.. NR

# EAGLE



MANUFACTURER: SPARCO  
MODEL: RS40  
HOM. NO: 261.14  
FIA STANDARD: 8856-2000

Homologation: FIA 8856-2000

Peso • Weight • Peso: 290/320 g/m<sup>2</sup>

Taglia • Size • Tamaño: 48-66

€ 1.090,00



**COMPOSIZIONE:** NOME<sup>®</sup> antistatico Tes-  
suto HOCOTEX<sup>™</sup>. Sandwich monostrato  
con un peso medio di 290/320 g/m<sup>2</sup>.

**CARATTERISTICHE:** Vestibilità asciutta,  
maniche preformate, inserti elasticizza-  
ti. Struttura principale in Hocotex (tessuto  
monostrato-tessitura multistrato, ultra-  
sottile 0,6 mm), abbinato ad altri tessuti  
accessori, tra cui il tessuto elasticizzato  
Eagle, inserti in contrasto in tela ultrale-  
ggera e piatta di rinforzo antiabrasivo su  
gambe. Trapuntature realizzate con filo  
ultrasottile, tasche a scomparsa, collo e  
cintura. Estrattore ad aletta inserito a nel  
giro manica.

**PERSONALIZZAZIONE:** stampa transfer  
ignifugi (consigliata) - ricami.

**COMPOSITION:** NOME<sup>®</sup> antistatic HOCOTEX<sup>™</sup> fabric. Single layer sandwich with an average weight of 290/320 g/m<sup>2</sup>.

**CHARACTERISTICS:** The single layer Eagle RS-8.2 suit is made from a breathable, ultra-thin, multi-layer fabric (0.6 mm). It is made by pairing Hocotex fabric with other support fabrics including Eagle fabric for the panels at the back, sides and armpits. The Eagle fabric is a tried and tested material with better breathing and resistance properties than traditional jersey. Ultra-thin stitched quilting is used in classic style reinforced with anti-abrasion material on the legs and arms. The suit includes integrated extraction apauettes. The shoulders, which are compatible with the use of Hans devices, were designed to reduce pressure during races.

**PERSONALISATION:** fireproof transfer printing (recommended) - embroidery.

**COMPOSICIÓN:** NOME<sup>®</sup> antiestático Teji-  
do HOCOTEX<sup>™</sup>. Sándwich de una sola capa  
con un peso medio de 290/320 g/m<sup>2</sup>.

**CARACTERÍSTICAS:** vestibilidad más  
esbelta, mangas preformadas, elemen-  
tos elasticados. Estructura principal del  
mono en Hocotex (tejido de una sola ca-  
pa-textura multicapa, ultrafino 0,6 mm),  
combinado con otros tejidos accesorios,  
entre ellos el tejido elasticado, elemen-  
tos en contraste de tela ultraligera y plana  
de refuerzo antiabrasión en piernas y brazos.  
Puntadas realizadas con hilo ultrafino,  
bolsillos ojal, cuello y cintura. Extractor de  
aleta, introducido en la sisa.

**PERSONALIZACIÓN:** estampado transfer  
ignifugo (aconsejado) - bordados.



0011278H..BNRS

0011278H..BNAZ

0011278H..NGRS

0011278H..NGGR



# VICTORY



MANUFACTURER: SPARCO  
MODEL: R541  
HOM. NO: 267.15  
FIA STANDARD: 8856-2000

Homologation: FIA 8856-2000

Homologation: SFI 3.2A/5

Peso • Weight • Peso: 330/360 g/m<sup>2</sup>

Taglia • Size • Tamaño: 48-66

€ 790,00



**COMPOSIZIONE:** Meta-Aramidica, Tessuto HOCOTEX™, sandwich monostrato.  
**CARATTERISTICHE:** Progettata per garantire il massimo comfort al pilota durante la guida, con inserti elasticizzati in morbida maglia doppio frontura (giro manica completo e schiena), maniche preformate. Arricchita di inserti in contrasto in tela ultraleggera e piatta e nuove fodere personalizzate Sparco. Trapuntatura con filo ultrasottile, maniglia di estrazione, tasche a scomparsa, collo e cintura preformate.  
**PERSONALIZZAZIONE:** stampa transfer ignifughi (consigliata) - ricami.

**COMPOSITION:** Meta-Aramid HOCOTEX™ fabric, Single layer sandwich with an average weight of 330/360 gr/m<sup>2</sup>.  
**CHARACTERISTICS:** The suit was designed with the aim of ensuring maximum driver comfort while driving, with elasticised panels made of double-fronted soft mesh (armholes and back) and preformed sleeves. The suit is equipped with contrasting panels in flat ultralight cloth and new Sparco personalised linings, with some details in partial view, producing the characteristic Sparco style. Stitched quilting with ultra-thin yarn evokes the classic Sparco style, the suit has integrated extraction epaulettes made in the typical Sparco shoulder design, concealed pockets, preformed neck and belt with the characteristic Sparco logo.  
**PERSONALISATION:** fireproof transfer printing (recommended) - embroidery.

**COMPOSICIÓN:** Meta-Aramid, Tejido HOCOTEX™, sándwich de una sola capa.  
**CARACTERÍSTICAS:** El mono ha sido diseñado con vistas a garantizar la máxima comodidad al piloto mientras conduce, con elementos elasticizados de suave tricotado doble (sisa completa y espalda), mangas preformadas. El mono incorpora elementos en contraste de tela ultraligera y plana, así como nuevos forros personalizados Sparco. Las puntadas con hilo ultrafino, recuperan el estilo Sparco clásico: aleta de extracción conformada por la tradicional hombrera Sparco; bolsillos ojal, cuello y cintura preformados.  
**PERSONALIZACIÓN:** estampado transfer ignifugo (aconsejado) - bordados



0011277H..GRAR      0011277H.. GRAZ      0011277H.. NRGR      0011277H.. NRRS

# VINTAGE CLASSIC

NEW



**FIA APPROVED**

MANUFACTURER: SPARCO  
MODEL: R554  
HOM. NO: 341.18  
FIA STANDARD: 8856-2000

Homologation: FIA 8856-2000

Peso • Weight • Peso: 300/330 g/m<sup>2</sup>

Taglia • Size • Tamaño: 48-66

€ 590,00

**COMPOSIZIONE:** 95% Meta-Aramide/5% Para-Aramide. Assemblaggio 3 strati con un peso medio complessivo di 300/330 g/m<sup>2</sup>.  
Peso taglia 52: 1,10 kg.

**CARATTERISTICHE:** completamente rivista nel design e nella costruzione, la nuova tuta Vintage Classic ha una configurazione retrò ma al tempo stesso moderna; il design richiama lo stile heritage, con le classiche strisce rosse verticali, mentre le prestazioni sono da tuta moderna di alto livello con maniche preformate, cintura regolabile, trapuntature 10x10, tasche nascoste e taschino porta cellulare.

**COMPOSITION:** 95% Meta-Aramid/5% Para-Aramid. 3-layer sandwich with an average total weight of 300/330 g/m<sup>2</sup>.  
Weight Size 52: 1.10 kg.

**FEATURES:** completely revised in its design and construction, the new Vintage Classic suit has a retro yet simultaneously modern configuration; the design evokes a heritage style with its classic red vertical stripes, while the performance is that of a modern high-end suit with pre-shaped sleeves, adjustable belt, 10x10 quilts, hidden pockets and a mobile phone pocket.

**COMPOSICIÓN:** 95% Meta-Aramida/5% Para-Aramida. Sándwich de 3 capas con un peso medio total de 300/330 g/m<sup>2</sup>.  
Peso Talla 52: 1,10 kg.

**CARACTERÍSTICAS:** diseño y construcción completamente reconsiderados, el nuevo mono Vintage Classic ofrece una configuración retrò y al mismo tiempo moderna; el diseño evoca el estilo heritage, con las clásicas bandas rojas verticales, mientras que las prestaciones son las de un mono moderno de alto nivel, con mangas preformadas, cintura regulable, acolchados 10x10, bolsillos ocultos y bolsillo para móvil.



001128V..BIRS

# COMPETITION ⊕

NEW



MANUFACTURER: SPARCO  
MODEL: R554  
HOM. NO: 341.18  
FIA STANDARD: 8856-2000

Homologation: FIA 8856-2000

Peso • Weight • Peso: 300/330 g/m<sup>2</sup>

Taglia • Size • Tamaño: 48-66

€ 590,00

**COMPOSIZIONE:** 95% Meta-Aramide/5% Para-Aramide. Assemblaggio 3 strati con un peso medio complessivo di 300/330 g/m<sup>2</sup>. Peso taglia 52: 1,04 kg.

**CARATTERISTICHE:** la nuovissima tuta Competition presenta standard qualitativi e stilistici di ultima generazione. La configurazione include un tessuto esterno morbido e leggero, degli inserti traspiranti su fianchi e sottomanica, collo alleggerito, cuciture ultraleggere, maniche preformate, cintura regolabile e tasche nascoste. Il nuovo design pulito e lineare, senza trappuntature, dona slancio ed enfatizza la figura di chiunque indossi la tuta.

**COMPOSITION:** 95% Meta-Aramid / 5% Para-Aramid. 3-layer sandwich with an average total weight of 300/330 g/m<sup>2</sup>. Weight Size 52: 1.04 kg.

**FEATURES:** the brand new Competition suit offers latest-generation quality and style standards. Its configuration includes a soft and lightweight outer fabric, breathable inserts at the sides and under the arms, a lightweight collar, ultra-lightweight seams, pre-shaped sleeves, an adjustable belt and hidden pockets. The new clean and linear, non-quilted design gives dynamism and enhances the figure of anyone wearing the suit.

**COMPOSICIÓN:** 95% Meta-Aramida/5% Para-Aramida. Sándwich de 3 capas con un peso medio total de 300/330 g/m<sup>2</sup>. Peso Talla 52: 1,04 kg.

**CARACTERÍSTICAS:** el nuevísimo mono Competition ofrece niveles de calidad y estilo de última generación. La configuración incluye un tejido externo suave y ligero, insertos transpirables en flancos y axilas, cuello aligerado, costuras ultraligeras, mangas preformadas, cintura regulable y bolsillos ocultos. El nuevo diseño, limpio y lineal, sin acolchados, proporciona esbeltez y recalca la figura de quien lleva el mono.



001128..RSBN

001128..BMBI

001128..NRBR

001128..BINR

# COMPETITION LADY

NEW



 APPROVED

MANUFACTURER: SPARCO  
MODEL: R554  
HOM. NO: 341.18  
FIA STANDARD: 8856-2000

Homologation: FIA 8856-2000

Peso • Weight • Peso: 300/330 g/m<sup>2</sup>

Taglia • Size • Tamaño: 38-50

€ 590,00

**COMPOSIZIONE:** 95% Meta-Aramide/5% Para-Aramide. Assemblaggio 3 strati con un peso medio complessivo di 300/330 g/m<sup>2</sup>.  
Peso taglia 42: 880 g.

**CARATTERISTICHE:** la nuovissima tuta Competition presenta standard qualitativi e stilistici di ultima generazione. La configurazione include un tessuto esterno morbido e leggero, degli inserti traspiranti su fianchi e sottomanica, collo alleggerito, cuciture ultraleggere, maniche preformate, cintura regolabile e tasche nascoste. Il nuovo design pulito e lineare, senza trapuntature, dona slancio ed enfatizza la figura di chiunque indossi la tuta.

**COMPOSITION:** 95% Meta-Aramid/5% Para-Aramid. 3-layer sandwich with an average total weight of 300/330 g/m<sup>2</sup>.  
Weight Size 42: 880 g.

**FEATURES:** the brand new Competition suit offers latest-generation quality and style standards. Its configuration includes a soft and lightweight outer fabric, breathable inserts at the sides and under the arms, a lightweight collar, ultra-lightweight seams, pre-shaped sleeves, an adjustable belt and hidden pockets. The new clean and linear, non-quilted design gives dynamism and enhances the figure of anyone wearing the suit.

**COMPOSICIÓN:** 95% Meta-Aramida/5% Para-Aramida. Sándwich de 3 capas con un peso medio total de 300/330 g/m<sup>2</sup>.  
Peso Talla 42: 880 g.

**CARACTERÍSTICAS:** el nuevísimo mono Competition ofrece niveles de calidad y estilo de última generación. La configuración incluye un tejido externo suave y ligero, insertos transpirables en flancos y axilas, cuello aligerado, costuras ultraligeras, mangas preformadas, cintura regulable y bolsillos ocultos. El nuevo diseño, limpio y lineal, sin acolchados, proporciona esbeltez y recalca la figura de quien lleva el mono.



001128L..NRBF

# COMPETITION

NEW



MANUFACTURER: SPARCO  
MODEL: R538  
HOM. NO: 245.13  
FIA STANDARD: 8856-2000

Homologation: FIA 8856-2000

Peso • Weight • Peso: 340 g/m<sup>2</sup>

Taglia • Size • Tamaño: 46-66

€ 399,00

**COMPOSIZIONE:** 100% Meta aramide  
Assemblaggio tre strati con un peso medio complessivo di 340 g/m<sup>2</sup>  
Peso: taglia 52 = 1.17 KG

**CARATTERISTICHE:** la nuovissima tuta Competition presenta standard qualitativi e stilistici di ultima generazione. La configurazione include un tessuto esterno morbido e leggero, collo alleggerito, cuciture ultraleggere, maniche preformate, cintura regolabile e tasche nascoste. Il nuovo design pulito e lineare, senza trappuntature, dona slancio ed enfatizza la figura di chiunque indossi la tuta.

**COMPOSITION:** 100% Meta-Aramid. 3-layer sandwich with an average total weight of 340 g/m<sup>2</sup>.

Weight : Size 52 = 1.17 KG

**FEATURES:** the brand new Competition suit offers latest-generation quality and style standards. Its configuration includes a soft and lightweight outer fabric, a lightweight collar, ultra-lightweight seams, pre-shaped sleeves, an adjustable belt and hidden pockets. The new clean and linear, non-quilted design gives dynamism and enhances the figure of anyone wearing the suit.

**COMPOSICIÓN:** 100% Meta-Aramida. Sandwich de 3 capas con un peso medio total de 340 g/m<sup>2</sup>

Peso: Talla 52 = 1,17 kg

**CARACTERÍSTICAS:** el nuevísimo mono Competition ofrece niveles de calidad y estilo de última generación. La configuración incluye un tejido externo suave y ligero, cuello aligerado, costuras ultraligeras, mangas preformadas, cintura regulable y bolsillos ocultos. El nuevo diseño, limpio y lineal, sin acolchados, proporciona esbellez y recalca la figura de quien lleva el mono.



001134..BINR

001134..RSBI

001134..BMBI

001134..NRBI

# SPRINT

PREZZI IVA ESCLUSA  
VAT NOT INCLUDED • PRECIOS SIN IVA



MANUFACTURER: SPARCO  
MODEL: R548-SPRINT RS-2.1  
HOM. NO: RS.287.16  
FIA STANDARD: 8856-2000

Homologation: FIA 8856-2000 - C E

Homologation: SFI 3.2A/5

Peso • Weight • Peso: 360/390 g/m<sup>2</sup>

Taglia • Size • Tamaño: 48-66

€ 344,00

La Sprint RS-2.1 è la tuta entry level per eccellenza. Evoluta nei dettagli e nella qualità dei materiali ai massimi livelli. La tuta è facilmente personalizzabile anche a mezzo stampe.

**COMPOSIZIONE:** Meta Aramidico. Sandwich due strati con un peso medio di 360/390 g/m<sup>2</sup>.

**CARATTERISTICHE:** La tuta Sprint RS-2.1 è una tuta due strati, realizzata con tessuti e fodere di nuova generazione e con un ottimo rapporto qualità/prezzo. Giromanica e pannello schiena in maglia elastica. Tasche jeans, maniche preformate e maglieria alleggerita, la stessa usata per le tute di medio/alto gamma

The Sprint RS-2.1 is an excellent entry level suit. Improved details and top quality materials. The suit can be easily personalised including the use of prints and features mesh panels at the armpits and back.

**COMPOSITION:** Meta Aramid. Two-layer sandwich with an average weight of 360/390 g/m<sup>2</sup>.

**CHARACTERISTICS:** The Sprint RS-2.1 suit has two layers made of new generation fabric and offers excellent value for its cost. Suit includes elastic armpits and back panel for increased driver comfort. Jean type pockets, preformed sleeves and light fabric which has the same materials as used for all the top/medium range suits.

El Sprint RS-2.1 es el mono básico por excelencia. Evolucionado en cuanto a detalles y calidad de los materiales hasta los máximos niveles. El mono se puede personalizar fácilmente también mediante estampados y se realiza con insertos de jersey en sisa y espalda.

**COMPOSICIÓN:** Meta Aramidico. Sandwich de dos capas con un peso medio de 360/390 g/m<sup>2</sup>.

**CARACTERÍSTICAS:** Mono de dos capas, realizado con tejidos y forros de nueva generación y que ofrece una excelente relación calidad/precio. Sisa y panel de espalda de jersey fino elástico para aumentar su confort. Bolsillos de jeans, mangas preformadas y punto aligerado, el mismo utilizado para los monos de gama medio/alta.



001091..NRBI

001091..NRRS

001091..RS

001091..AZ

001091..NR

# CONQUEST

PREZZI IVA ESCLUSA  
VAT NOT INCLUDED - PRECIOS SIN IVA



MANUFACTURER: SPARCO  
MODEL: R506  
HOM. NO: RS.006.01  
FIA STANDARD: 8856-2000

Homologation: FIA 8856-2000

Homologation: SFI 3.2A/5

Peso • Weight • Peso: 400 g/m<sup>2</sup>

Taglia • Size • Tamaño: 48-60

€ 265,00

Sparco reintroduce nel suo catalogo una tuta Racing omologata, con il miglior rapporto qualità/prezzo. Tuta realizzata in due strati, spallina/estrattore classico a T e fodera cintura in contrasto, per un look moderno. Tasche inserite, maniche preformate, trapuntature classiche ed accessori di ultima generazione.

Sparco is proud to announce the Racing Suit Conquest-R506, a 2 layer suit with its classic "T" shoulder/puller in red or in white colour. This suit has two pockets while the sleeves are preformed with classic "square" quilting.

Sparco reintroduce en su catálogo un mono Racing homologado/aprobado, con la mejor relación calidad/precio. Un mono realizado en dos capas, con inserto de hombreras ojal /extractor clásico a "T" y forro de la cintura en contraste, para un look moderno. Bolsillos incluidos, mangas preformadas, puntadas clásicas y accesorios de última generación.



0011282..NRBI

0011282..AZBI

# ONE

NEW



Homologation: SFI 3.2A/1

Peso • Weight • Peso: 170 g/m<sup>2</sup>

Taglia • Size • Tamaño: XS-XXL

€ 155,00



**COMPOSIZIONE:** Meta-Aramide/Modacrilico. Assemblaggio monostrato con un peso medio complessivo di 170 g/m<sup>2</sup>.  
Peso taglia 52: 620 g.

**CARATTERISTICHE:** completamente rivista nel design e nella costruzione, la nuova tuta One è più leggera e confortevole della precedente. Maniche preformate, zip doppio cursore, tasche nascoste, cintura regolabile e flap delle caviglie regolabile ne fanno un'ottima tuta per piloti di gare nazionali o storiche, meccanici, tecnici o commissari di gara.

**COMPOSITION:** Meta-Aramid/Modacrylic. Single-layer construction with an average total weight of 170 g/m<sup>2</sup>.

Weight Size 52: 620 g.

**FEATURES:** completely revised in its design and construction, the new One suit is lighter and more comfortable than the previous version. Preformed sleeves, a double slider zip, hidden pockets, an adjustable belt and adjustable ankle flaps make it an outstanding suit for drivers in national-level or historic races, mechanics, technicians or race officials.

**COMPOSICIÓN:** Meta-Aramida/Modacrílica. Montaje de una sola capa con un peso medio total de 170 g/m<sup>2</sup>.

Peso Talla 52: 620 g.

**CARACTERÍSTICAS:** con diseño y construcción completamente reconsiderados, el nuevo mono One es más ligero y cómodo que el precedente. Mangas preformadas, cremallera de doble cursor, bolsillos ocultos, cintura regulable y flap de los tobillos regulable hacen que sea un mono excelente para pilotos de competiciones nacionales o históricas, mecánicos, técnicos o comisarios de carrera.

001058NR..



RACING

# UNDERWEAR



\* this picture is from the 2018 Formula 1 season

ISI<sup>®</sup>

# SHIELD RW-9

Homologation: FIA 8856-2000

Homologation: SFI 3.3

Underwear di ultima generazione (Jersey in Aramidico, Modacrilico, Modal Visco-se, Elastane) che si adatta al corpo per un comfort mai provato. Nuovo filato costruito per eliminare velocemente il sudore dalla pelle per la massima traspirabilità e freschezza. Sheild RW-9 è un seamless con alcune parti smacchinate (schiena, sotto le ascelle e petto) per la massima traspirabilità. Massima leggerezza: solamente 180 g/m<sup>2</sup>. RW-9 è l'underwear ignifugo più leggero al mondo. Trattato X-Cool Silver, garantisce benessere e freschezza.

Revolutionary Underwear designed to conform to body shape with technical material (Aramid Jersey, Acrilate, viscosa Modal, Spandex) in order to obtain incredible comfort while driving. New fiber has been designed and constructed to remove sweat as quickly as possible, for added breathability and freshness. Sheild RW-9 is seamless with added breathability to the back, armpit, and chest areas. SPARCO underwear weights only 180 g/m<sup>2</sup>, most lightweight fireproof underwear in the world. Shield RW-9 also contains X-Cool fibers which guarantee comfort and freshness.

Ropa interior de última generación construido adaptando el material (Jersey en Aramid, Modacrilico, viscosa Modal, Spandex) al cuerpo para tener el máximo confort nunca antes experimentada en la conducción. El nuevo hilo ha sido construido y diseñado para eliminar lo más rápidamente posible el sudor de la piel, garantizando una máxima traspirabilidad y frescura para el piloto. La construcción de la Sheild RW-9 es sin costuras (espalda, debajo de los brazos y el pecho) para asegurar la máxima traspirabilidad posible. La calidad del hilo se combina con la máxima ligereza: nuestra ropa interior pesa sólo 180 g/m<sup>2</sup>, entonces es la ropa interior ignifuga la mas ligera en el mundo. El nuevo Shield RW-9 lleva también el principio X Cool: garantía de frescura y bienestar en el mismo tiempo.



La ricarica X-Cool permette il prolungamento del trattamento rinfrescante sulla tuta e sull'underwear (maglia, pantalone e calze). L'applicazione può essere effettuata con un semplice lavaggio in lavatrice. Simply add to your washing machine before washing overalls or underwear and the original X-Cool treatment is recharged. Treats one racersuit or 1 set of underwear (pant, top and socks). La recarga de X-Cool permite la extensión del tratamiento rinfrescante en el mono y en la ropa interior (camiseta, pantalón y calcetines). La aplicación puede realizarse con un simple lavado en la lavadora.

€ 29,00

001157RECHARGE



FIA APPROVED

MANUFACTURER: SPARCO  
MODEL: RW9  
FIA STANDARD: 8856-2000

FIA APPROVED

MANUFACTURER: SPARCO  
MODEL: RW9  
FIA STANDARD: 8856-2000

Size: XS/S - M/L - XL/XXL - XXXL

€ 122,00 € 119,00

001764MBO.. 001764MNR..

Size: XS/S - M/L - XL/XXL - XXXL

€ 95,00 € 95,00

001765PBO.. 001765PNR..



FIA APPROVED

MANUFACTURER: SPARCO  
MODEL: RW9  
FIA STANDARD: 8856-2000

Size: XS/S - M/L - XL/XXL - XXXL

€ 53,00 € 49,00

001494BO.. 001494NR..



Size: XS/S - M/L - XL/XXL - XXXL

€ 106,00 € 99,00

001795BO.. 001795NR..

## Compression

COMPOSIZIONE: 10% Meta-aramidico. 84% Viscose. 6% Elastan.

CARATTERISTICHE: Derivata dalle calze a compressione graduata di uso sportivo, utilizzano il medesimo principio della terapia compressiva e possiedono una caratteristica particolare: esercitare una pressione massima alla caviglia che di-

minuisce man mano che si sale verso la coscia, in modo da favorire la risalita del sangue verso l'alto. Le calze COMPRESSION Sparco hanno un potere compressivo di classe 1 (> 21 mmHg) e sono efficaci nel prevenire lo sviluppo di problemi circolatori ed estremamente efficaci ad attenuare la sensazione di pesantezza e di affaticamento alle gambe.

COMPOSITION: 10% Meta-aramid. 84% Viscose. 6% Elastan.

CHARACTERISTICS: Derived from the new graduated compression socks commonly used for sports, these use the same principles as compression therapy with a particular characteristic: exerting maximum pressure at the ankle that decreases as it goes up the leg facilitating bloodflow upwards. Sparco COMPRESSION socks have a class 1 (> 21 mmHg) compression force and are effective in preventing the development of circulatory problems and extremely effective in alleviating the feeling of heaviness and fatigue in the legs.

COMPOSICIÓN: 10% meta aramida. 84% modal. 6% elastano.

CARACTERÍSTICAS: Derivados de los calcetines elásticos de compresión graduada para uso deportivo, utilizan el mismo principio de la terapia compresiva y tienen una característica especial: ejercen una presión máxima en los tobillos, que se reduce a medida que se sube hacia los muslos, para favorecer la circulación de la sangre hacia arriba.



FIA APPROVED

MANUFACTURER: SPARCO  
MODEL: COMPRESSION  
FIA STANDARD: 8856-2000

Size: 38/39 - 40/41 - 42/43 - 44/45 - 46

€ 53,00 € 53,00

001512BI.. 001512NR..



FIA APPROVED

MANUFACTURER: SPARCO  
MODEL: 001510ICE  
FIA STANDARD: 8856-2000

Size: 38/39 - 46

€ 35,00 € 35,00

001510ICE.. 001510ICENR..

# DELTA RW-6

## Homologation: FIA 8856-2000

La nuova maglieria Delta RW-6 è realizzata in un misto fibre estremamente confortevoli e morbide attraverso una smacchinatura definita "body-size" dove il capo è prodotto in unica soluzione eliminando le cuciture laterali. Questo tipo di lavorazione permette di creare diverse aree più o meno elasticizzate a seconda delle necessità. La presenza di zone più elastiche agevola la vestibilità del capo.

**COMPOSIZIONE:** 50% Cotone Flame Retardant - 50% Modacrilico FR. Tessuto con un peso medio di 190/200 g/m<sup>2</sup>.

The new Delta RW-6 fabric is made from a mixture of very comfortable, soft fibres by means of a processing method known as "body-size" in which the garment is produced as a single piece item with no stitching at the sides. This type of process means different sections can be made more or less elastic to meet differing needs. The existence of more elastic sections makes the garment more comfortable to wear.

**COMPOSITION:** 50% Flame Retardant Cotton - 50% Modacrylic Fibres. Average weight of fabric 190/200 g/m<sup>2</sup>.

Los nuevos géneros de punto Delta RW-6 se realizan con una combinación de fibras sumamente cómodas y suaves mediante una elaboración denominada "body-size", que permite fabricar la prenda de una sola vez sin costuras laterales. Este tipo de elaboración permite crear diferentes áreas más o menos elásticas según las necesidades. La presencia de zonas más elásticas facilita el calce de la prenda.

**COMPOSICIÓN:** 50% Algodón retardador de llama - 50% Modacrilico FR. Tejido con un peso medio de 190/200 g/m<sup>2</sup>.



MANUFACTURER: SPARCO  
MODEL: TOP DELTA RW-6  
FIA STANDARD: 8856-2000

Size: XS/S - M/L - XL/XXL

€ 83,00

001770MBI..



MANUFACTURER: SPARCO  
MODEL: BOTTOM DELTA RW-6  
FIA STANDARD: 8856-2000

Size: XS/S - M/L - XL/XXL

€ 72,00

001771PBI..

Struttura della maglia differenziata per ottenere un maggiore confort ed incrementare la traspirabilità in alcune zone specifiche. Collo elasticizzato in costa. La manica raglan conferisce al capo una vestibilità più confortevole grazie al posizionamento delle cuciture delle maniche in zone meno soggette a pressioni e schiacciamenti. Polsini e fondo maglia rifinite più sottili per un maggiore confort.

Different mesh structure to provide better comfort and enhance breathability in different specific areas. Elastic ribbed neck band. The raglan sleeve pattern makes the garment more comfortable thanks to the stitching of the sleeves which is positioned in an area that is subjected to less pressure. The wrists and waist have finer stitching for increased comfort.

Estructura del punto diferente para obtener un mayor confort e incrementar la transpirabilidad en algunas zonas específicas. Cuello elasticizado acanalado. La manga raglán ofrece a la prenda un calce más cómodo gracias a que las costuras de las mangas están en zonas meno sujetas a presiones y aplastamientos. Puños y fondo acabados más finos para un mayor confort.

Doppia struttura differenziata tra la parte anteriore e quella posteriore del sottocasco. Apertura occhi rifinita con bordo maglia per una maggiore resistenza all'usura. Two different structure between the front and rear of the balaclava. Soft eye holes with mesh edges for improved resistance to wear and tear. Doble estructura diferente entre la parte delantera y la trasera del sotocasco. Abertura para los ojos acabada con borde de punto para una mayor resistencia al desgaste.



MANUFACTURER: SPARCO  
MODEL: BALACLAVA DELTA RW-6  
FIA STANDARD: 8856-2000

Single size

€ 37,00

001483BI



MANUFACTURER: SPARCO  
MODEL: BALACLAVA DELTA RW-6  
FIA STANDARD: 8856-2000

Single size

€ 37,00

001484BI

Struttura del pantalone differenziata per ottenere un maggiore confort ed incrementare la traspirabilità in alcune zone specifiche. Bordo punto vita elastico immagliato in struttura a costa. Caviglie rifinite più sottili per un maggiore confort.

Different structure of the pants to provide better comfort and enhance breathability in different specific areas. Elastic, ribbed, mesh waist band edges. The ankles have finer stitching for increased comfort.

Estructura del pantalón diferente para obtener un mayor confort e incrementar la transpirabilidad en algunas zonas específicas. Borde de la cintura elástico realizado con punto en estructura acanalada. Tobillos acabados más finos para un mayor confort.



MANUFACTURER: SPARCO  
MODEL: 001521  
FIA STANDARD: 8856-2000

Size: 38/39 - 46

€ 24,50

001521..



MANUFACTURER: SPARCO  
MODEL: 001511  
FIA STANDARD: 8856-2000

Size: 38/39 - 46

€ 16,50

001511..

# GUARD RW-3

Homologation: FIA 8856-2000

Homologation: SFI 3.3

Sparco reintroduce nel suo catalogo il miglior underwear entry level sul mercato; un compromesso classico di tagli e qualità con un materiale 100% meta-aramidico, ammorbidito soft-touch. Maniche raglan, fianchi preformati con collo alto rinsertato sul retro, regular fit.

GUARD RW-3 is the entry level underwear range that combines great comfort at a competitive price.

Balaclava with two different structure between the front and the rear of the Balaclava, 100% Meta-aramid with soft-touch application system

Top shirt has a regular fitting with raglan sleeves to obtain the maximum comfort on a driving position, 100% Meta-aramid with soft-touch application system

Bottom has a regular fitting, 100% Meta-aramid with soft-touch application system.

Sparco reintroduce en su catálogo la mejor ropa interior de nivel básico del mercado; un compromiso clásico de cortes y calidad con un 100% de meta-aramida, material suave dal tocco suave-(soft touch). Mangas raglan, lados preformados con cuello alto en la parte posterior, ajuste regular.



 APPROVED

MANUFACTURER: SPARCO  
MODEL: RW3  
FIA STANDARD: 8856-2000

Size: S - M - L - XL - XXL

€ 65,00

001772M



 APPROVED

MANUFACTURER: SPARCO  
MODEL: RW3  
FIA STANDARD: 8856-2000

Size: S - M - L - XL - XXL

€ 55,90

001772P



 APPROVED

MANUFACTURER: SPARCO  
MODEL: RW3  
FIA STANDARD: 8856-2000

Single size

€ 33,00

001486B1



UNDERWEAR

85

RACING

84

PREZZI IVA ESCLUSA  
VAT NOT INCLUDED - PRECIOS SIN IVA

# NOT FIA APPROVED

T-shirt a collo basso e mezza manica specifica per tutti i campionati dove non siano obbligatorie le omologazioni FIA / SFI. Struttura della maglia differenziata per ottenere un maggiore confort ed incrementare la traspirabilità in alcune zone specifiche. Collo elasticizzato in costa e ribassato. La manica raglan conferisce al capo una vestibilità più confortevole grazie al posizionamento delle cuciture delle maniche in zone meno soggette a pressioni e schiacciamenti. Polsini e fondo maglia rifinite più sottili per un maggiore confort.

Low neck, short sleeve T-shirt specifically for all championships in which FIA/SFI type approved garments are not mandatory. Differentiated mesh structure to provide better comfort and enhance breathability in different specific areas. Elastic low ribbed neck band. The raglan sleeve pattern makes the garment more comfortable thanks to the stitching of the sleeves which is positioned in an area that is subjected to less pressure. The wrists and waist have finer stitching for increased comfort.

Camiseta de cuello bajo y manga corta, específica para todos los campeonatos que no exijan las homologaciones FIA / SFI. Estructura del punto diferente para obtener un mayor confort e incrementar la transpirabilidad en algunas zonas específicas. Cuello elasticizado acanalado y bajo. La manga raglán ofrece a la prenda un calce más cómodo gracias a que las costuras de las mangas están en zonas menos sujetas a presiones y aplastamientos. Puños y fondo acabados más finos para un mayor confort.



Size: XS/S - M/L - XL/XXL

€ 60,00

001796TBI..

Bermuda specifica per tutti i campionati dove non siano obbligatorie le omologazioni FIA / SFI. Struttura del bermuda differenziata per ottenere un maggiore confort ed incrementare la traspirabilità in alcune zone specifiche. Bordo punto vita elastico immagliato in struttura a costa.

Bermuda shorts specifically for all championships in which FIA/SFI type approved garments are not mandatory. Differentiated mesh structure of the shorts to provide better comfort and enhance breathability in certain specific areas. Elastic, ribbed, mesh waist band edges.

Bermudas específicas para todos los campeonatos que no exijan las homologaciones FIA / SFI. Estructura de las bermudas diferente para obtener un mayor confort e incrementar la transpirabilidad en algunas zonas específicas. Borde de la cintura elástico realizado con punto en estructura acanalada.



Size: XS/S - M/L - XL/XXL

€ 50,00

001710BBI..

Sottocasco monostrato specifico per tutti i campionati dove non siano obbligatorie le omologazioni FIA / SFI. Doppia struttura differenziata tra la parte anteriore e quella posteriore. Apertura occhi rifinita con bordo maglia per una maggiore resistenza all'usura.

Single layer balaclava specifically for all championships in which FIA/SFI type approved garments are not mandatory. Double differentiated structure between the front and rear of the balaclava. Soft eye holes with mesh edges for improved resistance to wear and tear.

Sotocasco de una sola capa, específico para todos los campeonatos que no exijan las homologaciones FIA / SFI. Doble estructura diferente entre la parte delantera y la trasera. Apertura para los ojos acabada con borde de punto para una mayor resistencia al desgaste.



Single size

€ 27,50

001485BI..

## GINOCCHIERE KNEE PADS RODILLERAS



€ 65,00

00156N

## GOMITIERE ELBOW PADS CODERAS



€ 50,00

00157N

## CINTURA CONTENIMENTO BRACCIA ARM RESTRAINTS CINTURÓN DE RETENCIÓN DE LOS BRAZOS

Sistema di contenimento delle braccia consigliato su vetture aperte tipo Dragster, Midget e Fuoristrada. Omologato SFI 3.3.

Arm restraints suggested for Dragster, Midget and Off Road racing. SFI 3.3 approved.

Sistema de retención de los brazos aconsejado en los coches abiertos como Dragster, Midget y Off-Roads. Homologado SFI 3.3.

€ 29,00



00158SETRS

00158SETAZ

00158SETNR

RACING

# SHOES



S<sup>®</sup>



MANUFACTURER: SPARCO  
MODEL: PRIME RB-11 +  
FIA STANDARD: 8856-2000

Homologation: FIA 8856-2000

Peso • Weight • Peso: 170 g (size 41)

Taglia • Size • Tamaño: 38-48

€ ON DEMAND

ON DEMAND

PRIME ⊕

Sviluppate in collaborazione con il Team McLaren F1, le Prime Rb-11+ sono le scarpe in pelle omologate più leggere al mondo. La tomaia è realizzata in singolo pezzo in pelle di canguro, traforata internamente ed esternamente, per ottenere il miglior rapporto tra peso, comfort e flessibilità. La chiusura avviene tramite uno strap ergonomico ed ultraleggero mentre la linguetta è in tessuto stampabile per ottenere una calzatura ottimale ed un ottimo grado di personalizzazione. La fodera interna è in materiale fresco e traspirante. La suola è in gomma ultrasottile per avere la massima sensibilità e grip sui pedali. Le scarpe Prime RB-11 + sono interamente personalizzabili per mezzo di stampa inkjet.

Developed in collaboration with the McLaren F1 Team, the Prime Rb-11+ are the lightest approved leather shoes in the world. The uppers are made of a single piece in kangaroo leather, perforated inside and outside, to achieve the best balance between weight, comfort and flexibility. Closure is via an ergonomic and ultralight strap while the tongue is in printable fabric to obtain an optimal fit and an excellent degree of customization. The inner lining is made of fresh and breathable material. The sole is made of ultra-thin rubber for maximum sensitivity and grip on the pedals. The Prime RB-11 + shoes are fully customisable by means of inkjet printing.

Desarrollados en colaboración con el Team McLaren F1, los Prime Rb-11+ son los zapatos de piel homologados más ligeros del mundo. El empeine es de una sola pieza en piel de canguro, calado interna y externamente para ofrecer la mejor relación entre peso, comodidad y flexibilidad. El cierre es mediante tira ergonómica y ultraligera, mientras que la lengüeta es de tejido imprimible para obtener un calzado óptimo y un excelente grado de personalización. El forro interior es de un material fresco y transpirable. La suela es de goma ultrafina para tener la máxima sensibilidad y agarre sobre los pedales. Los zapatos Prime RB-11 + son completamente personalizable por medio de impresión de chorro de tinta.



# SUPERLEGGERA RB-10.1



MANUFACTURER: SPARCO  
MODEL: SUPERLEGGERA RB-10.1  
FIA STANDARD: 8856-2000

Homologation: FIA 8856-2000

Taglia • Size • Tamaño: 38-48

€ 395,00



Tessuto ignifugo stampabile e personalizzabile. Gli inserti sono in pelle di canguro leggero, estremamente più resistente di una normale pelle. La suola è ultraleggera e si adatta perfettamente ad ogni tipo di tallone. Rinforzo laterale integrato. La linguetta in tessuto stretch avvolge il piede come una seconda pelle impedendo l'ingresso di polvere, terra o altro materiale nella scarpa. Inserto elasticizzato posteriore, posizionato sopra al tallone, per migliorare la calzata e il fitting ed agevolare il movimento della cavaglia durante la guida.

Peso: taglia 42 (paio) = 230 g

Superleggera RB-10.1 race boots are made with a fire retardant fabric and can be personalised including the use of prints. The panels are made from lightweight kangaroo skin which is much more resistant than normal leather. The ultra-light soles conform perfectly to any heel. Integrated lateral reinforcement. The stretch fabric tongue wraps around the foot like a second skin and prevents dust, soil or other materials from entering the shoe. Superleggera RB-10.1 racing boots have an elastic panel at the rear just above the heel to improve fit and allow the ankle to move freely when driving.

Weight : Size 42 (pair) = 230 g

Tejido ignifugo estampable y personalizable. Los insertos son de piel de canguro ligero, mucho más resistente que una piel normal. La suela es ultraligera y se adapta perfectamente a cada tipo de talón. Refuerzo lateral incorporado. La lengüeta es de tejido stretch y envuelve el pie como una segunda piel, impidiendo que entre polvo, tierra u otro material en el zapato. Inserto elasticizado trasero, situado encima del talón, para mejorar el ajuste y facilitar el movimiento del tobillo mientras se conduce.

Peso: Talla 42 (par) = 230 g



001237..NR

# FORMULA RB-8.1



MANUFACTURER: SPARCO  
MODEL: RB-8.1  
FIA STANDARD: 8856-2000

Homologation: FIA 8856-2000

Homologation: SFI 3.3/5

Taglia • Size • Tamaño: 37-48

€ 199,00



## CARATTERISTICHE:

Strap regolabile sulla caviglia. Sistema di allacciatura rapido e ultraleggero. Nuova pelle traforata con finitura opaca e mano morbida per un feeling più avvolgente: il piede è agevolato nel movimento e la pelle si adatta alla sua forma. Il tessuto posteriore elasticizzato aiuta il movimento della caviglia. Fodera in tessuto Cotone-Modacrilico accoppiata con espanso PU ultratraspirante. Inserti in pelle di rinforzo laterali per diminuire l'impatto. Suola in pura gomma ultrasottile, antistatica e con texture per avere il migliore grip sul pedale.

## PERSONALIZZAZIONE:

stampa transfer - ricami.

## CHARACTERISTICS:

Adjustable strap on the ankle. Logos printed directly on the leather. Ventilated leather for breathability. Rapid and ultralight lacing system. New leather with soft-hand matte finish, secure wraparound feel: the foot is facilitated in its movements and the leather adapts to its shape. The elastic rear fabric aids the movements of the ankle. Lining in Cotton-Modacrylic fabric coupled with ultra-breathable expanded PU. Leather reinforcement side-panels to reduce impacts. Ultrathin pure rubber sole, antistatic and with a special texture for better pedal grip.

## PERSONALISATION:

transfer printing - embroidery.

## CARACTERÍSTICAS:

Tira regulable en el tobillo. Sistema de abrochado rápido y ultraligero. Nueva piel calada con acabado mate y toque suave, para una sensación más envolvente: el pie tiene más comodidad de movimiento y la piel se adapta a su forma. El tejido trasero elasticizado facilita el movimiento del tobillo. Forro de tejido Algodón-Modacrilico acoplado con PU expandido ultratranspirable. Elementos laterales de refuerzo en Piel para disminuir el impacto. Suola de pura goma ultrafina, antiestática y con textura para tener el mejor agarre sobre el pedal.

## PERSONALIZACIÓN:

estampado transfer - bordados.



001251..NRAF (NO SFI)



001251..NRGF (NO SFI)



001251..AZBI



001251..BINR



001251..NRBI



001251..RSBI



# APEX RB-7



MANUFACTURER: SPARCO  
MODEL: RB-7  
FIA STANDARD: 8856-2000

Homologation: FIA 8856-2000

Taglia • Size • Tamaño: 37-48

€ 165,00



## CARATTERISTICHE:

Strap regolabile sulla caviglia. Area con Pelle traforata per traspirazione. Sistema di allacciatura rapido e ultraleggero. Pelle con finitura opaca e mano morbida per un feeling più avvolgente: il piede è agevolato nel movimento e la pelle si adatta alla sua forma. Pelle gommata per rinforzi e contro abrasione. Il tessuto posteriore elasticizzato aiuta il movimento della caviglia. Fodera in tessuto leggero, avvolgente e ultratraspirante. Suola in pura gomma ultrasottile, antistatica e con texture per avere il migliore grip sul pedale.

**PERSONALIZZAZIONE:**  
stampa transfer - ricami.

## CHARACTERISTICS:

Adjustable strap on the ankle. Area with ventilated leather for breathability. Rapid and ultralight lacing system with double tie option, either on the tongue or inside a special concealed compartment. Two types of leather, one with a soft-hand matte finish and a secure wraparound feel: the foot is facilitated in its movements and the leather adapts to its shape. The shoe also includes rubber leather for reinforcement and anti-abrasion. The elastic rear fabric aids the movements of the ankle. Lining in light fabric, wraparound and ultra-breathable. Ultrathin pure rubber sole, antistatic and with a special texture for better pedal grip.

**PERSONALISATION:**  
transfer printing - embroidery.

## CARACTERÍSTICAS:

Tira regulable en el tobillo. Zona con Piel calada para transpirabilidad. Sistema de abrochado rápido y ultraligero. Piel con acabado mate y toque suave, para una sensación más envolvente: el pie tiene más comodidad de movimiento y la piel se adapta a su forma. Piel engomada para refuerzos y contra la abrasión. El tejido trasero elasticizado facilita el movimiento del tobillo. Forro de tejido ligero, envolvente y ultratranspirable. Suela de pura goma ultrafina, antiestática y con textura para tener el mejor agarre sobre el pedal.

**PERSONALIZACIÓN:**  
estampado transfer - bordados.



001261..AZGR



001261..BIRS



001261..NRBI



001261..NRGI

# SLALOM RB-3.1

NEW



MANUFACTURER: SPARCO  
MODEL: SLALOM RB-3  
FIA STANDARD: 8856-2000

Homologation: FIA 8856-2000

Homologation: SFI 3.3/5

Taglia • Size • Tamaño: 36-48

€ 109,00



Stivaletti Racing in pelle scamosciata. Possibilità di personalizzazione secondo guideline Sparco.

**COMPOSIZIONE:** Tomaia in pelle scamosciata. Soletta interna in cuoio. Suola in gomma naturale.

Suede racing boots. Possibility of customisation following Sparco guidelines.

**COMPOSITION:** Suede exterior. Leather insole. Natural rubber sole.

Botas Racing en piel de ante. Posibilidad de personalización según las directrices Sparco.

**COMPOSICIÓN:** Parte superior en piel de ante. Plantilla en cuero. Suela en caucho natural.



001264..AZ



001264..RS



001264..NR

# SLALOM CLASSIC



MANUFACTURER: SPARCO  
MODEL: SLALOM RB-3  
FIA STANDARD: 8856-2000

Homologation: FIA 8856-2000

Taglia • Size • Tamaño: 36-48

€ 135,00



Stivaletto realizzato in pelle di vitello con possibilità di personalizzazione secondo le linee guida Sparco.

**COMPOSIZIONE:** la tomaia dello stivaletto Slalom RB-3 è costruita in pelle di vitello di altissima qualità e trattata per conferire morbidezza. La soletta interna è in cuoio mentre la suola è in gomma naturale.

Classic RB-3 racing boots are made from calf leather and can be personalised following Sparco guidelines.

**COMPOSIZIONE:** the exterior of Slalom RB-3 boots is made of very high quality calf skin leather which has been softened. The insoles are made from leather and the soles are natural rubber.

El botín de racing Slalom Classic se realiza con piel de becerro con la posibilidad de personalización con arreglo a las pautas Sparco.

**COMPOSICIÓN:** la pala del botón Slalom RB-3 es de piel de becerro de altísima calidad y tratada para ofrecer suavidad. La plantilla interna es de cuero mientras que la suela es de goma natural.

# RALLY OVERSHOES



Sovrascarpe in gomma naturale ideali per proteggere la suola delle scarpe sui fondi bagnati o abrasivi. Utilizzo Rally.

Overshoes in natural rubber, ideal for protecting shoe soles on wet or abrasive surfaces. Rally use.

Sobretotas en caucho natural, ideales para proteger la suela del calzado sobre superficies mojadas o abrasivas. Uso en Rally.

Taglia • Size • Tamaño: S-XL

S (38.5-40), M (40-41.5), L (41.5-43), XL (43.5-45)

€ 35,00

002431..N



001239..MA



001239..NR

RACING

# GLOVES



# TIDE RG-9



MANUFACTURER: SPARCO  
MODEL: TIDE  
FIA STANDARD: 8856-2000

Homologation: FIA 8856-2000

Homologation: SFI 3.3/5

Taglia • Size • Tamaño: 8-13

€ 185,00

Guanti con cuciture esterne con palmo preformato ergonomico ad alto grip e shock absorber. Possibilità di personalizzazione secondo guideline Sparco.

**COMPOSIZIONE:** Maglina 100% meta-aramidica. Palmo con rinforzi in HTX 3D "Vulcano" (brevetto Sparco). Dorso con rinforzi in HTX 3D.

Gloves with external seams and preformed, high-grip, shock-absorbant, ergonomic palms. Possibility of customisation following Sparco guidelines.

**COMPOSIZIONE:** 100% meta-aramid jersey. Palm with 3D "Vulcano" HTX reinforcements (Sparco patent). Back with 3D HTX reinforcements.

Guantes con costuras exteriores, con palma preformada ergonómica, de gran agarre y absorción de impactos. Posibilidad de personalización según las directrices Sparco.

**COMPOSICIÓN:** Tejido de punto 100% meta-aramida. Palma con refuerzos en HTX 3D "Vulcano" (patente Sparco). Dorso con refuerzos en HTX 3D.



001355..RS



001355..AZ



001355..NR



001355..BI

# ARROW RG-7evo



MANUFACTURER: SPARCO  
MODEL: RG-7  
FIA STANDARD: 8856-2000

Homologation: FIA 8856-2000

Homologation: SFI 3.3/5

Taglia • Size • Tamaño: 8-13

€ 129,00

**CARATTERISTICHE:** Precurvato. Tessuto monostrato su dorso e forchette traspirante e leggero. Cuciture esterne. Dorso e dita preformate. Elastico nel polsino. Sagomatura ergonomica del pollice. Tecnologia unica e brevettata FR: Touch Sensitive su indice e pollice. Palmo in tessuto doppio stampato con tecnologia HTX. Imbottitura nella zona carpale del palmo per ridurre impatti. Personalizzabili dal pronto.

**PERSONALIZZAZIONE:** stampa transfer.

**CHARACTERISTICS:** Pre-curved. Single-layer fabric on the back and between fingers, breathable and light. Back and fingers preformed, elastic wrist. Ergonomic profiling. Unique and FR patented technology: Touch Sensitive on index and thumb. Palm made of double-layer fabric using HTX technology, padding in the carpal region of the palm to reduce impact damage. New back graphic ready for personalisation.

**PERSONALISATION:** transfer print.



**CARACTERÍSTICAS:** Curvado de antemano. Tejido de una sola capa al dorso transpirable y ligero. Costuras externas. Dorso y dedos formados de antemano. Forma ergonómica del pulgar. Tecnología única y patentada FR: Touch Sensitive en índice y pulgar. Palma de tejido doble estampado con tecnología HTX. Acolchado en la zona carpiana de la palma para reducir los impactos.

**PERSONALIZACIÓN:** estampado transfer.



001309..RS



001309..AZ



001309..NRGR



001309..NRRS



001309..BI

# LAP RG-5



MANUFACTURER: SPARCO  
MODEL: RG-5  
FIA STANDARD: 8856-2000

Homologation: FIA 8856-2000

Homologation: SFI 3.3/5

Taglia • Size • Tamaño: 8-13

€ 79,00

**COMPOSIZIONE:** 93% maglina meta aramidica, 7% silicone.

**CARATTERISTICHE:** cuciture differenziate per un fitting migliore: esterne nel palmo, interne su dorso e dita. Dorso e dita preformate. Palmo con nuova stampa grip in silicone, scaricata per ridurre accumulo. Cinghietto per regolazione su polso ed elastici interni. Dorso con stampa serigrafica.

**PERSONALIZZAZIONE:** stampa transfer.

**COMPOSITION:** 93% meta-aramid mesh, 7% silicone.

**CHARACTERISTICS:** differentiated stitching for improving the fitting: external in the palm and internal on the back and fingers. Back and fingers are preformed. Palm with new silicone grip, smooth to reduce bunching. Belt closure for wrist and inner elastics adjustment. Screen-printed back.

**PERSONALISATION:** transfer print.

**COMPOSICIÓN:** 93% punto meta-aramidico, 7% silicona.

**CARACTERISTICAS:** costuras diferenciadas para mejorar el ajuste: externas en la palma e internas en el dorso y los dedos. El dorso y los dedos están preformados. Palma con nuevo estampado de agarre de silicona, descargada para reducir la acumulación. Correa para regulación en la muñeca y elásticos internos. Dorso con estampado serigráfico.

**PERSONALIZACIÓN:** estampado transfer.



001311..RS

001311..AZ

001311..NR

001311..NRGF

001311..NRAF

# LAND RG-3.1



MANUFACTURER: SPARCO  
MODEL: RG3/RG4/RG5  
FIA STANDARD: 8856-2000

Homologation: FIA 8856-2000

Homologation: SFI 3.3/5

Taglia • Size • Tamaño: 8-12

€ 65,00

Guanti a cuciture interne con palmo a strato singolo ultraleggero ed inserti in pregiata pelle scamosciata. Possibilità di personalizzazione secondo guideline Sparco.

**COMPOSIZIONE:** Maglina 100% meta-aramidica. Palmo con rinforzi in pelle scamosciata.

Gloves with internal seams, single-layer ultra-lightweight palm and quality suede inserts. Possibility of customisation following Sparco guidelines.

**COMPOSITION:** 100% meta-aramid jersey. Palm with suede reinforcements.

Guantes con costuras interiores con palma de capa individual ultraligera y aplicaciones en preciaada piel de ante. Posibilidad de personalización según las directrices Sparco.

**COMPOSICIÓN:** Tejido de punto 100% meta-aramida. Palma con refuerzos en piel de ante.



001308..RS

001308..AZ

001308..NR

# LAND CLASSIC



MANUFACTURER: SPARCO  
MODEL: RG3/RG4/RG5  
FIA STANDARD: 8856-2000

Homologation: FIA 8856-2000

Homologation: SFI 3.3/1

Taglia • Size • Tamaño: 8-12

€ 90,00

Guanti a cuciture interne con palma a strato singolo ultraleggero ed inserti in pregiata pelle scamosciata. Possibilità di personalizzazione secondo guideline Sparco.

**COMPOSIZIONE:** Maglino 100% meta-aramidica. Palma con rinforzi in pelle scamosciata.

Gloves with internal seams, single-layer ultra-lightweight palm and quality suede inserts. Possibility of customisation following Sparco guidelines.

**COMPOSITION:** 100% meta-aramid jersey. Palm with suede reinforcements.

Guantes con costuras interiores con palma de capa individual ultraligera y aplicaciones en preciosa piel de ante. Posibilidad de personalización según las directrices Sparco.

**COMPOSICIÓN:** Tejido de punto 100% meta-aramida. Palma con refuerzos en piel de ante.



001304..EC

001304..BM



GLOVES

105

PREZZI IVA ESCLUSA  
VAT NOT INCLUDED • PRECIOS SIN IVA

PREZZI IVA ESCLUSA  
VAT NOT INCLUDED • PRECIOS SIN IVA

RACING

104

RACING

# HELMETS



ISI®

# PRIME RF-9W SUPERCARBON



Il casco Prime RF-9W è realizzato con calotta in carbonio pre preg rinforzata con carbon-kevlar. Grazie a questa tecnologia costruttiva, il casco Prime RF-9W, ha un'elevata resistenza ed un peso contenuto. La calotta e i polistiroli sono in doppia misura, progettati e costruiti per garantire il massimo livello di ventilazione. Gli interni del casco sono smontabili, riposizionabili e lavabili. Il casco Prime RF-9W è predisposto per accogliere il drink system mentre la visiera (omologata FIA) è a regolazione continua. Fornito con clip Hans® già installate. In 6 taglie.

The Prime RF-9W helmet has a carbon fibre shell reinforced with carbon-kevlar. Thanks to this manufacturing technology, the lightweight Prime RF-9W has excellent resistance. The shell and EPS are manufactured in two sizes and have been designed to ensure excellent ventilation. The interior linings can be removed, washed and repositioned. The Prime RF-9W helmet can accommodate a drink system and the visor (FIA approved) can be easily adjusted. The Prime RF-9W comes supplied with Hans® clips fitted. Available in 6 sizes.

El casco Prime RF-9W tiene calotta de carbono prepreg reforzada con carbon-kevlar. Con esta tecnología constructiva, el casco Prime RF-9W ofrece una gran resistencia y escaso peso. La calota y los rellenos de poliestireno son en doble medida, diseñados y realizados para garantizar el máximo nivel de ventilación. Los elementos internos del casco son desmontables, recolocables y lavables. El casco Prime RF-9W está preparado para acoger el drink system mientras que la visera (homologada FIA) se puede ajustar continuamente. El casco Prime RF-9W lleva clips Hans® ya instalados. Disponible en 6 tallas.



MANUFACTURER: VM SAFETY  
MODEL: SPARCO PRIME RF-9W  
HOM. NO: AH.029.17-C  
FIA STANDARD: 8860-2010

CARBON		
XS	53-54	0033420XS
S	55-56	00033421S
M	57-58	0033422M
M+	59	0033423ML



MANUFACTURER: VM SAFETY  
MODEL: SPARCO PRIME RF-9W  
HOM. NO: AH.035.18-C  
FIA STANDARD: 8860-2010

L	60	0033424L
XL	61	0033425XL

Homologation: SNELL SA 2015

Homologation: FIA 8860-2010

CARBON

€ 1.890,00

# SKY RF-7W CARBON



Il casco SKY RF-7W è realizzato con calotta in carbonio rinforzata con strati carbon-kevlar. La calotta e i polistiroli sono in doppia misura, progettati e costruiti per garantire il massimo livello di ventilazione. Gli interni del casco sono smontabili, riposizionabili e lavabili. Il casco SKY RF-7 è predisposto per accogliere il drink system mentre la visiera (omologata FIA) è a regolazione continua. Il casco SKY RF-7W è fornito con clip Hans® già installate. Disponibile in 6 taglie.

The SKY RF-7W helmet has a carbon fibre shell reinforced with layers of carbon-kevlar. The shell and EPS are manufactured in two sizes and has been designed to ensure excellent ventilation. The interior linings can be removed, washed and repositioned. The SKY-7W helmet can accommodate a drink system and the visor (FIA approved) can be easily adjusted. The SKY-7W comes supplied with Hans® clips fitted. Available in 6 sizes.

El casco SKY RF-7W tiene calotta de carbono reforzada con capas de carbon-kevlar. La calota y los rellenos de poliestireno son en doble medida, diseñados y realizados para garantizar el máximo nivel de ventilación. Los elementos internos del casco son desmontables, recolocables y lavables. El casco SKY RF-7 está preparado para acoger el drink system mientras que la visera (homologada FIA) se puede ajustar continuamente. El casco SKY RF-7W lleva clips Hans® ya instalados. Disponible en 6 tallas.



MANUFACTURER: VM SAFETY  
MODEL: SPARCO SKY RF-7W  
HOM. NO: PH.038.16-C  
FIA STANDARD: 8859-2015

CARBON		
XS	53-54	0033440XS
S	55-56	00033441S
M	57-58	0033442M
M+	59	0033443ML

Homologation: SNELL SA 2015

Homologation: FIA 8859-2015

CARBON

€ 790,00

Homologation: SNELL SA 2015

Homologation: FIA 8859-2015

CARBON

€ 790,00



# AIR PRO RF-5W

# CLUB X-1



Il casco AIR PRO RF-5W è realizzato con calotta in vetroresina rinforzata con strati carbon-kevlar. La calotta e i polistiroli sono in doppia misura, progettati e costruiti per garantire il massimo livello di ventilazione. Gli interni del casco sono smontabili, riposizionabili e lavabili. Il casco AIR PRO RF-5W è predisposto per accogliere il drink system mentre la visiera (omologata FIA) è a regolazione continua. Il casco AIR PRO RF-5W è fornito con clip Hans® già installate. Disponibile in 7 taglie e due differenti colori.

The AIR PRO RF-5W helmet has a carbon fibre shell reinforced with layers of carbon-Kevlar. The shell and EPS are manufactured in two sizes and have been designed to ensure excellent ventilation. The interior linings can be removed, washed and repositioned. The AIR PRO RF-5W helmet can accommodate a drink system and the visor (FIA approved) can be constantly adjusted. The AIR PRO RF-5W comes supplied with Hans® clips fitted. Available in 7 sizes and in two colours.

El casco AIR PRO RF-5W tiene calota de fibra de vidrio reforzada con capas de carbon-kevlar. La calota y los rellenos de poliestireno son en doble medida, diseñados y realizados para garantizar el máximo nivel de ventilación. Los elementos internos del casco son desmontables, recolocables y lavables. El casco AIR PRO RF-5W está preparado para acoger el drink system mientras que la visera (homologada FIA) se puede ajustar continuamente. El casco AIR PRO RF-5W lleva clips Hans® ya instalados. Disponible en 7 tallas y dos colores diferentes.

Calotta in ATM (advance thermo material). Interno completamente estraibile e lavabile. Noleggio Kart  
**Non omologato per competizioni FIA. Non ignifugo.**

ATM (Advance Thermo Material) shell. Removable and washable inner lining. Kart indoor.  
**Not homologated for FIA competition. Not fireproof.**

Carcasa en ATM (Advance Thermo Material). Interior estraible y lavable. Alquiler Kart.  
**No homologado para eventos FIA. No ignifugo.**



MANUFACTURER: VM SAFETY  
MODEL: SPARCO AIR FR-5W  
HOM. NO.: PH.037.18-C  
FIA STANDARD: 8859-2015

Homologation: SNELL SA 2015

Homologation: FIA 8859-2015

KEVLAR/FIBERGLASS

€ 495,00

WHITE

XS	53-54	0033450XS
S	55-56	00033451S
M	57-58	0033452M
M+	59	0033453ML
L	60	0033454L
XL	61	0033455XL
XXL	62	0033456XXL

MATT BLACK

XS	53-54	0033450XSNR
S	55-56	00033451SNR
M	57-58	0033452MNR
M+	59	0033453MLNR
L	60	0033454LNR
XL	61	0033455XLNR
XXL	62	0033456XXLNR

Homologation: ECE 22-05

NOT FIA Homologated

ATM

€ 85,00

WHITE

XS	53-54	0033190XS
S	55-56	0033191S
M	57-58	0033192M
L	59	0033193L
XL	60	0033194XL
XXL	61	0033195XXL

MATT BLACK

XS	53-54	0033190XSNR
S	55-56	0033191SNR
M	57-58	0033192MNR
L	59	0033193LNR
XL	60	0033194XNL
XXL	61	0033195XXLNR

# PRIME RJ-9i SUPERCARBON



Calotta in carbonio pre preg rinforzata con carbon-kevlar. Grazie a questa tecnologia costruttiva, il casco Prime RJ-9i, ha un'elevata resistenza ed un peso contenuto. La calotta e polistiroli in doppia misura, progettati per garantire il massimo livello di ventilazione. Interni sono smontabili, riposizionabili e lavabili. Il casco Prime RJ-9i è fornito con sistema di comunicazione professionale (braccetto regolabile in fibra di carbonio, microfono a cancellazione del rumore, speaker alta qualità) e connessioni di derivazione militare (connettore Nexus pressofuso). Fornito con frontino in fibra di carbonio e clip Hans® già installate.

The Prime RJ-9i helmet has a carbon fibre shell reinforced with carbon-Kevlar. Thanks to this manufacturing technology, the lightweight Prime RJ-9i has excellent resistance. The shell and EPS are manufactured in two sizes and have been designed to ensure excellent ventilation. The interior linings can be removed, washed and repositioned. The Prime RJ-9i comes supplied with a professional communications system (adjustable carbon fibre boom, noise cancelling microphone, high quality speaker) and military grade connections (Nexus connector). The Prime RJ-9i comes supplied with Hans® clips fitted.

Calotta de carbonio prepreg reforzada con carbon-kevlar. Con esta tecnología constructiva, el casco Prime RJ-9i, ofrece una gran resistencia y escaso peso. La calota y los rellenos de poliestireno son en doble medida, diseñados para garantizar el máximo nivel de ventilación. Elementos internos desmontables, recolocables y lavables. Incorpora sistema de comunicación profesional (varilla regulable en fibra de carbono, micrófono con supresión del ruido, altavoz de alta calidad) y conexiones de derivación militar (conector Nexus fundido a presión). El casco Prime RJ-9i lleva frontal de fibra de carbono y clips Hans® ya instalados.



MANUFACTURER: VM SAFETY  
MODEL: SPARCO PRIME RJ-9i  
HOM. NO: AH.030.17-C  
FIA STANDARD: 8860-2010

	CARBON	
XS	53-54	0033460XS
S	55-56	0033461S
M	57-58	0033462M
M+	59	0033463ML
L	60	0033464L
XL	61	0033465XL

Homologation: SNELL SA 2015

Homologation: FIA 8860-2010

CARBON

€ 1.890,00

# SKY RJ-7i CARBON



Il casco SKY RJ-7i è realizzato con calotta in carbonio, rinforzata con carbon-kevlar. La calotta e i polistiroli sono in doppia misura, progettati e costruiti per garantire il massimo livello di ventilazione. Gli interni del casco sono smontabili, riposizionabili e lavabili. Il casco SKY RJ-7i è fornito con sistema di comunicazione professionale (braccetto regolabile in fibra di carbonio, microfono a cancellazione del rumore, speaker alta qualità) e connessioni di derivazione militare (connettore Nexus pressofuso). Il casco SKY RJ-7i è fornito con frontino in fibra di carbonio e clip Hans® già installate. Disponibile in 6 taglie.

The SKY-RJ-7i helmet has a carbon fibre shell reinforced with carbon-Kevlar. The shell and EPS are manufactured in two sizes and have been designed to ensure excellent ventilation. The interior linings can be removed, washed and repositioned. The SKY RJ-7i comes supplied with a professional communications system (adjustable carbon fibre boom, noise cancelling microphone, high quality speaker) and military grade connections (Nexus connector). The SKY RJ-7i comes supplied with a carbon fibre peak and Hans® clips fitted. Available in 6 sizes.

El casco SKY RJ-7i tiene calota de carbonio reforzada con carbon-kevlar. La calota y los rellenos de poliestireno son en doble medida, diseñados y realizados para garantizar el máximo nivel de ventilación. Los elementos internos del casco son desmontables, recolocables y lavables. El casco SKY RJ-7i incorpora sistema de comunicación profesional (varilla regulable en fibra de carbono, micrófono con supresión del ruido, altavoz de alta calidad) y conexiones de derivación militar (conector Nexus fundido a presión). El casco SKY RJ-7i lleva frontal de fibra de carbono y clips Hans® ya instalados. Disponible en 6 tallas.



MANUFACTURER: VM SAFETY  
MODEL: SPARCO SKY RJ-7i  
HOM. NO: PH.041.16-O  
FIA STANDARD: 8859-2015

	CARBON	
XS	53-54	0033470XS
S	55-56	00033471S
M	57-58	0033472M
M+	59	0033473ML
L	60	0033474L
XL	61	0033475XL

Homologation: SNELL SA 2015

Homologation: FIA 8859-2015

CARBON

€ 845,00

# SKY RJ-7 CARBON



Il casco SKY RJ-7 è realizzato con calotta in carbonio, rinforzata con carbon-kevlar. La calotta e i polistiroli sono in doppia misura, progettati e costruiti per garantire il massimo livello di ventilazione. Gli interni del casco sono smontabili, riposizionabili e lavabili. Il casco SKY RJ-7 è fornito con frontino in fibra di carbonio e clip Hans® già installate. Disponibile in 6 taglie.

The SKY-RJ-7 helmet has a carbon fibre shell reinforced with carbon-Kevlar. The shell and EPS are manufactured in two sizes and have been designed to ensure excellent ventilation. The interior linings can be removed, washed and repositioned. The SKY RJ-7 comes supplied with a carbon fibre peak and Hans® clips fitted. Available in 6 sizes.

El casco SKY RJ-7 tiene calota de carbono reforzada con carbon-kevlar. La calota y los rellenos de poliestireno son en doble medida, diseñados y realizados para garantizar el máximo nivel de ventilación. Los elementos internos del casco son desmontables, recolocables y lavables. El casco SKY RJ-7 lleva frontal de fibra de carbono y clips Hans® ya instalados. Disponible en 6 tallas.



MANUFACTURER: VM SAFETY  
MODEL: SPARCO SKY RJ-7  
HOM. NO: PH.041.16-O  
FIA STANDARD: 8859-2015

	■ CARBON		
XS	53-54	0033480XS	
S	55-56	0033481S	
M	57-58	0033482M	
M+	59	0033483ML	
L	60	0033484L	
XL	61	0033485XL	

Homologation: SNELL SA 2015

Homologation: FIA 8859-2015

CARBON

€ 750,00

# AIR PRO RJ-5i



Calotta in vetroresina, rinforzata con carbon-kevlar. Calotta e polistiroli in doppia misura, progettati per la massima ventilazione. Interni smontabili, riposizionabili e lavabili. Sistema di comunicazione professionale (braccetto regolabile in fibra di carbonio, microfono a cancellazione del rumore, speaker alta qualità) e connessioni di derivazione militare (connettore Nexus pressofuso). Frontino in tinta con la calotta e clip Hans® già installate. Disponibile in 7 taglie e due differenti colori.

The AIR PRO RJ-5i helmet has a carbon fibre shell reinforced with carbon-Kevlar. The shell and EPS are manufactured in two sizes and have been designed to ensure excellent ventilation. The interior linings can be removed, washed and repositioned. The AIR PRO RJ-5i comes supplied with a professional communications system (adjustable carbon fibre boom, noise cancelling microphone, high quality speaker) and military grade connections (Nexus connector). The AIR PRO RJ-5i comes supplied with a colour coded carbon fibre peak and Hans® clips fitted. Available in 7 sizes and in two colours.

Calota de fibra de vidrio reforzada con carbon-kevlar. La calota y los rellenos de poliestireno son en doble medida, diseñados para el máximo nivel de ventilación. Internos desmontables, recolocables y lavables. Incorpora sistema de comunicación profesional (varilla regulable en fibra de carbono, micrófono con supresión del ruido, altavoz de alta calidad) y conexiones de derivación militar (conector Nexus fundido a presión). Frontal del mismo color que la calota y clips Hans® ya instalados. Disponible en 7 tallas y dos colores diferentes.



MANUFACTURER: VM SAFETY  
MODEL: SPARCO PRO RJ-5i AIR  
HOM. NO: PH.042.16-O  
FIA STANDARD: 8859-2015

	□ WHITE			■ MATT BLACK		
XS	53-54	0033490XS	XS	53-54	0033490XSNR	
S	55-56	00033491S	S	55-56	00033491SNR	
M	57-58	0033492M	M	57-58	0033492MNR	
M+	59	0033493ML	M+	59	0033493MLNR	
L	60	0033494L	L	60	0033494LNR	
XL	61	0033495XL	XL	61	0033495XLNR	
XXL	62	0033496XXL	XXL	62	0033496XXLNR	

Homologation: SNELL SA 2015

Homologation: FIA 8859-2015

KEVLAR/FIBERGLASS

€ 625,00

# PRO RJ-3i



Il casco PRO RJ-3i è realizzato con calotta in vetroresina, rinforzata con carbon-kevlar. La calotta e i polistiroli sono in doppia misura, progettati e costruiti per garantire il massimo livello di ventilazione. Gli interni del casco sono smontabili, riposizionabili e lavabili. Il casco PRO RJ-3i è fornito con sistema di comunicazione integrato (braccetto regolabile, speaker alta qualità) e connessioni di derivazione militare (connettore Nexus pressofuso). Il casco PRO RJ-3i è fornito con clip Hans® già installate. Disponibile in 7 taglie.

The AIR PRO RJ-3i helmet has a fiberglass shell reinforced with carbon-Kevlar. The shell and EPS are manufactured in two sizes and have been designed to ensure excellent ventilation. The interior linings can be removed, washed and repositioned. The PRO RJ-3i comes supplied with a professional communications system (adjustable carbon fibre boom, noise cancelling microphone, high quality speaker) and military grade connections (Nexus connector). The AIR PRO RJ-3i comes supplied with Hans® clips fitted. Available in 7 sizes.

El casco PRO RJ-3i tiene calota de fibra de vidrio reforzada con carbon-kevlar. La calota y los rellenos de poliestireno son en doble medida, diseñados y realizados para garantizar el máximo nivel de ventilación. Los elementos internos del casco son desmontables, recolocables y lavables. El casco PRO RJ-3i incorpora sistema de comunicación profesional (varilla regulable, altavoz de alta calidad) y conexiones de derivación militar (conector Nexus fundido a presión). El casco PRO RJ-3i lleva clips Hans® ya instalados. Disponible en 7 tallas.



MANUFACTURER: VM SAFETY  
MODEL: SPARCO PRO RJ-3i  
HOM. NO: PH.042.16-O  
FIA STANDARD: 8859-2015

Homologation: SNELL SA 2015

Homologation: FIA 8859-2015

KEVLAR/FIBERGLASS

€ 459,00

	WHITE	
XS	53-54	0033520XS
S	55-56	0033521S
M	57-58	0033522M
M+	59	0033523ML
L	60	0033524L
XL	61	0033525XL
XXL	62	0033526XXL

# PRO RJ-3



Il casco PRO RJ-3 è realizzato con calotta in vetroresina, rinforzata con carbon-kevlar. La calotta e i polistiroli sono in doppia misura, progettati e costruiti per garantire il massimo livello di ventilazione. Gli interni del casco sono smontabili, riposizionabili e lavabili. Il casco PRO RJ-3 è fornito con clip Hans® già installate. Disponibile in 7 taglie.

The PRO RJ-3 helmet has a fiberglass shell reinforced with carbon-Kevlar. The shell and EPS are manufactured in two sizes and have been designed to ensure excellent ventilation. The interior linings can be removed, washed and repositioned. The PRO RJ-3 comes supplied with Hans® clips fitted. Available in 7 sizes.

El casco PRO RJ-3 tiene calota de fibra de vidrio reforzada con carbon-kevlar. La calota y los rellenos de poliestireno son en doble medida, diseñados y realizados para garantizar el máximo nivel de ventilación. Los elementos internos del casco son desmontables, recolocables y lavables. El casco PRO RJ-3 lleva clips Hans® ya instalados. Disponible en 7 tallas.



MANUFACTURER: VM SAFETY  
MODEL: SPARCO PRO RJ-3  
HOM. NO: PH.042.16-O  
FIA STANDARD: 8859-2015

Homologation: SNELL SA 2015

Homologation: FIA 8859-2015

KEVLAR/FIBERGLASS

€ 299,00

	WHITE	
XS	53-54	0033530XS
S	55-56	0033531S
M	57-58	0033532M
M+	59	0033533ML
L	60	0033534L
XL	61	0033535XL
XXL	62	0033536XXL

# CLUB J-1



Calotta in ATM (Advanced Thermo Material). Omologazione ECE-05. Fornito di frontino antiscia. Interno materiale analergico. Taglie XS (54) - XL (61).  
**Non omologato per competizioni FIA.**  
**Non ignifugo.**

ATM (Advanced Thermo Material) shell. ECE approved. Anti-dazzle peak. Hypoallergenic lining. Sizes XS (54) - XL (61).  
**Not homologated for FIA competition.**  
**Not fireproof.**

Carcasa en ATM ( Advanced Thermo material). Homologacion ECE-05. Visera para el sol. Material analergico al interior. Tallas desde XS (54) hasta XL (61).  
**No homologado para eventos FIA.**  
**No ignifugo.**

Homologation: ECE 22-05

NOT FIA Homologated

ATM

€ 69,00

☐ WHITE

XS	-54	0033170XS
S	55-56	0033171S
M	57-58	0033172M
L	59-60	0033173L
XL	61-	0033174XL

## ACCESSORIES - JET HELMETS

☐ = STANDARD/RICAMBIO - STANDARD/SPARE - STANDARD/REPUESTOS    ☐ = OPTIONAL - OPTION - EXTRAS

	INTERCOM SYSTEM	BLACK ABS PEAK	WHITE ABS PEAK	MATT BLACK ABS PEAK	CARBON PEAK 8869	CARBON PEAK 8860	CARBON BOOM 8859	SET OF SMALL MATT BLACK AIR INTAKES	SET OF SMALL WHITE AIR INTAKES
<b>PRIME RJ-9i</b>	FACTORY FITTED	00316F01	00316F03	00316F02	00316F04	FACTORY FITTED	537010	00315K04	0032WTXK06
<b>SKY RJ-7i</b>	FACTORY FITTED	00316F01	00316F03	00316F02	FACTORY FITTED	00316F05	537010	00315K04	0032WTXK06
<b>SKY RJ-7</b>	NOT FITTABLE	00316F01	00316F03	00316F02	FACTORY FITTED	00316F05	NOT FITTABLE	00315K04	0032WTXK06
<b>AIR PRO RJ-5i WHITE</b>	FACTORY FITTED	00316F01	00316F03	00316F02	00316F04	00316F05	537010	00315K04	0032WTXK06
<b>AIR PRO RJ-5i BLACK</b>	FACTORY FITTED	00316F01	00316F03	00316F02	00316F04	00316F05	537010	00315K04	0032WTXK06
<b>PRO RJ-3i</b>	FACTORY FITTED	00316F01	00316F03	00316F02	00316F04	00316F05	537010	00315K04	0032WTXK06
<b>PRO RJ-3</b>	NOT FITTABLE	00316F01	00316F03	00316F02	00316F04	00316F05	NOT FITTABLE	00315K04	0032WTXK06

## ACCESSORIES - FULL FACE HELMETS

☐ = STANDARD/RICAMBIO - STANDARD/SPARE - STANDARD/REPUESTOS    ☐ = OPTIONAL - OPTION - EXTRAS

	CLEAR VISOR	DARK VISOR	BLUE IRIDIUM VISOR	SILVER IRIDIUM VISOR	SET OF 5 TEAR-OFFS	VISOR FASTENER KIT	CENTRAL MATT BLACK AIR INTAKE	SET OF SMALL MATT BLACK AIR INTAKES	CENTRAL WHITE AIR INTAKE	SET OF SMALL WHITE AIR INTAKES
<b>PRIME RF-9W</b>	00314V01	00314V02	00314V03	00314V04	00315K01	00315K02	00315K03	00315K04	0032WTXK04	0032WTXK06
<b>SKY RF-7W</b>	00314V01	00314V02	00314V03	00314V04	00315K01	00315K02	00315K03	00315K04	0032WTXK04	0032WTXK06
<b>AIR PRO RF-5W WHITE</b>	00314V01	00314V02	00314V03	00314V04	00315K01	00315K02	00315K03	00315K04	0032WTXK04	0032WTXK06
<b>AIR PRO RF-5W BLACK</b>	00314V01	00314V02	00314V03	00314V04	00315K01	00315K02	00315K03	00315K04	0032WTXK04	0032WTXK06
<b>AIR KF-7W</b>	00314V01	00314V02	00314V03	00314V04	00315K01	00315K02	00315K03	00315K04	0032WTXK04	0032WTXK06
<b>SKY KF-5W</b>	00314V01	00314V02	00314V03	00314V04	00315K01	00315K02	00315K03	00315K04	0032WTXK04	0032WTXK06

ACCESSORI • ACCESSORIES • ACCESORIOS



CLEAR VISOR € 69,00

00314V01



DARK VISOR € 89,00

00314V02



SILVER IRIIDIUM VISOR € 89,00

00314V04



BLUE IRIIDIUM VISOR € 89,00

00314V03



SET OF 5 TEAR-OFFS € 22,00

00315K01



SET OF WHITE AIR INTAKES € 36,00

0032WTXK04



SET OF BLACK AIR INTAKES € 36,00

0032WTXK04



VISOR FASTENER KIT € 27,00

00315K02



SUPERCARBON PEAK 8860 € 142,50

00316F05



CARBON PEAK 8859 € 127,00

00316F04



WHITE ABS PEAK € 22,00

00316F03



BLACK ABS PEAK € 29,00

00316F01



MATT BLACK ABS PEAK € 39,00

00316F02

## ACCESSORI • ACCESSORIES • ACCESORIOS

**KIT INTERFONO PER CASCHI INTEGRALI**  
INTERCOM KIT FOR FULL-FACE HELMETS  
KIT INTERFONO PARA CASCOS INTEGRALES

**NEW**



€ 170,00

Kit interfono per caschi integrali - Connessione Nexus - Microfono a cancellazione del rumore, speaker di alta qualità.  
Intercom kit for full-face helmets - Nexus Connection - Noise cancelling microphone, high-quality speakers.  
Kit interfono para cascos integrales - Conexión Nexus - Micrófono con supresión de ruido, altavoz de alta calidad.

00537025

**KIT INTERFONO PER CASCHI JET**  
INTERCOM KIT FOR JET HELMETS  
KIT INTERFONO PARA CASCOS JET

**NEW**



€ 170,00

Kit interfono per caschi jet - Connessione Nexus - Microfono a cancellazione del rumore installato su braccetto flessibile.  
Intercom kit for jet helmets - Nexus Connection - Noise cancelling microphone installed on flexible arm.  
Kit interfono para cascos Jet - Conexión Nexus - Micrófono con supresión de ruido montado en varilla flexible.

00537026



€ 35,00

Kit interfonico per caschi integrali.  
Intercom kit for full-face helmets.  
Juego de intercomunicadores para cascos integrales.

00537013



€ 45,00

Kit interfonico per caschi jet.  
Intercom kit for jet helmets.  
Juego de intercomunicadores para cascos jet.

00537011



€ 86,00

Cavo telefono per IS-140  
Phone cable for IS-140  
Cable de telefono para el IS-140  
Compatible con - Compatible with  
I-Phone, Blackberry, Nokia, Samsung.

00537020



€ 75,00

Adattatore Nexus F-F  
Nexus F-F adaptor  
Adaptador Nexus F-F

00537015



€ 75,00

Adattatore Nexus M-M  
Nexus M-M adaptor  
Adaptador Nexus M-M

00537019



**IMBOTTITURA GUANCE - CHEEK PADDING - MULLIDO EN LA PARTE DE LAS MEJILLAS (Full face helmets)**

25 mm	0032RF01ML	€ 39,00
30 mm	0032RF01MXLXXL	
35 mm	0032RF01SL	
40 mm	0032RF01XS	



**IMBOTTITURA TOP - TOP PADDING - MULLIDO DE LA PARTE SUPERIOR (Full face and Jet helmets)**

10 mm	0032R01XXL	€ 10,00
15 mm	0032R01MMLLXL	
15+5 mm	0032R01XS	

Questi kit consentono di adattare al meglio il fitting del casco, scegliendo lo spessore adeguato alle proprie esigenze. L'installazione è semplice e veloce, grazie al fissaggio attraverso velcro. • These kits allow for the best possible helmet fitting, with the right choice of thickness for the user's needs. Installation is simple and rapid, thanks to the Velcro fastenings. • Estos kits permiten adaptar mejor el ajuste del casco al poder elegir el espesor adecuado para cada necesidad. La instalación es fácil y rápida gracias a la fijación con velcro.



**SPOILER ANTERIORE**  
FRONT SPOILER  
ALERÓN ANTERIOR

Lo spoiler anteriore riduce le vibrazioni del casco alle alte velocità stabilizzandolo e rendendolo più confortevole.  
The front spoiler reduces high-speed helmet vibrations to stabilise the helmet and make it more comfortable.  
El alerón anterior reduce las vibraciones del casco en las situaciones de alta velocidad estabilizándolo y haciéndolo más cómodo.

BLACK	00315K08	€ 12,00
WHITE	00315K07	



**SPOILER POSTERIORE**  
REAR SPOILER  
ALERÓN POSTERIOR

Lo spoiler posteriore stabilizza il casco alle alte velocità ed al tempo stesso favorisce l'estrazione dell'aria calda dal casco.  
The rear spoiler stabilises the helmet at high speeds and at the same time facilitates hot air extraction from the helmet.  
El alerón posterior estabiliza el casco en las situaciones de alta velocidad y favorece la extracción del aire caliente del casco.

BLACK	00315K10	€ 15,00
WHITE	00315K09	



**PUMPER**

XS-M/L	00317P02	€ 19,00
L-XXL	00317P04	
XS-M/L	00317P01	
L-XXL	00317P03	

Microfono a cancellazione del rumore. Posizione del microfono regolabile. Cover in vera fibra di carbonio, prodotta con tecnologie innovative. Compatibile con PRIME RJ-9i, SKY RJ-7i, AIR PRO RJ-5i.

Noise cancelling microphone. Adjustable microphone position. Covered in carbon fibre made using innovative technologies. Compatible with PRIME RJ-9i, SKY RJ-7i and AIR PRO RJ-5i.

Micrófono con supresión del ruido. Posición del micrófono regulable. Tapa de auténtica fibra de carbono, fabricada con tecnologías innovadoras. Compatible con PRIME RJ-9i, SKY RJ-7i, AIR PRO RJ-5i.



PRIME RJ-9i € 160,00

00537004



SKY RJ-7i - AIR PRO RJ-5i € 120,00

00537010

# COSMOS

H 35 x L35 x P 40 . 50 Lt

€ 65,00

Borsa porta casco e collare hans. Tessuto poliestere 600, neoprene e inserti in pelle sintetica. Sistema di asciugatura casco con alimentazione USB 12V. Soffietto per aumentare la capienza della borsa. Fascia tracolla regolabile. Due maniglie. Materiale resistente all'acqua. Copertura ventola.

Helmet and HANS bag. 600 polyester fabric, neoprene and synthetic leather inserts. Drying system helmet with USB 12V power. Divider to increase the capacity of the bag. Adjustable shoulder strap. Two carry handles. Water resistant material. Ventilation cover.

Bolso porta casco y collarín HANS. Tejido de poliéster 600, neopreno y aplicaciones de piel sintética. Sistema de secado del casco con alimentación USB 12V. Fuelle para aumentar la capacidad del bolso. Correa bandolera ajustable. Dos asas. Material resistente al agua. Cubierta del ventilador.

## BORSA PORTA CASCO HELMET BAG BOLSA PORTA CASCO

€ 37,50



003112NGR

## RETE PORTA CASCHI HELMET NET RED PORTA CASCOS

€ 49,00



00313



016433NR

## PORTA CASCHI HELMET BOXES PORTA CASCOS

€ 59,00



Nuova versione in similpelle lavabile.  
New edition made of washable vinyl.  
Nueva ediccion en finta piel lavable.

01662R 01662A 01662N



€ 30,00

01666

## COLLARI SUPPORTO CASCO NECK SUPPORT COLLARS COLLARÍN SOPORTE CASCO

€ 85,00



Caratterizzato dalla particolare forma anatomica posteriore e dall'imbottitura a densità differenziata (più consistente nelle zone di appoggio del casco e più morbida sotto il mento e nello spoiler) per attenuare il peso del casco sulla schiena.

Characterized by a special rear anatomic shape and variable density padding (more consistent in the helmet support area and softer under the chin and in the spoiler) in order to reduce the weight of the helmet on the back.

Caracterizado por su particular forma anatómica de la parte de atrás y por el mullido de densidad diferenciada (más consistente en las zonas de apoyo del casco y más suave en la parte del mentón y en el spoiler) para atenuar el peso del casco en la espalda.



001603AZNR 001603RSNR 001603GRNR



€ 65,00



001601AZNR 001601RSNR 001601GRNR



# HANS DEVICES

Grazie ad nuovo accordo commerciale Sparco è in grado di offrire la migliore gamma di Head Restraint per taglie, conformazione, peso e prezzo. Inoltre, grazie alla costante cura per i suoi prodotti, è la sola azienda in grado di fornire ai clienti un pacchetto completo di prodotti compatibile con il sistema (casco, cintura e sedile).

Thanks to the new trade agreement, Sparco is able to provide the best range of Head Restraint for sizes, structure, weight and price. Moreover, thanks to the usual care for its products, Sparco is the only factory able to provide to customers a full package compatible with the set (helmet, harness and seat).

Gracias a un nuevo acuerdo comercial, Sparco puede ofrecer la mejor gama de Head Restraint en lo que se refiere a tamaño, modelo, peso y precio. Además, gracias al cuidado constante de su productos, es la única empresa capaz de facilitar a sus clientes un paquete completo de productos compatibles con el sistema (casco, cinturón y asiento).

## ULTIMATE

Realizzato 100% carbonio  
Peso: 490 g (senza imbottiture)  
Fitting migliorato  
Cinghietto scorrevole

100% carbon  
Weight: 490 g (without padding)  
Improved fitting  
Sliding Tethers

Fabricado en fibra de carbon 100%  
Peso: 490 g (sin acolchado)  
Ajuste optimizado  
Correa deslizable.

€ 1.099,00



DEGREE	SIZES
20	M
20	L
30	M
30	L

00393U...

## HI TECH

Realizzato in carbonio  
Peso: 550 g circa  
Disponibilità in tutte le taglie  
Tethers scorrevoli

Carbon made  
Weight: about 550 g  
All sizes available  
Sliding Tethers

Fabricado en carbono  
Peso: aproximadamente 550 g  
Disponibilidad en todos los talles  
Correas movedizas

€ 855,00



DEGREE	SIZES
10	M
20	S - M - L
25	S
30	M - L
30	SPECIAL M - L
40	M

00391N...

## CLUB 3

NEW

Costruzione in materiale termoplastico  
Peso: 640g  
Disponibile in due taglie  
Tethers scorrevoli

Made of thermoplastic material  
Weight: about 640g  
2 sizes available  
Sliding tethers

Fabricado en material termoplástico  
Peso : aproximadamente 640g  
Disponibile en dos talles  
Correas movedizas

€ 279,00



DEGREE	SIZES
20	M/L - L/XL

00394C20...

## CLUB

Realizzato in PVC ad alta resistenza  
Peso : 950 g circa  
Forma dal design ergonomico  
Tethers scorrevoli  
Prezzo contenuto

Realized in high resistance PVC  
Weight: around 950 g  
Ergonomic design shape  
Sliding Tethers  
Low price

Fabricado en PVC de alta resistencia  
Peso: aproximadamente 950 g  
Ergonómico  
Correas movedizas  
Precio módico

€ 225,00



DEGREE	SIZES
20	M/L - L/XL

00391C...

# IS-150 BT

## CENTRALINA INTERFONO DIGITALE DIGITAL INTERCOM BOX CENTRALITA DE INTERFONO DIGITAL



Centralina interfono digitale  
Cancellazione del rumore digitale, regolabile attraverso differenti preset  
Connessione con dispositivi mobili attraverso Bluetooth  
Modalità "Race" per disabilitare il collegamento con dispositivi mobili in prova speciale  
Uscita RCA per camera car  
Regolazione del volume indipendente tra pilota e navigatore.  
Connettori Nexus di derivazione militare.

€ 415,00

Digital intercom control unit  
Digital noise cancelling with different preset adjustment levels  
Bluetooth connection with mobile devices  
"Race" mode to disable communication with mobile devices in special stages  
RCA jack for in-car camera  
Independent volume control between driver and navigator.  
Military grade Nexus connectors.

Centralita de interfono digital  
Supresión del ruido digital, regulable mediante diferentes preajustes  
Conexión con dispositivos móviles a través de Bluetooth  
Modalidad "Race" para desactivar la conexión con dispositivos móviles en prueba especial  
Salida RCA para cámara car  
Regulación del volumen independiente entre piloto y copiloto.  
Conectores Nexus de derivación militar.

00537021

# IS-140

## CENTRALINA INTERFONO - INTERCOM BOX - CENTRALITA DE INTERFONO

Centralina interfono professionale pensata per offrire le migliori prestazioni nella comunicazione durante le competizioni automobilistiche. Sviluppata grazie all'ausilio dei piloti più importanti nel panorama nazionale e mondiale. Il suo punto forza è la qualità della comunicazione che riesce ad essere chiara in ogni situazione garantendo note precise e sicurezza all'equipaggio. Potenti filtri antirumore e la possibilità di tararli in ben sei combinazioni differenti la rendono perfettamente compatibile con le vetture più rumorose come le WRC e le S2000.

€ 195,00



**Caratteristiche tecniche IS-140:**  
Regolazione del volume indipendente tra pilota e navigatore  
Case progettato per facilitare il montaggio a rollbar e a pannello  
Connettori Nexus di derivazione militare femmina  
Cablaggi integrati al case a garanzia di resistenza nel tempo  
Alimentazione tramite pila 9v PP3 (non fornita) o batteria 12v della vettura (cavo integrato)  
3 filtri antirumore uniti a 2 impostazioni di amplificazione permettono un totale di 6 tarature dell'elettronica  
Appositamente studiata per caschi Sparco ma pienamente compatibile con i modelli diffusi sul mercato  
Accensione automatica all'inserimento del casco navigatore  
Led ON/OFF  
Connettore 3,5mm per telefono (I-Phone, Nokia, Samsung)  
Uscita audio RCA per camera car

**IS-140 Technical specification:**  
Independent volume adjusting (driver and co-driver)  
External shape is designed to fit easily to rollcage and panel  
Female Nexus military connectors  
Integrated internal cable for upgraded reliability  
Powered via a 9v PP3 battery (not supplied) or 12v car battery (integrated cable)  
3 noise reduction filters, 2 different amplification possibilities for a total of 6 settings  
Developed for Sparco crash helmets but totally compatible with most common crash helmets on the market  
Automatic switched on once the co-driver crash helmet is plugged in  
ON/OFF led signal  
3,5mm connector for mobile phone (I-Phone, Nokia, Samsung)  
RCA output for on board camera

**Especificaciones IS-140:**  
Ajuste de volumen independiente entre piloto y copiloto  
Centralita diseñada para facilitar su montaje en el arco o el panel  
Conector Nexus de derivación militar femmina  
Cableado integrado a la centralita como garantía de durabilidad  
Funciona con batería de 9v PP3 (No suministrada) o con la batería 12v del coche (cable integrado)  
3 Filtros de ruido combinados con 2 ajustes de amplificador que permiten un total de 6 artículos electrónicos de calibración  
Especialmente diseñado para los cascos Sparco pero totalmente compatible con los modelos más populares en el mercado  
Inserción automática del casco del copiloto  
Led ON/OFF  
Conector de 3,5mm para teléfono (I-Phone, Nokia, Samsung)  
Salida audio RCA para cámara en coche

00537016

# IS-110

## CENTRALINA INTERFONO - INTERCOM BOX - CENTRALITA DE INTERFONO

Centralina interfono di ottima qualità pensata per i professionisti che hanno bisogno di un prodotto semplice ed economico. Qualità audio elevata e facilità di utilizzo la rendono molto versatile e adatta ai più svariati utilizzi.

High quality intercom system designed for professionals that need a simple and economic product. High quality audio and easy-to-use system make this product perfect for a variety of uses.

Centralita de intercomunicación de más alta calidad diseñada para profesionales que necesitan un producto simple y barato. Alta calidad audio y facilidad de uso hacen que sea muy versátil y adecuado para muchos usos.

€ 75,00



### Caratteristiche tecniche IS-110:

Regolazione del volume pilota/navigatore tramite unica manopola  
Case progettato per facilitare il montaggio a rollbar e a pannello  
Connettori alta qualità 6,3mm femmina  
Cablaggi integrati al case a garanzia di resistenza nel tempo  
Alimentazione tramite pila 9v PP3 (non fornita) o batteria 12v della vettura (cavo integrato)  
Accensione su manopola  
Led ON/OFF

### IS-110 Technical specification:

One knob adjusts both driver and co-driver volumes  
External shape is designed to easily fit to rollcage and panel  
6.3 mm high quality connectors  
Integrated internal cable for an upgraded reliability  
Powered via a 9v PP3 battery (not supplied) or 12v car battery (integrated cable)  
Knob to switch on  
ON/OFF led signal

### Especificaciones IS-110 :

Ajuste del volumen de piloto / copiloto con un solo botón  
Centralita diseñada para facilitar su montaje en el arco o el panel  
Conectores de alta calidad 6,3mm hembra  
Cableado integrado a la centralita como garantía de durabilidad  
Funciona con batería de 9V PP3 (No suministrada) o con la batería 12V del coche (cable integrado)  
Encendido por botón  
Led ON/OFF

00537009



## CUFFIE DA TRASFERIMENTO HEADSETS CASCOS

Cuffia studiata per i tratti di strada aperta al traffico (rally/regolarità)  
Coppe ad elevata riduzione del rumore  
Microfono regolabile  
Connessione attraverso cavo spiralato e connettore

Headphones designed for use on open road (rallies/time trials)  
Excellent noise cancelling headphones  
Adjustable microphone  
Connection by means of spiral cable and connector

Cascos estudiados para los tramos de carretera abiertos al tráfico (rally/regularidad)  
Copas de alta reducción del ruido  
Micrófono regulable  
Conexión con cable helicoidal y conector

## HEAD NX1



€ 199,00

00537023

## HEAD R



€ 179,00

00537024

RACING

# SEATS



ISI<sup>®</sup>

# ADV XT



MANUFACTURER: SPARCO  
MODEL: ADV XT  
HOM. NO: AS.064.17  
FIA STANDARD: 8862-2009

Homologation: FIA 8862-2009

CARBON

€ 5.900,00

Ultraleggero, il sedile ADV XT ha un sistema di assorbimento di energia nelle aree più sollecitate, fodera con tessuto auto-estinguente e tessuto antiscivolo per il contenimento spalle e per la seduta. Posizione di guida e comfort migliorati, cuscino poggia gambe sdoppiato. Fissaggio attacchi laterali con interasse da 290 mm.

Ultra-lightweight, the ADV XT seat has an energy-absorption system in the areas subjected to the highest stress, a lining in self-extinguishing fabric and a non-slip fabric for restraining the shoulders and seat. Improved driving position and comfort, split leg rest cushion. Fixed using lateral fastenings with 290 mm spacing.

Ultraligero, el asiento ADV XT incorpora un sistema de absorción de energía en las partes mayormente sujetas a esfuerzos, forro con tejido autoextinguible y tejido antideslizante para la zona de hombros y para el asiento. Posición de conducción y comodidad mejoradas, cojín en dos partes para el apoyo de las piernas. Fijación con enganches laterales con una distancia entre ejes de 290 mm.

PESO - WEIGHT (g)  
SCocca-SHELL-ESTRUCTURA: 7500  
SEDILE-SEAT-ASIENTO: 10000

Il sedile è omologato in abbinamento con le staffe per attacco laterale 0049605.

The seat is approved in conjunction with the side mounting frames 0049605.

El asiento esta homologado juntos con los soportes laterales 0049605.

€ 250,00



0049605



ADV XT

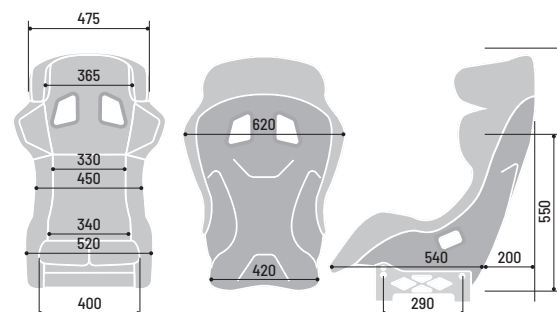

008002ZNR

## ADV ELITE



00849ZNR



MANUFACTURER: SPARCO  
MODEL: ADV ELITE  
HOM. NO: AS.037.14  
FIA STANDARD: 8862-2009

Homologation: FIA 8862-2009

CARBON

€ 5.500,00

Prestazioni ai massimi livelli, evoluzione dell' ADV-SCX, il design della scocca non ha solo funzione estetica ma strutturale e, unito al sistema di assorbimento di energia, conferisce al sedile una resistenza agli impatti senza pari. La riduzione dello spessore della scocca ed i miglioramenti al contenimento testa, uniti al grande studio ergonomico effettuato sulle imbottiture, ne aumentano l'abitabilità ed il comfort. Fissaggio attacchi laterali con interasse da 290 mm.

Giving top-level performance and an evolution of the ADV-SCX, the frame design has a structural as well as an aesthetic function and, together with an energy-absorption system, gives the seat unrivalled impact resistance. The reduced thickness of the frame and improvements to the head restraint, together with the carefully researched ergonomics of the padding, increase its habitability and comfort. Fixed using lateral fastenings with 290 mm spacing.

Máximos niveles de prestaciones, evolución del ADV-SCX, el diseño de la estructura no tiene solo una función estética sino también estructural y, junto con el sistema de absorción de energía, proporciona al asiento una resistencia sin igual a los impactos. La reducción del espesor de la estructura y las mejoras para mantener en posición la cabeza, junto con el estudio ergonómico a fondo efectuado para los acolchados, permiten aumentar su comodidad. Fijación con enganches laterales con una distancia entre ejes de 290 mm.

PESO - WEIGHT (g)  
SCocca-SHELL-ESTRUCTURA: 7810  
SEDILE-SEAT-ASIENTo: 10700

## ADV ELITE

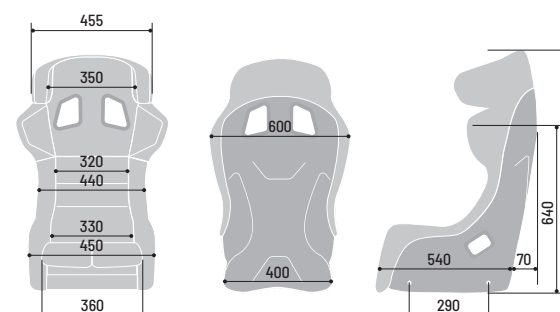

Il sedile è omologato in abbinamento con le staffe per attacco laterale 004988ADV.

The seat is approved in conjunction with the side mounting frames 004988ADV.

El asiento esta homologado juntos con los soportes laterales 004988ADV.

€ 375,00



004988ADV



## ADV SCX / SCX-H



MANUFACTURER: SPARCO  
MODEL: ADV SCX  
HOM. NO: AS.022.12  
FIA STANDARD: 8862-2009

Homologation: FIA 8862-2009

CARBON

ADV SCX € 5.100,00

ADV SCX-H € 5.200,00

Ultrarresistente, evoluzione del sedile ADV SC, ha un sistema di assorbimento di energia nelle aree più sollecitate, fodera con tessuto autoestinguento e tessuto antiscivolo per il contenimento spalle e per la seduta. Disponibile in 2 taglie (SCX e SCX-H), fissaggio attacchi laterali con interasse da 290 mm.

Ultra-strong and an evolution of the ADV SC, this has an energy-absorption system in the areas subjected to the highest stress, a lining in self-extinguishing fabric and a non-slip fabric for restraining the shoulders and for the seat. Available in 2 sizes (SCX and SCX-H), fixed using lateral fastenings with 290 mm spacing.

Ultrarresistente, evolución del asiento ADV SC, incorpora un sistema de absorción de energía en las partes mayormente sujetas a esfuerzos, forro con tejido autoextinguible y tejido antideslizante para la zona de hombros y para el asiento. Disponible en 2 tallas (SCX y SCX-H), fijación con enganches laterales con una distancia entre ejes de 290 mm.

## PESO - WEIGHT (g)

## SCocca-SHELL-ESTRUTURA

ADV SCX: 8575

ADV SCX-H: 9280

## SEDILE-SEAT-ASIENTO

ADV SCX: 10700

ADV SCX-H: 12500

Il sedile è omologato in abbinamento con le staffe per attacco laterale:

The seat is approved in conjunction with the side mounting frames:

El asiento esta homologado juntos con los soportes laterales:

€ 350,00



ADV SCX 004985ADV

ADV SCX-H 004984ADV

## ADV SCX - ADV SCX-H

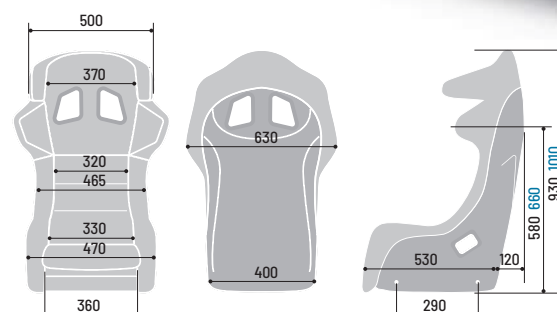

ADV SCX-H



MANUFACTURER: SPARCO  
MODEL: ADV SCX H  
HOM. NO: AS.016.11  
FIA STANDARD: 8862-2009



ADV SCX

□ 00804ZNR

□ 00805ZNR

CARBON

## ADV SC

CARBON

## PRO ADV

NEW

FIA APPROVED

MANUFACTURER: SPARCO  
 MODEL: ADV SC 19  
 HOM. NO.: AS.070.18  
 FIA STANDARD: 8862-2009

Homologation: FIA 8862-2009

CARBON

€ 3.495,00

Resistenza ai massimi livelli, capace di resistere ad oltre 3000kg di forza laterale, il sedile ADV SC ha un sistema di assorbimento di energia nelle aree più sollecitate, fodera con tessuto autoestinguente e tessuto antiscivolo per il contenimento spalle e per la seduta. Fissaggio attacchi laterali con interasse da 290 mm.

With strength at the top of its class and able to withstand over 3,000 kg of lateral force, the ADV SC seat has an energy-absorption system in the areas subjected to the highest stress, a lining in self-extinguishing fabric and a non-slip fabric for restraining the shoulders and for the seat. Fixed using lateral fastenings with 290 mm spacing.

Máximos niveles de resistencia, capaz de resistir a más de 3000 kg de fuerza lateral, el asiento ADV SC incorpora un sistema de absorción de energía en las partes mayormente sujetas a esfuerzos, forro con tejido autoextinguible y tejido antideslizante para la zona de hombros y para el asiento. Fijación con enganches laterales con una distancia entre ejes de 290 mm.

PESO - WEIGHT (g)  
 SCOCCA-SHELL-ESTRUTURA: 10485  
 SEDILE-SEAT-ASIENTO: 12000

Il sedile è omologato in abbinamento con le staffe per attacco laterale:

The seat is approved in conjunction with the side mounting frames:

El asiento esta homologado juntos con los soportes laterales:

€ 350,00



ADV SC 004982ADV

ADV SC

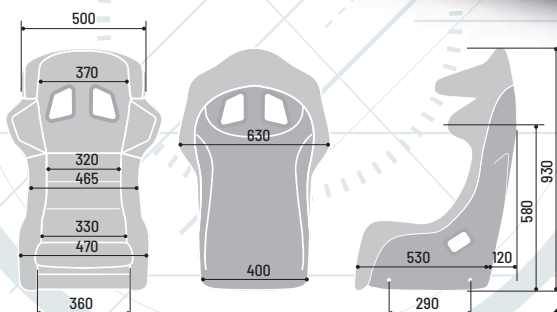

008020ZNR

FIA APPROVED

MANUFACTURER: SPARCO  
 MODEL: PRO ADV CF  
 HOM. NO.: CS.351.17  
 FIA STANDARD: 8855-1999

Homologation: FIA 8855-1999

CARBON

€ 2.200,00

Versione semplificata ed alleggerita dell'ADV SC, scocca e sellatura sono state pensate per avere la più ampia zona di protezione per la testa e per le spalle. Il sedile PRO ADV nasce per rispondere alle esigenze di massima sicurezza e leggerezza. Fissaggio attacchi laterali con interasse da 290 mm.

A simplified and lighter version of the ADV SC, the frame and upholstery have been designed to provide the widest area of protection for the head and shoulders. The PRO ADV seat was developed to respond to the need for maximum safety and lightness. Fixed using lateral fastenings with 290 mm spacing.

Versión simplificada y aligerada del ADV SC, estructura y asiento han sido diseñados para ofrecer la más amplia zona de protección para la cabeza y para los hombros. El asiento PRO ADV ha sido creado para responder a las exigencias de máxima seguridad y liviandad. Fijación con enganches laterales con una distancia entre ejes de 290 mm.

PESO - WEIGHT (g)  
 SCOCCA-SHELL-ESTRUTURA: 6000  
 SEDILE-SEAT-ASIENTO: 8100

PRO-ADV

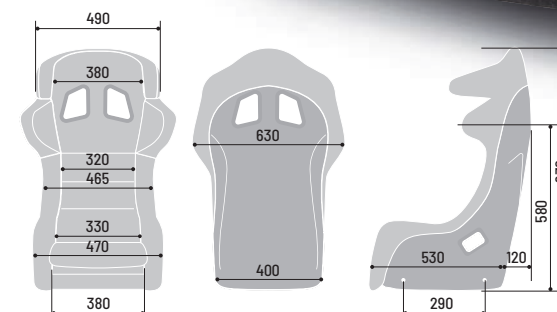

008095ZNR

RACING

141

PREZZI IVA ESCLUSA  
VAT NOT INCLUDED - PRECIOS SIN IVAPREZZI IVA ESCLUSA  
VAT NOT INCLUDED - PRECIOS SIN IVA

RACING

140





MANUFACTURER: SPARCO  
MODEL: QRT-C  
HOM. NO: CS.XXX.2018  
FIA STANDARD: 8855-1999

Homologation: FIA 8862-2009

QRT CARBON

€ 1.495,00

Progettato con l'utilizzo dei più innovativi software CAD il QRT-C è un sedile di nuovissima concezione. La scocca è stata progettata per essere installata anche negli abitacoli più angusti, il design aggressivo enfatizza la natura corsaia del sedile ed aumenta la rigidità strutturale. Nuovo cuscino diviso in 2 parti e nuovi ricami, scocca in carbonio di ultima generazione. Fissaggio attacchi laterali con interasse da 290 mm.

Designed using the most innovative CAD software available, the QRT-C seat is built around a brand new concept. The frame has been designed to be installed even in the narrowest car interiors, and its aggressive design emphasizes the seat's racing pedigree and increases its structural rigidity. It has a new cushion divided into 2 parts and new stitching, with a frame in latest-generation carbon. Fixed using lateral fastenings with 290 mm spacing.

Diseñado utilizando los software CAD más innovadores, el QRT-C es un nuevo concepto de asiento. La estructura ha sido diseñada para poder instalarla incluso en los habitáculos más estrechos, el diseño agresivo destaca el carácter deportivo del asiento y aumenta la rigidez estructural. Nuevo cojín dividido en 2 partes y nuevos bordados, estructura de carbono de última generación. Fijación con enganches laterales con una distancia entre ejes de 290 mm.

PESO - WEIGHT (g)  
SCocca-SHELL-ESTRUCTURA: 5300  
SEDILE-SEAT-ASIENTO: 6400



QRT-C

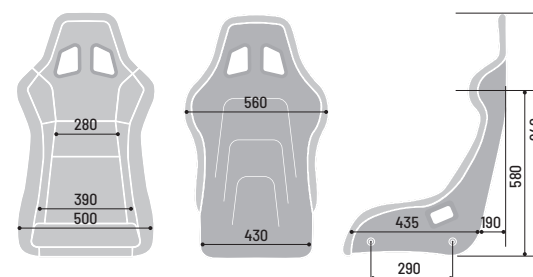

008005ZNR

# RACING

# QRT TECHNOLOGY

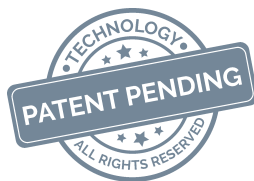

Studiato e sviluppato in Italia nei nostri laboratori, QRT è un processo tecnico all'avanguardia, basato su tecnologie di derivazione aerospaziale. Questo innovativo metodo di produzione è in grado di generare le scocche dei sedili in vetroresina più leggere e resistenti ad oggi in commercio; infatti garantisce una riduzione del peso complessivo pari al 30% rispetto ai più tradizionali metodi produttivi, determinando nuovi standard qualitativi, di performance e fitting del prodotto.

Designed and developed in Italy in our laboratories, QRT is a state-of-the-art technical process, based on aerospace technologies. This innovative production method is able to generate the lightest and most resistant fiberglass seat shells currently on the market; in fact, it guarantees a reduction in total weight of 30% compared to more traditional production methods, leading to new quality, performance and product fit standards.

Estudiado y desarrollado en Italia, en nuestros laboratorios, QRT es un proceso técnico a la vanguardia, basado en tecnologías del sector aeroespacial. Con este método innovador de producción se pueden crear los chasis de los asientos de fibra de vidrio más ligeros y resistentes actualmente en comercio; garantiza una reducción del peso total el 30% con respecto a los métodos productivos más tradicionales, estableciendo nuevos estándares de calidad, prestaciones y comodidad del producto.



VACUUM TECH

ULTRA LIGHT-WEIGHT

PROVIDE THE BEST FITTING

NEW

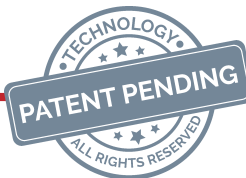

# QRT-R / QRT-R SKY



MANUFACTURER: SPARCO  
MODEL: QRT-R  
HOM. NO: CS.397.18  
FIA STANDARD: 8855-1999

Homologation: FIA 8862-2009

CARBON

QRT-R € 635,00  
QRT-R SKY € 655,00

Progettato con l'utilizzo dei più innovativi software CAD il QRT-R è un sedile di nuovissima concezione. La scocca è stata progettata per essere installata anche negli abitacoli più angusti, il design aggressivo enfatizza la natura corsaia del sedile ed aumenta la rigidità strutturale. Nuovo cuscino diviso in 2 parti e nuovi ricami, due configurazioni previste: sellatura in tessuto oppure in sky. Fissaggio attacchi laterali con interasse da 290 mm.

Designed using the most innovative CAD software available, the QRT-R seat is built around a brand new concept. The frame has been designed to be installed even in the narrowest car interiors, and its aggressive design emphasizes the seat's racing pedigree and increases its structural rigidity. It has a new cushion divided into 2 parts and new stitching, in two configurations: saddling in fabric or sky. Fixed using lateral fastenings with 290 mm spacing.

Diseñado utilizando los software CAD más innovadores, el QRT-R es un nuevo concepto de asiento. La estructura ha sido diseñada para poder instalarla incluso en los habitáculos más estrechos, el diseño agresivo destaca el carácter deportivo del asiento y aumenta la rigidez estructural. Nuevo cojín dividido en 2 partes y nuevos bordados, dos configuraciones previstas: revestimiento en tejido o bien en sky. Fijación con enganches laterales con una distancia entre ejes de 290 mm.

**PESO - WEIGHT (g)**  
**SCocca-SHELL-ESTRUTURA**  
QRT-R: 5900  
QRT-R SKY: 5900  
**SEDILE-SEAT-ASIENTO**  
QRT-R: 7100  
QRT-R SKY: 8000

QRT-R - QRT-R SKY

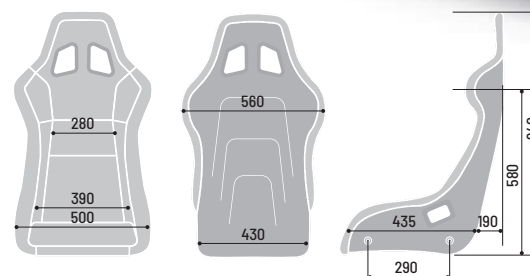

QRT-R SKY



MANUFACTURER: SPARCO  
MODEL: QRT-R  
HOM. NO: CS.397.18  
FIA STANDARD: 8855-1999



QRT-R

008012RNR

008012RNRSKY

NEW

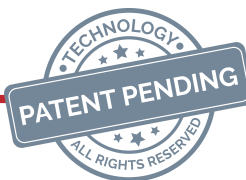

# EVO QRT / EVO II QRT



MANUFACTURER: SPARCO  
MODEL: EVO QRT  
HOM. NO: CS.373.17  
FIA STANDARD: 8855-1999

Homologation: FIA 8855-1999

QRT FIBERGLASS

EVO QRT € 455,00  
EVO II QRT € 495,00

Aggiornato con la nuova tecnologia QRT, il sedile EVO, disponibile in 2 taglie (Evo II taglia L), ha tessuto antiscivolo per contenimento spalle e seduta, nuovo cuscino diviso in 2 parti e nuovi ricami. Nuovo contenimento spalle (solo per EVO) per installazione su vetture di dimensioni contenute. Fissaggio attacchi laterali con interasse da 290 mm.

Updated with new QRT technology, the EVO seat, available in 2 sizes (Evo II size L), has an anti-slip fabric to restrain the shoulders and seat, a new cushion divided into 2 parts and new stitching. New shoulder restraint (only for EVO) for installation in small vehicles. Fixed using lateral fastenings with 290 mm spacing.

Actualizado con la nueva tecnología QRT, el asiento EVO, disponible en 2 tallas (Evo II talla L), tiene tejido antideslizante para contener los hombros y para el asiento, nuevo cojín dividido en 2 partes y nuevos bordados. Nueva parte para contener los hombros (solo para EVO) para instalación en coches con escaso espacio disponible. Fijación con enganches laterales con una distancia entre ejes de 290 mm.

**PESO - WEIGHT (g)**  
**SCocca-SHELL-ESTRUCTURA**  
EVO QRT: 4900  
EVO II QRT: 5400  
**SEDILE-SEAT-ASIENTO**  
EVO QRT: 7000  
EVO II QRT: 6800

EVO QRT - EVO II QRT

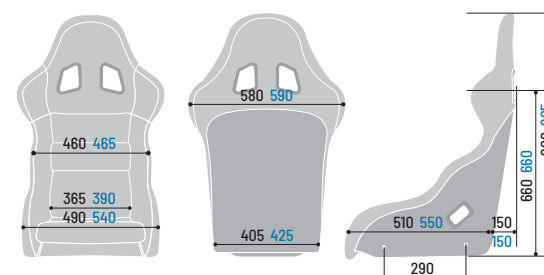

EVO QRT

008007RNR



EVO II QRT



MANUFACTURER: SPARCO  
MODEL: EVO II QRT  
HOM. NO: CS.XXX.2018  
FIA STANDARD: 8855-1999

008008RNR

QRT TECH

NEW

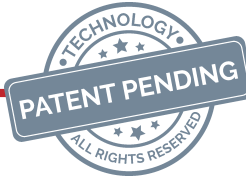

# CIRCUIT QRT / II



MANUFACTURER: SPARCO  
MODEL: CIRCUIT QRT  
HOM. NO: CS.XXX.2018  
FIA STANDARD: 8855-1999

Homologation: FIA 8855-1999

QRT FIBERGLASS

CIRCUIT QRT € 445,00

CIRCUIT II QRT € 475,00

Aggiornato con la nuova tecnologia QRT, il Circuit rimane uno dei sedili più utilizzati in ambito gare Turismo e Rally. Disponibile in 2 taglie (Circuit II taglia L), con sistema DTC integrato, tessuto antiscivolo per contenimento spalle e seduta, nuovo cuscino diviso in 2 parti e nuovi ricami. Fissaggio attacchi laterali con interasse da 290 mm.

Updated with new QRT technology, the Circuit remains one of the most widely-used seats in Touring and Rally car racing. Available in 2 sizes (Circuit II size L) it has an integrated DTC system, non-slip fabric to restrain the shoulders and seat, a new cushion divided into 2 parts and new stitching. Fixed using lateral fastenings with 290 mm spacing.

Actualizado con la nueva tecnología QRT, el Circuit sigue siendo uno de los asientos más utilizados en las carreras de Turismo y Rally. Disponible en 2 tallas (Circuit II talla L), con sistema DTC incorporado, tejido antideslizante para contener los hombros y para el asiento, nuevo cojín dividido en 2 partes y nuevos bordados. Fijación con enganches laterales con una distancia entre ejes de 290 mm.

**PESO - WEIGHT (g)**  
**SCocca-SHELL-ESTRUCTURA**  
CIRCUIT QRT: 7000  
CIRCUIT II QRT: 7100  
**SEDILE-SEAT-ASIENTO**  
CIRCUIT QRT: 8950  
CIRCUIT II QRT: 9100

CIRCUIT QRT - CIRCUIT QRT II

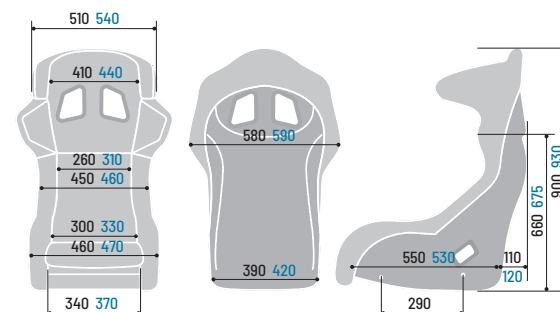

CIRCUIT II QRT



MANUFACTURER: SPARCO  
MODEL: CIRCUIT II QRT  
HOM. NO: CS.XXX.2018  
FIA STANDARD: 8855-1999

008011RNR



CIRCUIT QRT

008010RNR

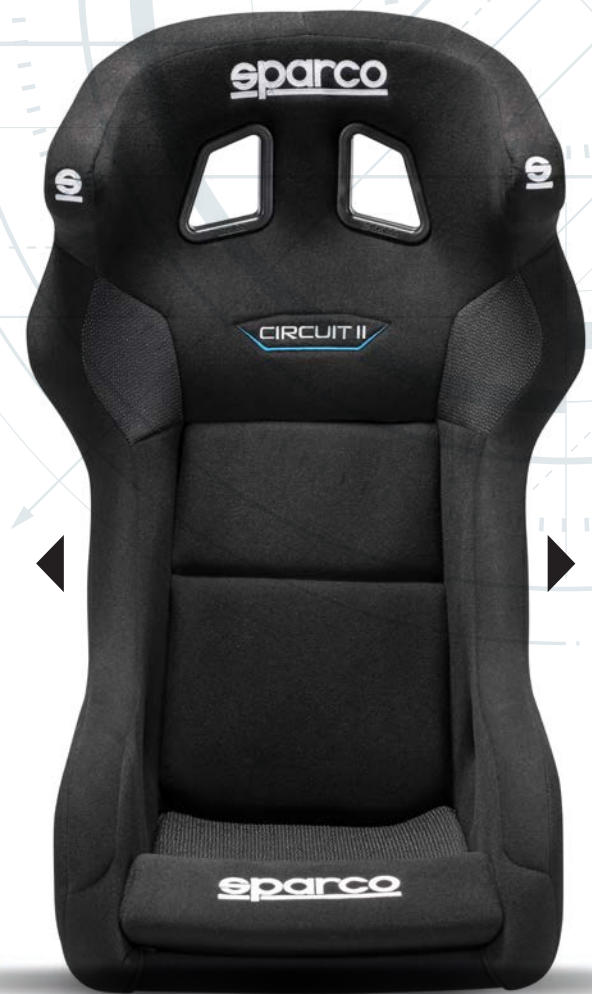

SEATS

151

PREZZI IVA ESCLUSA  
VAT NOT INCLUDED - PRECIOS SIN IVA

RACING

150

# GRID Q

**NEW**

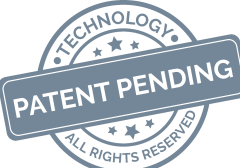

MANUFACTURER: SPARCO  
MODEL: GRID Q  
HOM. NO: CS.xxx.18  
FIA STANDARD: 8855-1999

Homologation: FIA 8855-1999

ORT FIBERGLASS

€ 335,00

Aggiornato con la nuova tecnologia ORT, il sedile GRID Q mantiene la sua caratteristica di elevata mobilità grazie al ridotto ingombro sotto le spalle. Il sedile è composto da PAD imbottiti e personalizzabili, applicati con velcro. Nuovi ricami. Fissaggio attacchi laterali con interasse da 290 mm.

Updated with new ORT technology, the GRID Q seat maintains its high mobility feature due to its reduced bulk under the shoulders. The seat is made up of customisable pads fixed with Velcro. New stitching. Fixed using lateral fastenings with 290 mm spacing.

Actualizado con la nueva tecnología ORT, el asiento GRID Q mantiene su característica de gran movilidad gracias al escaso espacio debajo de los hombros. El asiento se compone de PAD acolchados y personalizables, fijados con velcro. Nuevos bordados. Fijación con enganches laterales con una distancia entre ejes de 290 mm.

PESO - WEIGHT (g)  
SCocca-SHELL-ESTRUCTURA: 5400  
SEDILE-SEAT-ASIENTO: 6800



GRID II QRT

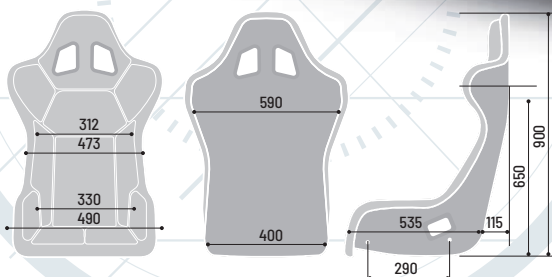

008009RNR

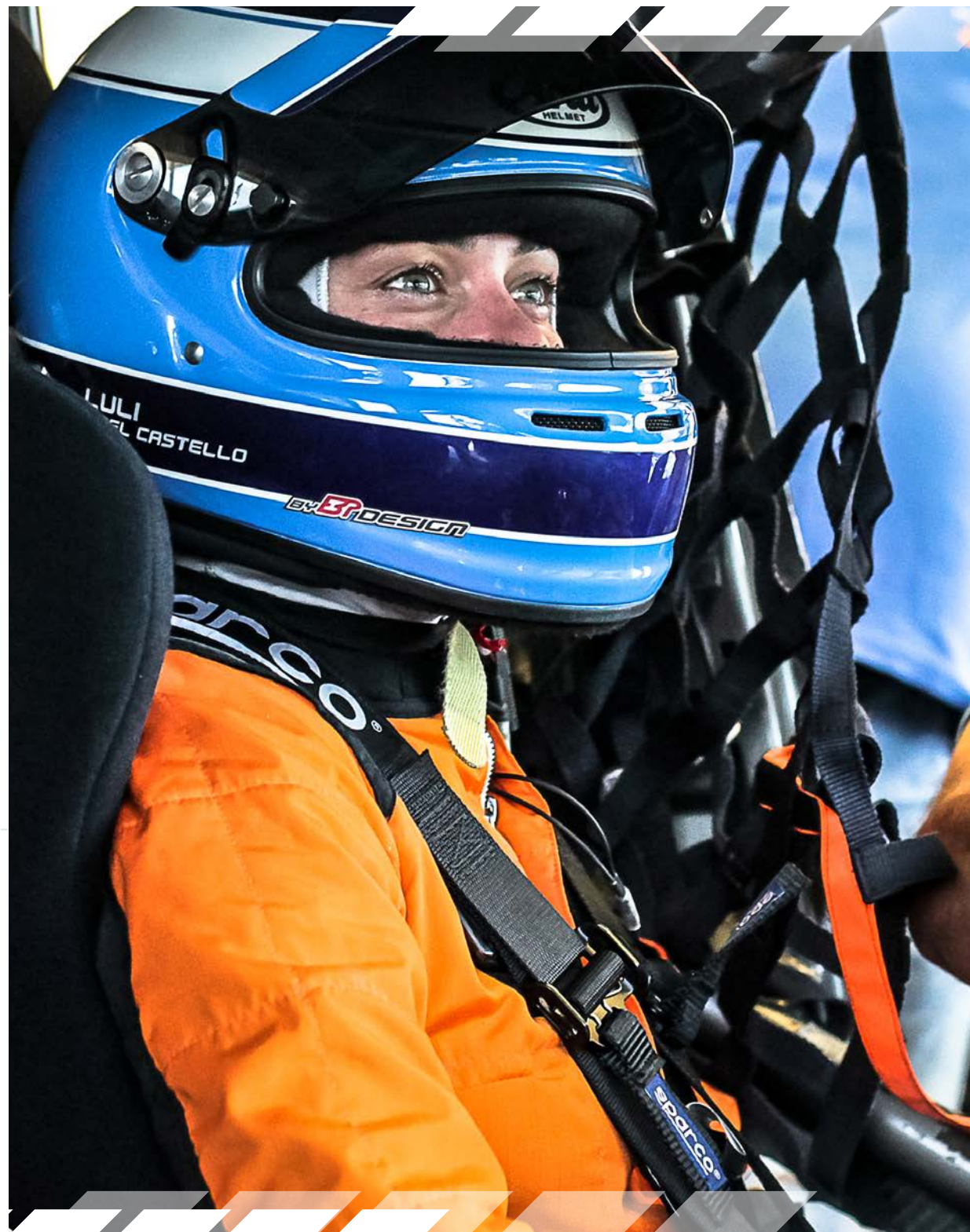

# ERGO LF / LF II

PREZZI IVA ESCLUSA - VAT NOT INCLUDED - PRECIOS SIN IVA



MANUFACTURER: SPARCO  
MODEL: ERGO LF  
HOM. NO: CS.344.16  
FIA STANDARD: 8855-1999

Homologation: FIA 8855-1999

FIBERGLASS

ERGO LF € 555,00  
ERGO LF II € 575,00

Progettato al CAD con l'ausilio di manichini taglie per un perfetto contenimento e migliore funzionalità dei sistemi di sicurezza (cinture e hans). Sistema DTC, contenimento testa rimovibile. Compatibile Hans.  
Disegno innovativo della scocca e materiali speciali permettono un peso inferiore e una più alta rigidità.  
Rivestimento in kinderpoint antiscivolo della seduta e zona spalle per un migliore ancoraggio del pilota.  
Cuscino seduta anatomico e schienale in materiale ad alta traspirabilità per un maggiore comfort. Materiale ad alta resistenza nei punti di maggiore usura.

CAD design ensures perfect fit for drivers, safety harness and HANS device. DTC system, removable head protection. HANS compatible.  
Innovative shell design and use of special materials ensures both lightweight and rigid construction.  
Non-slip Kinderpoint fabric on lower cushion and shoulders for maximum restraint and comfort.  
Anatomic lower cushion and backrest with high breathability fabric for added comfort.  
High resistance material in high wear areas.

Proyectado en CAD con el auxilio de maniquí para una perfecta sujeción y una mejor funcionalidad de los sistemas de seguridad (cinturones y Hans). Sistema DTC sujeción de la cabeza removible. Hans compatible.  
Nueva concepción de la estructura con la utilización de materiales especiales que permiten una reducción del peso y una mayor rigidez.  
Revestido en "Kinderpoint" antideslizante en la parte inferior así como la zona de la espaldas para una mejor sujeción del piloto.  
Cojín asiento anatómico y zona de los hombros en material con características de elevada transpirabilidad para un mayor confort. Material de alta resistencia en los puntos de mayor usura.

**PESO - WEIGHT (g)**  
**SCocca-SHELL-ESTRUCTURA**  
ERGO LF: 9000  
ERGO LF II: 9640  
**SEDILE-SEAT-ASIENTO**  
ERGO LF: 11000  
ERGO LF II: 11600

ERGO LF - ERGO LF II

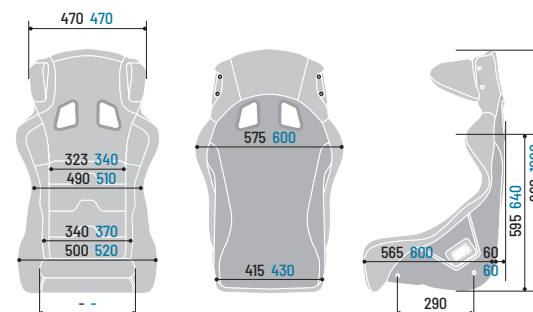

ERGO LF II



MANUFACTURER: SPARCO  
MODEL: ERGO LF  
HOM. NO: CS.344.16  
FIA STANDARD: 8855-1999



Nuovo cuscino seduta cucito in un pezzo unico con lo schienale realizzato con imbottiture ad alto assorbimento, più sottile, leggero e confortevole (disponibile anche come optional). 2 taglie S/M e L.

New lower cushion sewed in one piece with backrest, made with impact absorbent padding, thinner, lighter, more comfortable (available also as an optional). 2 sizes S/M and L.

Nuevo cojín de asiento cosido en una pieza única con el acolchado de respaldo de alta absorción, más delgado, ligero y cómodo (también disponible como opción). 2 tallas S/M y L.

ERGO LF

008722NR2M



SEATS

155

008722NR3L

RACING

154

# PRO-ADV TS

PREZZI IVA ESCLUSA - VAT NOT INCLUDED - PRECIOS SIN IVA



MANUFACTURER: SPARCO  
MODEL: PRO ADV TS  
HOM. NO: CS.298.13  
FIA STANDARD: 8855-1999

Homologation: FIA 8855-1999

FIBERGLASS

€ 545,00



Larghezza max DTC 400 mm, installazione in vettura facilitata anche per abitacoli di piccole dimensioni.  
Contenimento testa rivisto per un migliore appoggio in curva con conseguente riduzione affaticamento muscoli collo.  
Contenimento spalle e gambe per migliorare l'ergonomia. Seduta progettata con inclinazione ottimale per migliorare la posizione di guida.  
V foro di grandi dimensioni per consentire il passaggio della fibbia delle cinture per evitare di togliere il cosciale per smontare il sedile. Peso quasi 2 kg inferiore al Pro-Adv standard.

The DTC is 400 mm to improve mounting options in smaller cockpits.  
Head restraint reviewed to help support driver when cornering resulting in less fatigue on the neck  
Shoulder and leg restraints to improve ergonomics. Ergonomic cushion.  
Bigger hole for the 5th seat belt strap to avoid having to disassemble the lap strap to remove the seat.  
Weight: 2 kg less than standard Pro-Adv

El DTC con ancho maximo de 400 mm, facil instalaci3n tambien en coches pequenos.  
Contenci3n de la cabeza modificada para ayudar el apoyo del piloto y para reducir el cansancio de la musculaci3n del cuello.  
Contenci3n de las espaldas y de las piernas para mejorar la ergonomia.  
Mejor postura de conduccion.  
Quinto punto mas ancho.  
Peso alrededor de 2 kg, inferior al Pro-Adv standard.

PESO - WEIGHT (g)  
SCocca-SHELL-ESTRUCTURA: 7460  
SEDILE-SEAT-ASIENTo: 9200

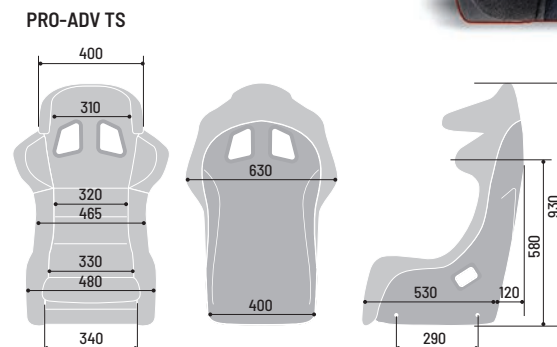

008094FNR



FIBERGLASS

# PRO-ADV LF



MANUFACTURER: SPARCO  
MODEL: PRO ADV LF  
HOM. NO: CS.353.17  
FIA STANDARD: 8855-1999

Homologation: FIA 8855-1999

FIBERGLASS

€ 525,00

Versione in vetroresina  
del PRO-ADV

PRO-ADV fiberglass version

Versión en fibra de vidrio  
del PRO-ADV

PESO - WEIGHT (g)  
SCocca-SHELL-ESTRUCTURA: 10080  
SEDILE-SEAT-ASIENTO: 11600



PRO-ADV LF

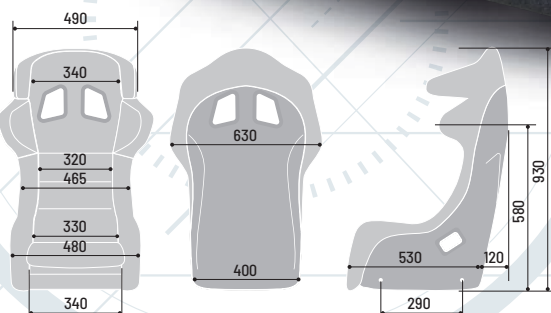

008093FNR

FIBERGLASS

# PRO 2000 LF / LF II



MANUFACTURER: SPARCO  
MODEL: PRO 2000 LF  
HOM. NO: CS.322.15  
FIA STANDARD: 8855-1999

Homologation: FIA 8855-1999

FIBERGLASS

PRO 2000 LF € 485,00

PRO 2000 LF II € 515,00

Tessuto antiscivolo per spalle e seduta.  
Schiennialino integrato da due poggiatesti  
laterali e cuscino a spessore ridotto. Fis-  
saggio attacchi laterali interasse 290 mm.  
Fissaggio inferiori direttamente sulle basi.  
Pro 2000 LF: per piloti di taglia M.  
Pro 2000 LF II: per piloti di taglia L.

No-slip fabric for shoulders and cushion.  
Backrest with 2 lumbar supports and a slim  
cushion design. Lateral fixing (290 mm).  
Lower fixing available.  
Pro 2000 LF: for M size drivers.  
Pro 2000 LF II: for L size drivers.

Tejido antideslizante para hombros y  
asiento. Respaldo con dos contenciones  
lumbares y cojín más delgado. Fijación la-  
teral 290 mm.  
Montaje directamente sobre la base.  
Pro 2000 LF: para pilotos talla M.  
Pro 2000 LF II: para pilotos talla L.

PESO - WEIGHT (g)  
SCocca-SHELL-ESTRUCTURA  
PRO 2000 LF: 7220  
PRO 2000 LF II: 6720  
SEDILE-SEAT-ASIENTO  
PRO 2000 LF: 9100  
PRO 2000 LF II: 8900



PRO 2000 LF

008083FNR

PRO 2000 LF - PRO 2000 LF II

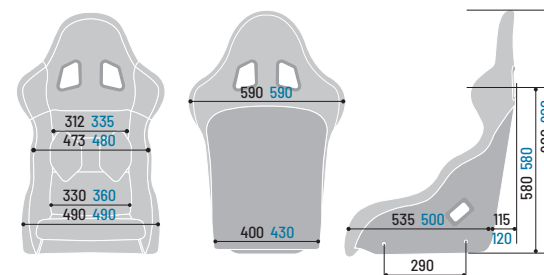

PRO 2000 LF II



MANUFACTURER: SPARCO  
MODEL: PRO 2000 II  
HOM. NO: CS.304.14  
FIA STANDARD: 8855-1999

008273FNR

SEATS

159

PREZZI IVA ESCLUSA - PRECIOS SIN IVA

PREZZI IVA ESCLUSA - PRECIOS SIN IVA

RACING

158

FIBERGLASS

# REV / REV II



MANUFACTURER: SPARCO  
MODEL: REV LF  
HOM. NO: CS.339.16  
FIA STANDARD: 8855-1999

Homologation: FIA 8855-1999

FIBERGLASS

REV € 315,00

REV II € 335,00

Sedile monoscocca in fibra di vetro. Fissaggi laterali con interasse 290 mm. Tessuto ultrasensibile con rinforzi antistrappo nelle zone di maggior usura. Nuovo cuscino più basso per avere una maggiore sensibilità e sicurezza durante la guida. NUOVA TAGLIA XL - Nonostante la taglia sia una XL, le dimensioni esterne del sedile sono contenute e lo rendono ideale per l'utilizzo su piccole vetture da competizione.

Fibreglass monocoque seat. Lateral fixings 290 mm apart. Ultra-resistant cover with tear proof reinforcements in areas most affected by wear. New lower seat cushion for better sensitivity at the wheel. NEW XL SIZE - Despite the XL size, the outer dimensions of the seat are compact making it ideal for use in small competition cars.

Asiento monocasco de fibra de vidrio. Fijaciones laterales con distancia entre ejes de 290 mm. Tejido ultrarresistente con refuerzos antidesgarro en las zonas mayormente sujetas a desgaste. Nuevo cojín más bajo para tener una mayor sensibilidad y seguridad al conducir. NUEVA TALLA XL - No obstante la talla sea una XL, las medidas externas del asiento son reducidas por lo que es ideal para montarlo en coches pequeños de competición.

PESO - WEIGHT (g)

SCocca-SHELL-ESTRUCTURA

REV: 7620

REV II: 7940

SEDILE-SEAT-ASIENTO

REV: 9000

REV II: 10000



REV

008143FNR

REV - REV II

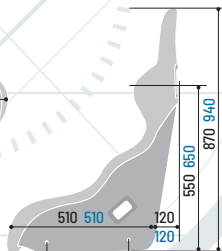
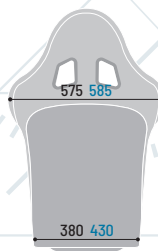
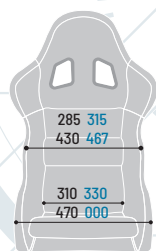

REV II



MANUFACTURER: SPARCO  
MODEL: REV II LF  
HOM. NO: CS.340.16  
FIA STANDARD: 8855-1999

008142FNR



SEATS

161

RACING

160

PREZZI IVA ESCLUSA  
VAT NOT INCLUDED - PRECIOS SIN IVA

TUBULAR

# SPRINT / SPRINT L

**NEW**

**FIA APPROVED**

MANUFACTURER: SPARCO  
MODEL: SPRINT  
HOM. NO: CS.332.15  
FIA STANDARD: 8855-1999

Homologation: FIA 8855-1999

TUBULAR FRAME

SPRINT € 204,00

SPRINT L € 244,00

Interamente rivisto nella sellatura, il sedile Sprint ha un telaio tubolare in acciaio con struttura dello schienale e della seduta ad elastici. Omologato con fori per fissaggio inferiore e laterale e 5 fori passacintura. Gli attacchi laterali hanno interasse di 290 mm.

With completely revised upholstery, the Sprint seat has a tubular steel frame with an elastic backrest and seat structure. Homologated with holes for bottom and lateral fixing and 5 belt holes. The lateral fastenings have 290 mm spacing.

Con revestimiento completamente nuevo, el asiento Sprint tiene un bastidor tubular de acero con estructura del respaldo y del asiento con elásticos. Homologado con orificios para fijación inferior y lateral y 5 orificios por donde hacer pasar el cinturón. Los enganches laterales tienen una distancia entre ejes de 290 mm.

**PESO - WEIGHT (g)**  
**SCocca-SHELL-ESTRUCTURA**  
SPRINT: 7940  
SPRINT L: 10400  
**SEDILE-SEAT-ASIENTO**  
SPRINT: 9000  
SPRINT L: 11000



SPRINT

008235NR 008235RS 008235AZ

SPRINT - SPRINT L

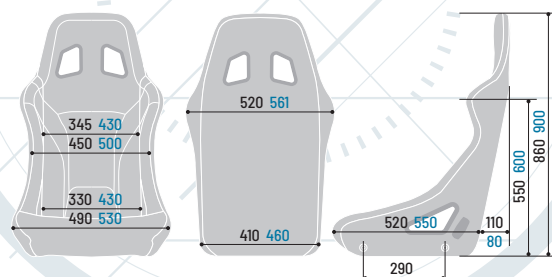

SPRINT L

**FIA APPROVED**

MANUFACTURER: SPARCO  
MODEL: SPRINT L  
HOM. NO: CS.314.14  
FIA STANDARD: 8855-1999

008234LAZ 008234LRS 008234LNR

TUBULAR

# SPRINT SKY

**NEW**

**FIA APPROVED**

MANUFACTURER: SPARCO  
MODEL: SPRINT  
HOM. NO: CS.332.15  
FIA STANDARD: 8855-1999

Homologation: FIA 8855-1999

TUBULAR FRAME

€ 234,00

Interamente rivisto nella sellatura, il sedile Sprint ha un telaio tubolare in acciaio con struttura dello schienale e della seduta ad elastici. Omologato con fori per fissaggio inferiore e laterale e 5 fori passacintura. Ideale per fuoristrada e imbarcazioni. Gli attacchi laterali hanno interasse di 290 mm.

With completely revised upholstery, the Sprint seat has a tubular steel frame with an elastic backrest and seat structure. Homologated with holes for bottom and lateral fixing and 5 belt holes. Ideal for off-road vehicles and boats. The lateral fastenings have 290 mm spacing.

Con revestimiento completamente nuevo, el asiento Sprint tiene un bastidor tubular de acero con estructura del respaldo y del asiento con elásticos. Homologado con orificios para fijación inferior y lateral y 5 orificios por donde hacer pasar el cinturón. Ideal para todoterreno y embarcaciones. Los enganches laterales tienen una distancia entre ejes de 290 mm.

**PESO - WEIGHT (g)**  
**SCocca-SHELL-ESTRUCTURA:** 7940  
**SEDILE-SEAT-ASIENTO:** 9700



SPRINT SKY

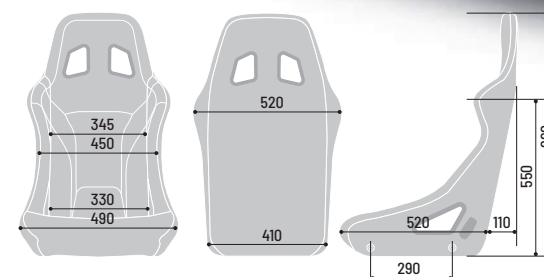

008235NRSKY

SEATS

PREZZI IVA ESCLUSA  
VAT NOT INCLUDED - PRECIOS SIN IVA

RACING

## SUPPORTI A NORME FIA PER SEDILI CON ATTACCHI LATERALI FIA-APPROVED MOUNTING FRAMES FOR SEATS WITH SIDE MOUNTING SOPORTES CONFORME FIA PARA ASIENTOS CON SUJECIONES LATERALES



€ 128,00

Interasse longitudinale 290 mm. 2 pz completamente simmetrici. Lunghezza massima delle basi 415 mm. Facilita di montaggio con piu di 25 posizioni ottenibili. Realizzate in alluminio anodizzato da 6 mm conforme FIA. Kit di montaggio M8 incluso.

Longitudinal distance between holes 290 mm. 2 symmetrical pieces. Max length 415 mm. Simple mounting in the car with more than 25 positions. 6 mm anodized aluminium, FIA compliant. M8 mounting kit included.

Distancia entre ejes longitudinales de 290 mm. 2 Piezas completamente simétricas. Longitud max de 415 mm. Fácil de instalar con más de 25 lugares posibles. Fabricado en aluminio anodizado de 6 mm conforme con la FIA. Kit de montaje M8 incluido.

004903

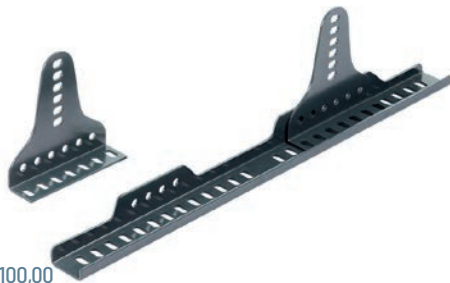

€ 100,00

Base sedile smontabile in acciaio. Max regolazione longitudinale e verticale. Nuovo profilo ad L dell'elemento laterale per una doppia possibilità di bloccaggio sull'elemento di base. Nuovo profilo a C dell'elemento di base per aumentare la resistenza dell'elemento laterale. 22 asole nella base per un'elevata regolazione longitudinale.

Dismountable mounting frame made of Steel. Maximum height and length adjustability. New L shape of the lateral element to allow a double lockage with the base element. New C shape of the base element to increase the grip of the lateral element. 22 eyelets on the base element.

Base asiento desmontable en acero. Ajuste de altura y largo máximos. Nueva forma en L del elemento lateral para permitir un doble bloqueo con el elemento de base. Nueva forma en C en el elemento base para incrementar la adherencia del elemento lateral. 22 ojales en el elemento base.

00492LAT



€ 75,00

Interasse longitudinale 290 mm. 2 pz completamente simmetrici. Lunghezza massima delle basi 400 mm. Facilita di montaggio con piu di 25 posizioni ottenibili. Acciaio verniciato nero a polvere da 3 mm conforme FIA. Kit di montaggio M8 incluso.

Longitudinal distance between holes 290 mm. 2 symmetrical pieces. Max length 400 mm. Simple mounting in the car with more than 25 positions. 3 mm black powder coated, FIA compliant. M8 mounting kit included.

Distancia entre ejes longitudinales de 290 mm. 2 Piezas completamente simétricas. Longitud maxima 400 mm. Fácil de instalar con más de 25 lugares posibles. Fabricado en acero de 3 mm y pintado con polvo negro, conforme con la FIA. Kit de montaje M8 incluido.

004902



€ 45,00

(L max 360 mm) Interasse longitudinale 290 mm. In acciaio da 3 mm di spessore. Longitudinal wheelbase 290 mm. 3mm thick steel. Intereje longit. 290 mm. De acero de 3 mm de grosor.

004901NR

## BASI PER MONTAGGIO SEDILI CON ATTACCO AL FONDO SUBFRAMES FOR BOTTOM MOUNTING. APOYOS PARA MONTAJE DE ASIENTOS CON SUJECIÓN EN EL FONDO.

PER LA LISTA APPLICAZIONI COMPLETA CONSULTARE IL LISTINO  
FOR THE COMPLETE APPLICATION LIST SEE THE PRICE LIST  
PARA VER LA LISTA COMPLETA DE APPLICACIONES ROGAMOS  
CONSULTEN LA TARIFA DE PRECIOS

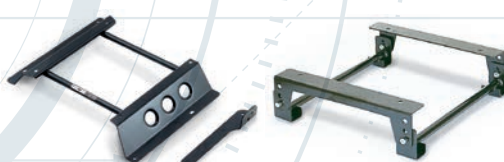

## DRIVER DRINK



01045NR

€ 98,00

Sacca porta borraccia, isola dal calore esterno e mantiene le bevande ad una temperatura costante. Capacità 1,5 litri, bottiglia interna e beccuccio disponibili anche come ricambio. Quattro bretelle per il fissaggio al sedile.

Drink bag. Insulates from outside heat and keeps drinks at a constant temperature. Holds 1,5 litres, inner bottle and spout also available as spare parts. Four braces for attachment to the seat.

Bolso para bota. Aisla del calor exterior y guarda las bebidas a temperatura constante. Capacidad 1,5 litros, botella interior y boquilla disponibles incluso cual repuesto. Cuatro tirantes para la sujeción al asiento.



## IMBOTTITURE OPZIONALI - OPTIONAL PADDING - ACOLCHADOS OPCIONAL



Poggiatesta  
Headrest cushion  
Reposacabezas

01008

€ 29,00



Poggiagambe  
Leg support cushion  
Reposapiés

01011

€ 39,00



Coppia poggiaresi laterali  
Pair of lumbar side backrests  
Par de reposaríones laterales

01022

€ 28,00



Poggiareni universale centrale  
Universal lumbar backrest  
Reposaríones universal central

01023

€ 32,00

## CUSCINO E SCHIENALE - BACKREST AND BASE CUSHIONS - RESPALDO Y FONDO DEL COJÍN



ERGO  
Size: S - M  
Colour: ■

01047KIT872NR1S

€ 130,00



ERGO  
Size: L  
Colour: ■

01047KIT872NR3L

€ 137,00



## CUSCINO OPZIONALE - OPTIONAL CUSHION - COJÍN OPCIONAL

SEAT	mod.	CODE	
ALPHA	A	01048A	€ 89,00
REV II LF	A	01048A	€ 89,00
REV LF	B	01048B	€ 85,00
EVO LF	B	01048B	€ 85,00
EVO II LF	A	01048A	€ 89,00
PRO 2000 LF	A	01048A	€ 89,00





SEAT	mod.	CODE	
PRO 2000 II LF	A	01048A	€ 89,00
CIRCUIT LF	C	01048C	€ 79,00
CIRCUIT II LF	C	01048C	€ 79,00
PRO-ADV LF	A	01048A	€ 89,00
PRO-ADV TS	A	01048A	€ 89,00
PRO-ADV CARB	A	01048A	€ 89,00







RACING

# HARNESSES



ISI<sup>®</sup>

					
	Bouckle w/Tbar	Bouckle w/side fix	Mini tongue + mini Tbar	Mini tongue w/2" adjuster	3" steel adjuster
PRIME H-10					
PRIME H-9			•		
PRIME H-7			•		
04818HAL	•				•
04818RH	•				•
04818HALPD	•				•
04818RAL	•				•
04818RAC	•				•
04818RALPD	•			•	•
04716M1		•			•
04819H		•			•

						
3" aluminium adjuster	2" steel adjuster	Snap on	Bolt on	Carabiner	Roll cage attachment	Dogbone
	•			•	•	
	•			•	•	
		•		•	•	
•		•		•	•	
•		•		•	•	
	•	•		•	•	
	•	•		•	•	
	•	•		•	•	
			•		•	•

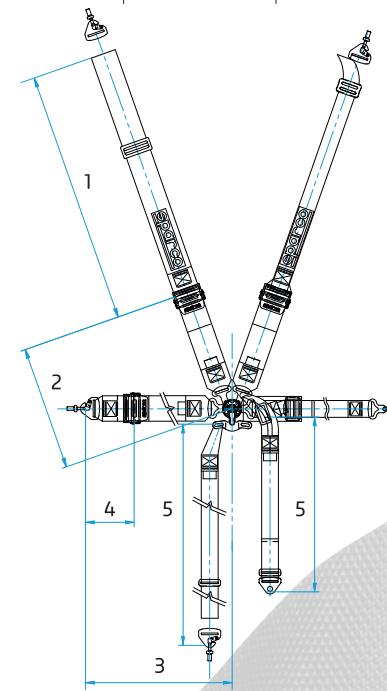

	1	2	3	4	5
	mm				
PRIME H-9	1700	400	700	150	800
PRIME H-7	1700	400	700	150	800
04818HAL	1700	400	700	150	850
04818RH	1700	400	700	150	850
04818HALPD	1700	400	700	150	850
04818RAL	1800	400	700	120	900
04818RAC	1800	400	700	120	900
04818RALPD	1700	400	1000	-	850
04716M	1700	400	800	150	-
04819H	400	350	500	350	700

# PRIME H-10

NEW



Homologation: FIA 8853-2016



MANUFACTURER: SPARCO  
MODEL: 04822H  
HOM. NO: SH.XXX.2018  
FIA STANDARD: 8853-2016

Cintura specifica Hans (tutta da 2"), Regolatori in Titanio, Fibbia full release in Titanio, design Sparco, Fissaggio a dogbone (a vite su richiesta), Nastro ibrido ultraleggero, Peso 500 grammi.

Specific Hans belt (2" suit), titanium adjusters, titanium full-release buckle, Sparco motif, dog-bone fastening (screw fastening on request), ultra-light hybrid ribbon, weight 500 grams.

Cinturón específico Hans (todo de 2"), reguladores de titanio, hebilla Full Release de titanio, diseño Sparco, fijación Dogbone (bajo pedido con tornillo), banda híbrida ultraligera, Peso 500 gramos.

€ ON DEMAND

04822HNR

# PRIME H-7

NEW



Homologation: FIA 8853-2016



MANUFACTURER: SPARCO  
MODEL: 04821H  
HOM. NO: SH.019.17-T-6  
FIA STANDARD: 8853-2016

Cintura specifica Hans (tutta da 2"), Regolatori ultraleggeri in acciaio alto resistenziale, Fibbia in alluminio, Fissaggi: bretelle e cosciali attacco a Rollcage eliminando il moschettone, addominali a carabina per golfare 7/16, Nastro poliestere, Peso Indicativo 1.80 kg.

Specific Hans belt (2" suit), ultralight regulators in high-strength steel, aluminium buckle, fastenings: shoulder and thigh straps with roll cage attachment, abdominals with karabiner for 7/16 eyebolt, polyester ribbon, approximate weight 1.80 kg.

Cinturón específico Hans (todo da 2"), reguladores ultraligeros de acero de alta resistencia, hebilla de aluminio, fijaciones: tirantes y arneses de pierna con fijación Rollcage, abdominales con anillo tipo carabina para anilla 7/16, banda de poliéster, Peso estimadoivo 1,80 kg.

€ 295,00

04821HMNR

04821HMAZ

04821HMRS

# PRIME H-9

NEW



Homologation: FIA 8853-2016



MANUFACTURER: SPARCO  
MODEL: 04820H  
HOM. NO: SH.XXX.2018  
FIA STANDARD: 8853-2016

Cintura specifica Hans (tutta da 2"), regolatori ultraleggeri in acciaio alto resistenziale, fibbia in alluminio, fissaggi: bretelle e cosciali attacco a Rollcage eliminando il moschettone, addominali a carabina per golfare 7/16, nastro ultraleggero in poliestere, Peso indicativo 1.40 kg.

Specific Hans belt (2" suit), ultralight regulators in high-strength steel, aluminium buckle, fastenings: shoulder and thigh straps with roll cage attachment, abdominals with karabiner for 7/16 eyebolt, ultra-light polyester ribbon, approximate weight 1.40 kg.

Cinturón específico Hans (todo da 2"), reguladores ultraligeros de acero de alta resistencia, hebilla de aluminio, fijaciones: tirantes y arneses de pierna con fijación Rollcage, abdominales con anillo tipo carabina para anilla 7/16, banda ultraligera de poliéster, Peso estimadoivo 1,40 kg.

€ 375,00

04820HNR

# 04818RHAL



Homologation: FIA 8853-2016



MANUFACTURER: SPARCO  
MODEL: 04818RH  
HOM. NO: SH.005.16-T-6  
FIA STANDARD: 8853-2016

Bretella specifica Hans (3"- 2")  
Regolatori in alluminio  
Fibbia in alluminio  
Fissaggi a moschettone per tutti i nastri  
Fissaggio a rollbar rimuovendo il moschettone  
fissaggio addominali a carabina per golfare 7/16

Hans specific shoulder strap (3"- 2")  
New aluminium adjusters  
New aluminium buckle  
Carabiner fasteners for all straps  
Fastening to rollbar to remove carabiner fastener

Tirante específico Hans (3"- 2")  
Nuevos reguladores de aluminio  
Nueva hebilla de aluminio  
Fijaciones en mosquetón para todas las bandas  
Fijación en rollbar retirando el mosquetón

€ 350,00

04818RHALNR

04818RHALAZ

04818RHALRS

# 04818RH



Homologation: FIA 8853-2016



MANUFACTURER: SPARCO  
MODEL: 04818RH  
HOM. NO: SH.005.16-T-6  
FIA STANDARD: 8853-2016

Bretella specifica Hans (3"- 2")  
Regolatori in acciaio verniciato  
Fibbia in alluminio  
Fissaggi a carabina per tutti i nastri per golfare 7/16  
Fissaggio a rollbar rimuovendo il moschettone

Hans specific shoulder trap (3"- 2")  
New steel adjusters  
New aluminium buckle  
Carabiner fasteners for all straps  
Fastening to rollbar to remove carabiner fastener

Tirante specifico Hans (3"- 2")  
Nuevos reguladores de acero  
Nueva hebilla de aluminio  
Fijaciones en mosquetón para todas las bandas  
Fijación en rollbar retirando el mosquetón

€ 290,00

04818RHNr

04818RHAz

04818RHrS

# 04818RAL



Homologation: FIA 8853-2016



MANUFACTURER: SPARCO  
MODEL: 04818RAL  
HOM. NO: SH.005.16-T-6  
FIA STANDARD: 8853-2016

Nastri 3"  
Regolatori in alluminio  
Fibbia in alluminio  
Fissaggi a moschettone per tutti i nastri  
Fissaggio a rollbar rimuovendo il moschettone

Straps 3"  
New aluminium adjusters  
New aluminium buckle  
Carabiner fasteners for all straps  
Fastening to rollbar to remove carabiner fastener

Bandas 3"  
Nuevos reguladores de aluminio  
Nueva hebilla de aluminio  
Fijaciones en mosquetón para todas las bandas  
Fijación en rollbar retirando el mosquetón

€ 265,00

04818RALnr

04818RALaz

04818RALrS

# 04818RHALPD



Homologation: FIA 8853-2016



MANUFACTURER: SPARCO  
MODEL: 04818RHALPD  
HOM. NO: SH.005.16-T-6  
FIA STANDARD: 8853-2016

Bretella specifica Hans (3"- 2")  
Regolatori in alluminio  
Fibbia in alluminio  
Fissaggi addominale a carabina per tutti i nastri per golfare 7/16  
Fissaggio a rollbar rimuovendo il moschettone su bretelle e cosciali  
Regolazione addominale PULLDOWN

Straps 3"  
New aluminium adjusters  
New aluminium buckle  
Carabiner fasteners for all straps  
Fastening to rollbar to remove carabiner fastener

Bandas 3"  
Nuevos reguladores de aluminio  
Nueva hebilla de aluminio  
Fijaciones en mosquetón para todas las bandas  
Fijación en rollbar retirando el mosquetón

€ 320,00

04818RHALPDnr

04818RHALPDaz

04818RHALPDrs

# 04818RAC



Homologation: FIA 8853-2016



MANUFACTURER: SPARCO  
MODEL: 04818RAC  
HOM. NO: SH.005.16-T-6  
FIA STANDARD: 8853-2016

Nastri 3"  
Regolatori in acciaio verniciato  
Fibbia in alluminio  
Fissaggi a moschettone per tutti i nastri  
Fissaggio a rollbar rimuovendo il moschettone

Straps 3"  
New steel adjusters  
New aluminium buckle  
Carabiner fasteners for all straps  
Fastening to rollbar to remove carabiner fastener

Bandas 3"  
Nuevos reguladores de acero  
Nueva hebilla de aluminio  
Fijaciones en mosquetón para todas las bandas  
Fijación en rollbar retirando el mosquetón

€ 225,00

04818RACnr

04818RACaz

04818RACrs

PREZZI IVA ESCLUSA  
VAT NOT INCLUDED - PRECIOS SIN IVA

HARNESSES

173

PREZZI IVA ESCLUSA  
VAT NOT INCLUDED - PRECIOS SIN IVA

RACING

172



# 04818RALPD

Homologation: FIA 8853-2016



MANUFACTURER: SPARCO  
MODEL: 04818RH  
HOM. NO: SH.005.16-T-6  
FIA STANDARD: 8853-2016

Cintura a 6 punti di fissaggio tutta da 2" specifica per sistemi FHR e HANS Device  
Fissaggio a moschettone  
Regolazione addominale tipo Pulldown in prossimità della fibbia  
Fissaggio a rollbar rimuovendo il moschettone

Six-point safety harness with 3"+2" shoulder straps for FHR and HANS Device systems  
Carabiner fasteners Abdominal pulldown adjustment near buckle Fastening to rollbar to remove carabiner fastener

Cinturón con 6 puntos de fijación con tirantes de 3"+2" específico para sistemas FHR y HANS Device  
Fijación en mosquetón  
Regulación abdominal tipo Pulldown en proximidad a la hebilla  
Fijación en rollbar retirando el mosquetón

€ 195,00

04818RALPDNR

04818RALPDZ

04818RALPDRS

# 04819H1

Homologation: FIA 8853-2016



MANUFACTURER: SPARCO  
MODEL: 04819H  
HOM. NO: SH.017.17-T-6  
FIA STANDARD: 8853-2016

Cintura a 6 punti Formula nastri tutti da 2" specifica HANS  
fibbia in alluminio  
Regolatori in acciaio  
Fissaggio a Vite 7/16 su addominali  
fissaggio a DOGBONE su bretelle  
fissaggio a rollcage o piattina su cosciale.  
Altri fissaggi su richiesta.

Ultra-light adjusters in high-strength steel, aluminium buckle, screw fastenings to chassis, polyester ribbon.

Reguladores ultraligeros de acero de alta resistencia, hebilla de aluminio, fijaciones al bastidor por medio de tornillos, banda de poliéster.

€ 195,00

04819HNR

04819HAZ

04819HRS

# 04716M1

NEW

Homologation: FIA 8854-1998



MANUFACTURER: SPARCO  
MODEL: 04716M  
HOM. NO: B-345.T98  
FIA STANDARD: 8854-1998

Cintura a 4 punti, Regolatori ultraleggeri in acciaio alto resistenziale, Fibbia in alluminio, Fissaggi a moschettone, Nastro poliestere.

Ultra-light adjusters in high-strength steel, aluminium buckle, snap-hook fastenings, polyester ribbon.

Reguladores ultraligeros de acero de alta resistencia, hebilla de aluminio, fijaciones con mosquetón, banda de poliéster.

€ 195,00

04716M1NR

04716M1AZ

04716M1RS

# 04806SFI

Homologation: SFI

Cintura a 5 punti con fibbia a Latch-n-link omologata SFI.  
Tre colori disponibili.  
Ideale per fuoristrada e/o imbarcazioni.

Three colour available. SFI seat belt, aluminum buckle  
Ideal for off road and boats. 5 fixing point carabiner

Tres nuevos colores disponibles. Cinturón con hebilla de aluminio aprobado SFI. Ideal para coches de off-road. Mosquetón de 5 puntos de fijación.

€ 110,00



04806SFIVDM

04806SFINR

04806SFIVD

PREZZI IVA ESCLUSA  
VAT NOT INCLUDED - PRECIOS SIN IVA

RACING

## CUSCINETTI CINTURE - PAIRS OF SHOULDER PADS ACOLCHADOS PARA CINTURON

Coppia di cuscini cinture da 3" in vellutino imbottito.  
NON IGNIFUGHI.  
Pair of pads for 3" harnesses. Made of padded velour.  
NOT FIREPROOF.  
Par de almohadillas para cinturones de 3". Terciopelo mullido.  
NO IGNIFUGAS.

€ 18,00



01098S3R

01098S3A

01098S3N

€ 3,00



04502

€ 3,50



04501

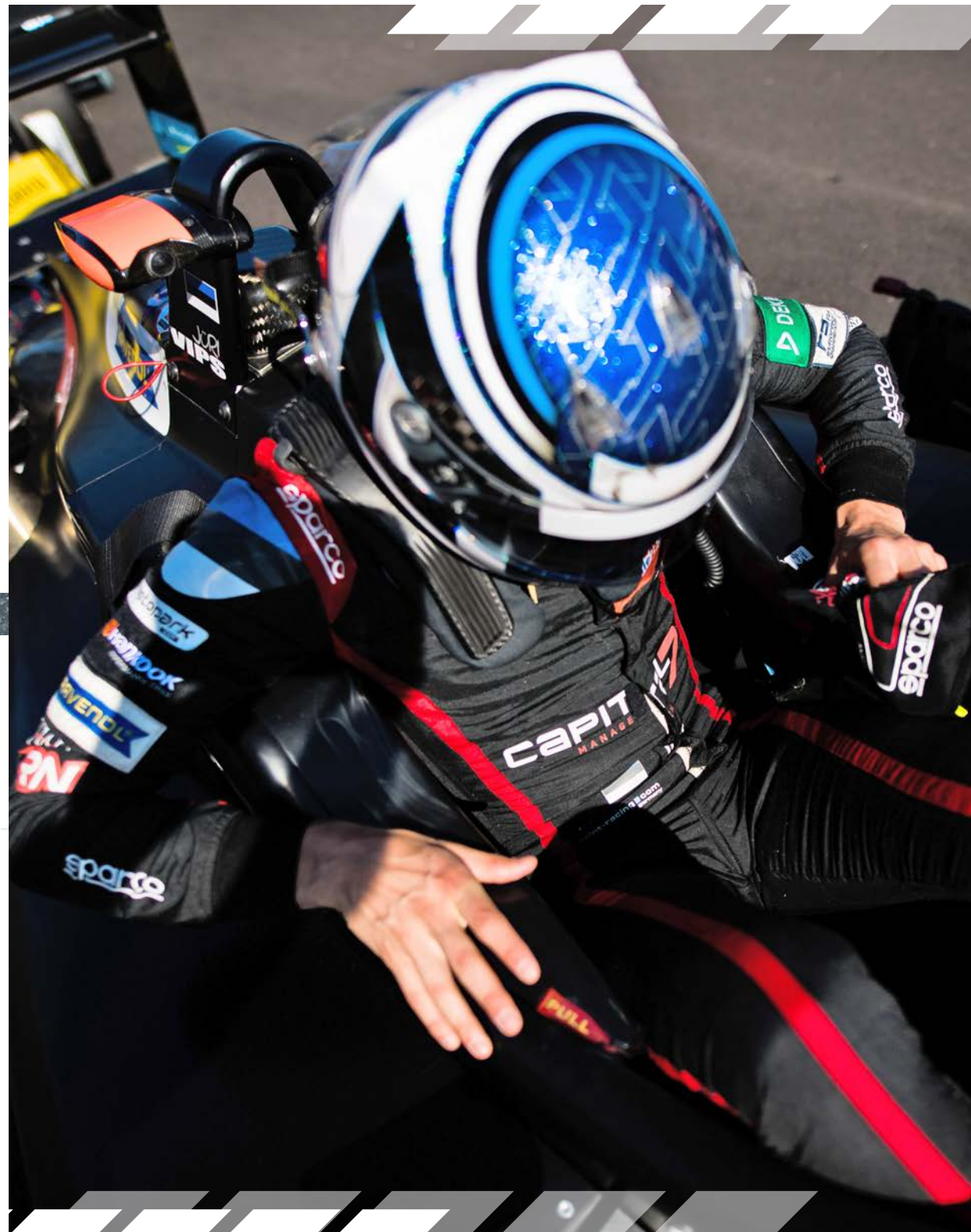

HARNESSES

177

176

RACING

# STEERING WHEELS



ISI<sup>®</sup>

# F-10C

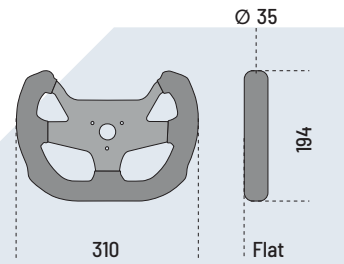

Volante in carbonio per monoposto e sport prototipi. Impugnatura ergonomica, derivata dall'esperienza acquisita con i reparti corse delle più prestigiose case automobilistiche. Interasse Foratura 3x50,8 mm.

Carbon steering wheel for prototype single-seater and sports vehicle. Ergonomic grip, designed based on experience gained with the racing teams of the most prestigious motor manufacturers. Hole interaxis 3x50,8 mm.

Volante de carbono para monoplaça y sport prototipo. Agarre ergonómico, derivada de la experiencia obtenida con los departamentos de carreras de las casas automovilísticas más prestigiosas. Distancia entre agujeros 3x50,8 mm.

Scamosciato - Suede - Ante € 325,00

015PC270SSN

# P310

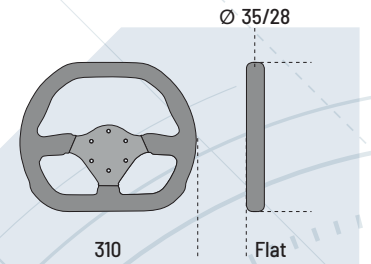

Parte superiore piatta, ideale per vetture Sport. Interasse foratura: 6x70 mm.

Flat steering wheel ideal for Sports car. Hole interaxis: 6x70 mm.

Volante plano ideal para coches de deporte. Distancia entre agujeros: 6x70 mm.

Scamosciato - Suede - Ante € 200,00

015P310F2SN

# F-10A

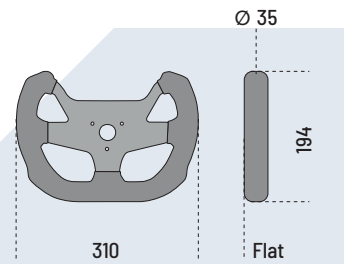

Volante in alluminio per monoposto e sport prototipi. Impugnatura ergonomica, derivata dall'esperienza acquisita con i reparti corse delle più prestigiose case automobilistiche. Interasse Foratura 3x50,8 mm.

Aluminium steering wheel for prototype single-seater and sports vehicle. Ergonomic grip, designed based on experience gained with the racing teams of the most prestigious motor manufacturers. Hole interaxis 3x50,8 mm.

Volante de aluminio para monoplaça y sport prototipo. Agarre ergonómico, derivada de la experiencia obtenida con los departamentos de carreras de las casas automovilísticas más prestigiosas. Distancia entre agujeros 3x50,8 mm.

Scamosciato - Suede - Ante € 195,00

015P270SSN

# P300

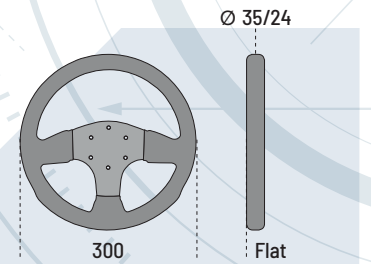

Volante piatto con impugnatura piccola. Interasse foratura: 6x70 mm.

Flat steering wheel with small grip. Hole interaxis: 6x70 mm.

Volante con empuñadura pequeña. Distancia entre agujeros: 6x70 mm.

Scamosciato - Suede - Ante € 200,00

015P300SN

PREZZI IVA ESCLUSA  
VAT NOT INCLUDED - PRECIOS SIN IVA

# R353



Ø 35/27

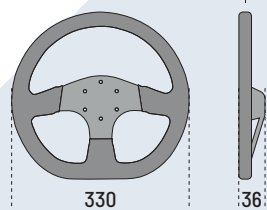

Volante piatto. Impugnatura grossa.  
Interasse foratura: 6x70 mm.

Flat steering wheel with large grip.  
Hole interaxis: 6x70 mm.

Volante plano con empuñadura grande.  
Distancia entre agujeros: 6x70 mm.

Scamosciato - Suede - Ante € 199,00

015R353PSN

# R323



Ø 30/30

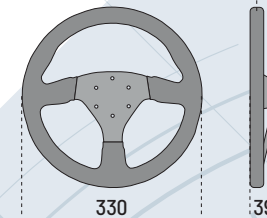

Volante a calice con impugnatura piccola.  
Interasse foratura: 6x70 mm.

Dished steering wheel with small grip.  
Hole interaxis: 6x70 mm.

Volante en forma de copa con empuñadura pequeña.  
Distancia entre agujeros: 6x70 mm.

Scamosciato - Suede - Ante € 199,00

015R323PSNR

PREZZI IVA ESCLUSA  
VAT NOT INCLUDED - PRECIOS SIN IVA

STEERING WHEELS

RACING

# R368



Ø 32/30

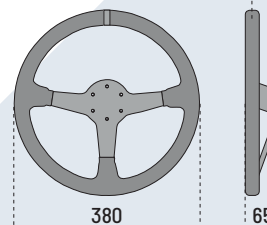

**SPECIFICO PER FUORISTRADA  
OFF ROAD SPECIAL DISHED  
VOLANTE PARA TODOTERRENO**

Volante a calice ideale per fuoristrada.  
Interasse foratura: 6x70 mm.  
Dished steering wheel. Ideal on off-road cars.  
Hole interaxis: 6x70 mm.  
Diseñado con la profundidad ideal para todoterreno.  
Distancia entre agujeros: 6x70 mm.

Scamosciato - Suede - Ante € 199,00

015R368MSN

# R383



Ø 37/29

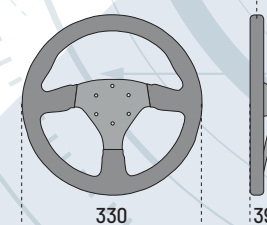

Volante con impugnatura speciale ad alto grip.  
Interasse foratura: 6x70 mm.

Steering wheel with special comfortable grip shape.  
Hole interaxis: 6x70 mm.

Volante con moldeado especial de empuñadura.  
Distancia entre agujeros: 6x70 mm.

Scamosciato - Suede - Ante € 199,00

015R383PSN

182

183

# R375

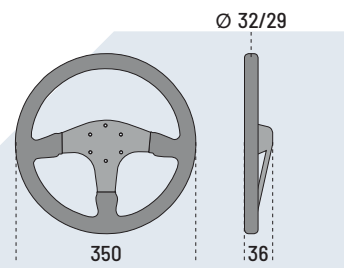

Volante a calice speciale con profondità 36 mm. Interasse foratura: 6x70 mm.

Special 36 mm dished. Hole interaxis: 6x70 mm.

Profundidad especial 36 mm. Distancia entre agujeros: 6x70 mm.

Scamosciato - Suede - Ante € 199,00

015R375PSN

# R215

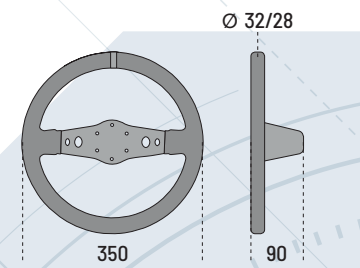

Volante a calice con razze alleggerite. Interasse foratura: 6x70 mm.

Dished steering wheel with lighter spokes. Hole interaxis: 6x70 mm.

Volante en forma de copa con orificios de aligeramiento en los radios. Distancia entre agujeros: 6x70 mm.

Scamosciato - Suede - Ante € 160,00

015R215CSN

# R345

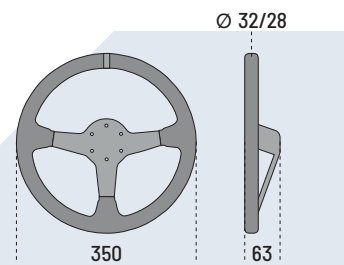

Volante a calice con impugnatura piccola. Interasse foratura: 6x70 mm.

Dished steering wheel with small grip. Hole interaxis: 6x70 mm.

Volante en forma de copa con empuñadura pequeña. Distancia entre agujeros: 6x70 mm.

Scamosciato - Suede - Ante € 160,00

015R345MSN

Pelle liscia - Leather - Piel € 180,00

015R345MLN

# R325

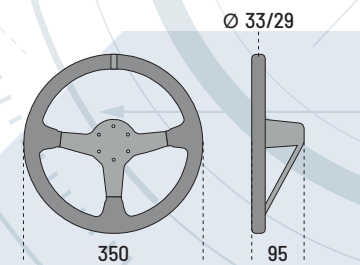

Volante a calice con impugnatura piccola. Interasse foratura: 6x70 mm.

Dished steering wheel with three spokes and small grip. Hole interaxis: 6x70 mm.

Volante en forma de copa de tres radios con empuñadura pequeña. Distancia entre agujeros: 6x70 mm.

Scamosciato - Suede - Ante € 190,00

015R325CSN

# SANREMO

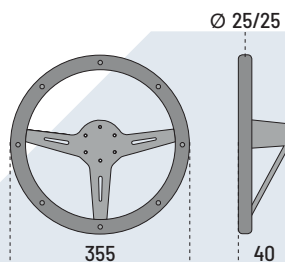

Impugnatura tonda 25/25 mm. Diametro 355 mm. Tre razze lucidate a specchio. Hand grip in mogano naturale verniciato. Fissaggio U-ring alle razze: No. 9 rivetti in alluminio.

Steering wheel with round grip shape 25/25 mm. Diameter 355 mm. Three-spokes mirror polished. Hand grip in natural mahogany painted. U-ring fixing to the spokes: 9 aluminum rivets.

Volante con agarre redondo 25/25 mm. Diametro 355. Tres brazos pulido espejo. "Hand grip" de caoba barnizada. Fijación U-ring en los brazos: 9 remaches de aluminio

€ 240,00

## ACCESSORI • ACCESSORIES • ACCESORIOS

### MOZZI HUB CUBOS PARA VOLANTES

PER LA LISTA APPLICAZIONI CONSULTARE IL LISTINO.  
FOR THE APPLICATION LIST PLEASE CHECK PRICE LIST.  
PARA LA LISTA DE LAS APLICACIONES, CONSULTESE EL LISTÍN.



### QUICK RELEASE TOURING/RALLY



€ 225,00

### QUICK RELEASE TRACK/FORMULA

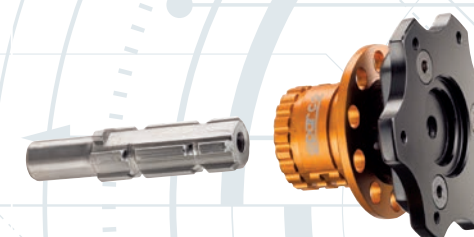

€ 195,00

015R95NR



RACING

# TECHNICAL





# 014774EXN

NEW

FIA APPROVED

MANUFACTURER: SPARCO  
MODEL: 014774EXN  
HOM. NO: XXXX  
FIA STANDARD: 8865-2015

Estintore a doppia camera con serbatoio in acciaio inox, gestione elettronica dell'azionamento  
- agente estinguente Novec + AFFF  
- Sviluppato per vetture GTE - GT3

Double chamber fire extinguisher with stainless steel bottle, electronic actuating control  
- Novec + AFFF extinguishing fluid  
- Developed for GTE - GT3 vehicles

Extintor con doble cámara con depósito de acero inox, control electrónico del accionamiento  
- Agente extintor Novec + AFFF  
- Desarrollado para coches GTE - GT3



014774EXN

€ 1.445,00

# 014772EXL

NEW

FIA APPROVED

MANUFACTURER: SPARCO  
MODEL: SP425  
HOM. NO: EX.052.18  
FIA STANDARD: FIA 2000

Sistema di estinzione ultraleggero ad azionamento elettrico. Serbatoio in acciaio inox certificato CE (testato ad oltre 40 Bar), estinguente AFFF (4.25 litri), ugelli ricavati dal pieno, raccordi totalmente in metallo

Ultra-light, electrically activated extinguisher system. CE certified bottle in stainless steel (tested at over 40 Bar), AFFF foam extinguisher (4.25 litres), solid block-machined nozzles, all-metal connectors

Sistema ultraligero de extinción con accionamiento eléctrico. Depósito de acero inox certificado CE (ensayado para más de 40 bar), extintor AFFF (4,25 litros), boquillas en pieza maciza, racores completamente de metal



014772EXL

€ 599,00



# 014772MSL

**NEW**



MANUFACTURER: SPARCO  
MODEL: SP425  
HOM. NO: EX.052.18  
FIA STANDARD: FIA 2000

Sistema di estinzione ad azionamento meccanico. Serbatoio in acciaio certificato CE (testato ad oltre 40 Bar), estinguente AFFF (4,25 litri), ugelli ricavati dal pieno, raccordi totalmente in metallo

Mechanically activated extinguisher system. CE certified bottle in steel (tested at over 40 Bar), AFFF foam extinguisher (4.25 litres), solid block-machined nozzles, all-metal connectors

Sistema de extinción con accionamiento mecánico. Depósito de acero certificado CE (ensayado para más de 40 bar), extintor AFFF (4,25 litros), boquillas en pieza maciza, racores completamente de metal



014772MSL

€ 220,00

# 014773BXLN2

Estintore approvato FIA ultraleggero - Agente estinguente NOVEC - Capacità 2lt. In accordo con le prescrizioni FIA

FIA-approved ultra-light extinguisher - NOVEC extinguishing fluid - 2 l capacity. Conforms to FIA requirements

Extintor aprobado FIA ultraligero - Agente extintor NOVEC - Capacidad 2lt. Conforme con los requisitos FIA



€ 309,00

014773BXLN2

# 014773BSS2

Estintore a doppia camera con serbatoio in acciaio inox, gestione elettronica dell'azionamento - agente estinguente Novec + AFFF - Sviluppato per vetture WRC - R5 - Cross Country

Double chamber fire extinguisher with stainless steel bottle, electronic actuating control - Novec + AFFF extinguishing fluid - Developed for WRC - R5 - Cross Country vehicles

Extintor con doble cámara con depósito de acero inox, control electrónico del accionamiento - Agente extintor Novec + AFFF - Desarrollado para coches WRC - R5 - Cross Country



€ 75,00

014773BSS2



MA0142013  
MA0142049  
MA01480



MA0142029



MA014RL24CL



MA0142023



MA0142043



MA0142041



MA0142042



MA0142040

# ROLL BAR

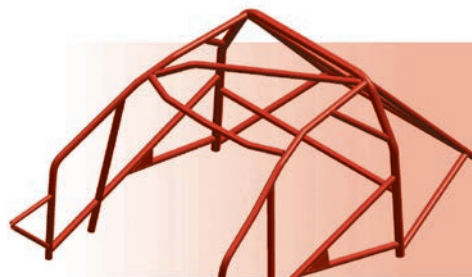

1A-1B

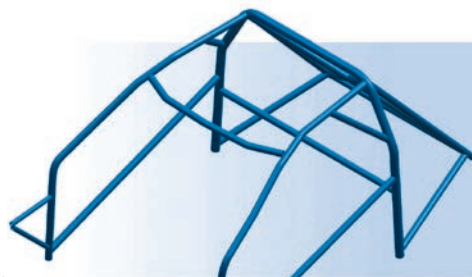

2A-2B

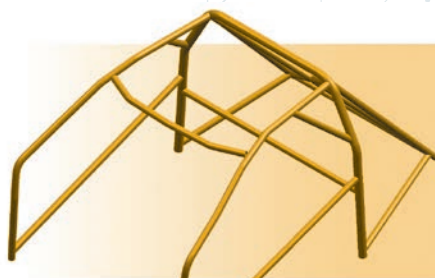

3A-3B-3C



4

## CARATTERISTICHE

Passaggio aderente alla scocca ove possibile. Costruzione accurata. Scatolati di rinforzo specifici. Prodotti con materiale certificato. Ancoraggio sui punti di attacco sospensioni ove possibile.

## FEATURES

Passage adhering to the body shell wherever possible. Accurate manufacturing. Specific boxed reinforcements. Made with certified material. Front suspension fixing points on some models.

## CARACTERÍSTICAS

Paso adherente al bastidor donde es posible. Construcción cuidada. Elementos estructurales huecos de refuerzo específicos. Productos realizados con material certificado. Anclaje en los puntos de unión de las suspensiones donde es posible.

- **1A** Multipunti da saldare con attacco duomi in 25CrMo 4  
Multipoint welded-in, 25CrMo4 with front suspension fixing points.  
Estructura soldada de multipuntos, 25CrMo4 con puntos de fijación a la suspensión delantera.
- **1B** Multipunti da saldare con attacco duomi in Fe 45  
Multipoint welded-in, Fe45 with front suspension fixing points.  
Estructura soldada de multipuntos, Fe45 con puntos de fijación a la suspensión delantera.
- **2A** Multipunti imbullonato, attacco duomi in 25CrMo 4  
Multipoint built-in, 25CrMo4 with front suspension fixing points.  
Estructura atornillada de multipuntos, 25CrMo4 con puntos de fijación a la suspensión delantera.
- **2B** Multipunti imbullonato, con attacco duomi in Fe 45  
Multipoint built-in, Fe45 with front suspension fixing points.  
Estructura atornillada de multipuntos, Fe45 con puntos de fijación a la suspensión delantera.
- **3A** Telaio senza attacco duomi, in 25CrMo 4  
25CrMo4 roll cage without front suspension fixing points.  
Estructura de 25CrMo4 sin puntos de fijación a la suspensión delantera.
- **3B** Telaio senza attacco duomi, in Fe 45  
Fe45 roll cage without front suspension fixing points.  
Estructura de Fe45 sin puntos de fijación a la suspensión delantera.
- **3C** Telaio senza attacco duomi, saldato  
Weld-in roll cage without front suspension point.  
Estructura soldada sin puntos de fijación a la suspensión delantera.
- **4** Gabbia con rinforzi porta in Fe 45  
Roll cages with door bars. Fe 45  
Estructura con tirantes de puertas. Fe 45

PER LA LISTA APPLICAZIONI COMPLETA  
CONSULTARE IL LISTINO  
FOR THE COMPLETE APPLICATION LIST  
PLEASE CHECK PRICE LIST  
PARA LA LISTA COMPLETA DE LAS APLICACIONES  
CONSULTESE EL LISTÍN.

## ROLL BAR PADDINGS

A partire dal 01.01.2003 in tutti i tipi di gara e per tutte le vetture sono diventate obbligatorie le imbottiture roll bar omologate secondo lo standard FIA 8857-2001. Sparco mette a disposizione un materiale omologato secondo la norma FIA 8857-2001 in diverse opzioni per lunghezza e diametro di applicazione. Le imbottiture devono essere applicate al roll bar (montaggio con fascette) in tutte le zone di possibile contatto con il pilota (con cintura di sicurezza allacciata).

As from 01.01.2003 FIA-approved padding has become compulsory in all types of races and cars, Sparco supplies a material certified in accordance with FIA regulation 8857-2001. In different choices of length and diameter. The paddings are fitted to the roll cages in all possible points of contact with driver with harnesses fastened.

A partir del 01.01.2003 revestimiento aprobado por la FIA se ha convertido en obligatorio en todos tipos de carreras y coches, Sparco suministra un material certificado de acuerdo con la reglamentación FIA 8857-2001, con las diferentes opciones de longitud y diámetro. Los revestimientos deben estar instalados en las estructuras en todos los puntos posibles de contacto de los pilotos con los arneses abrochados.

€ 49,00



0076050  
Ø 50 mm - 500 mm - 122 g - Set 2 pcs



0076045  
Ø 45 mm - 500 mm - 131 g - Set 2 pcs



0076040  
Ø 40 mm - 500 mm - 129 g - Set 2 pcs



0076035  
Ø 35 mm - 500 mm - 135 g - Set 2 pcs



## KIT ADEGUAMENTO RACING START RACING START ADAPTATION KIT KIT RACING START

Il kit Racing START viene proposto per l'adeguamento dei roll-bar All.J esistenti alla configurazione obbligatoria per competizioni Racing Start. Il kit è composto da 6 tubi da saldare per la realizzazione dei rinforzi a croce obbligatori su arco principale e tetto, completi di relativi gusset di rinforzo.

Racing start kit is proposed to upgrade the existing Appendix J roll cages. This kit is composed of 6 tubes to build up the cross reinforcement for the roof and the main roll bar, complete with reinforcement gussets.

El kit Racing Start se propone para poner al día el arco en el Anexo J. Este kit se compone de seis tubos a soldar para la realización de los tirantes diagonales para el arco principal y los refuerzos del techo, completado con las relativas cartelas de refuerzo.

€ 149,00

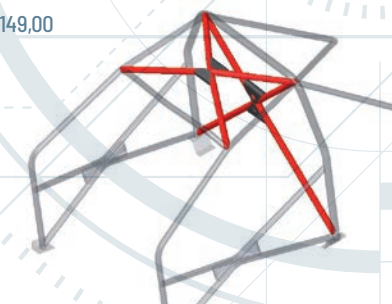

00780KS

## KIT BARRE PORTA - DOOR BARS KIT KIT DE TIRANTES DE PUERTAS

Kit universale composto da 2 barre porta (diam. 40x2 mm) con spinotti saldati su un lato, 4 viti M10, 4 dadi autobloccanti M10, 4 forcelle, 2 spinotti.

Universal kit composed of 2 x door bars (diam. 40 x 2 mm) with 2 x welded plugs on one side, 4 x M10 screws, 4 x M10 self-locking bolts, 4 x forks, 2 x plugs.

Kit universal compuesto de 2 tirantes de puerta (diam. 40 x 2 mm) y 2 manguitos soldados, por lado, 4 tornillos M10, 4 tuercas autobloccantes M10, 4 chapas curvadas en U, 2 manguitos.

€ 110,00

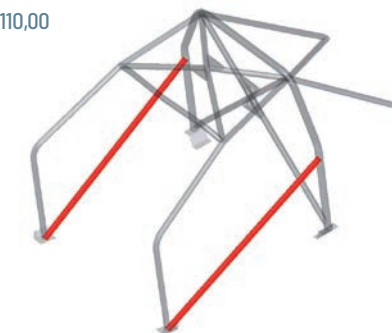

00797

**KIT GUSSET UNIVERSALE PER CROCE ARCO O TETTO**  
**UNIVERSAL GUSSET KIT FOR ROOF**  
**OR MAIN ROLL BAR CROSS REINFORCEMENT**  
**KIT UNIVERSAL DE CARTELAS DE REFUERZO DE TECHO**  
**O DE ARCO PRINCIPAL**

Il kit comprende n° 2 gusset universali di rinforzo per il montaggio sugli incroci dei tubi (dimensioni 190x85 mm). Essendo un prodotto universale potrebbe essere necessario doverlo adattare al proprio rollbar.

kit composed of 2 x universal reinforcement gussets to be mounted on the tubes' cross joint (dimensions 190 x 85 mm). This is a universal kit so it's could be necessary for the user to adapt it to his own roll cage.

kit compuesto por 2 cartelas de refuerzo universales para ser montadas en las intersecciones de los tirantes transversales (dimensiones 190 x 85 mm). Este es un kit universal por lo que podría ser necesario que el usuario lo adapte a su propia estructura.

€ 29,00

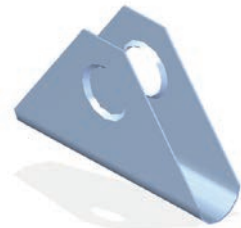

00798SP1

**FORCELLA ROLL BAR - ROLL CAGE FORK**  
**CHAPAS EN "U" PARA ESTRUCTURA**

Forcella per assemblaggio tubi tramite sistema spinotto + forcella. (per tubo Ø 40 mm)(per tubo Ø 50 mm)

fork for tubes' assembly, using plug + fork system (tube diameter 40 mm)(tube diameter 50 mm).

Chapa en "U" para el montaje de tirantes, utilizando manguito + sistema de chapa en "U" (para tubos de diámetro de 40 mm), (para tubos de diámetro de 50 mm).

€ 9,00



Ø 40 mm

Ø 50 mm

0078140S

0078150S

**KIT MANICOTTI - ROLL CAGE PLUGS - KIT DE MANGUITOS**

Coppia manicotti forati (diametro 45 mm) per assemblaggio tubi. Pair of perforated sleeves (diameter 45 mm) for tubes' assembly. Manguitos perforados para el montaje de los tubos (Ø 45 mm).

€ 25,00



00780M

**KIT GUSSET UNIVERSALE PER CROCE BARRE PORTA**  
**UNIVERSAL GUSSET KIT FOR DOORBAR CROSS**  
**KIT UNIVERSAL DE CARTELES PARA TIRANTES DE PUERTA EN "X"**

Il kit comprende n° 4 gusset universali di rinforzo per il montaggio sugli incroci dei tubi (dimensioni 100x170 mm). Essendo un prodotto universale potrebbe essere necessario doverlo adattare al proprio rollbar.

kit composed of 4 x universal reinforcement gussets to be mounted on the tubes' cross joint (dimensions 100 x 170 mm). This is a universal kit so it's could be necessary for the user to adapt it to his own roll cage.

kit compuesto de 4 cartelas de refuerzo universal en las intersecciones de los tirantes (dimensiones 100 x 170 mm). Este es un kit universal por lo que podría ser necesario que el usuario lo adapte a su propia estructura.

€ 39,00

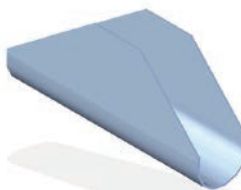

00798SP2

**SPINOTTO ROLL BAR - ROLL CAGE PLUG**  
**MANGUITOS DE ESTRUCTURA**

Spinotto forgiato per assemblaggio tubi tramite sistema spinotto+forcella.

forged plug for tubes' assembly, using plug + fork system. manguitos forjados para el montaje de tirantes, utilizando manguitos + chapas en "U".

€ 9,00



00782NTS

**KIT AGGIORNAMENTO PIASTRE + CONTROPIASTRE FIA 2010**  
**REINFORCEMENT PLATES + COUNTERPLATES FIA 2010**  
**UPDATING KIT**  
**PLACAS DE REFUERZO + CONTRA-PLACAS**  
**DEL KIT DE ACTUALIZACIÓN FIA 2010**

Il kit è composto da n°4 piastre forate + 4 contropiastre piane (spessore 3 mm). Vanno adattate secondo la diversa conformazione del roll bar e della scocca e permettono di aggiornare il fissaggio del roll bar secondo la norma FIA introdotta nel 2010.

kit composed of 4 x perforated plates + 4 x flat counter plates (3 mm thick). These plates must be adapted in accordance to the different configurations of roll cages or body shells and allow to update the roll cage fixing in accordance with 2010 FIA regulation.

kit compuesto de 4 placas perforadas + 4 contra-placas planas (3 mm de espesor). Estas placas deben ser adaptadas en función de las diferentes configuraciones de las estructuras o de las carrocerías y permitir que se actualice la fijación de la estructura, de acuerdo con la reglamentación FIA 2010.

€ 49,00

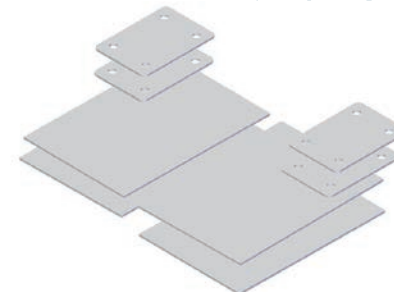

00780P

**SUBARU IMPREZA STI**

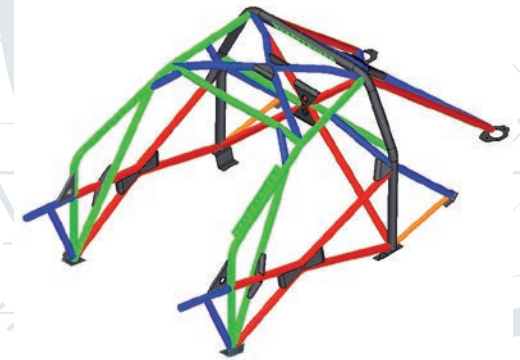

**SEAT LEON CUPRA**

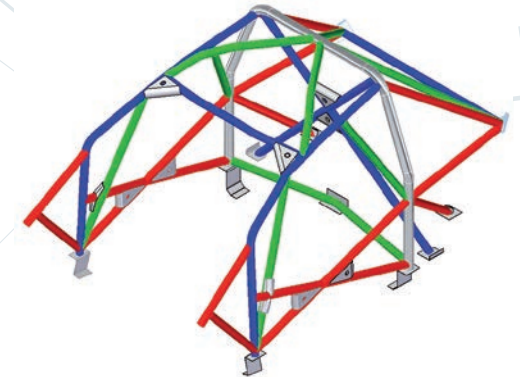

**MITSUBISHI EVO VIII**

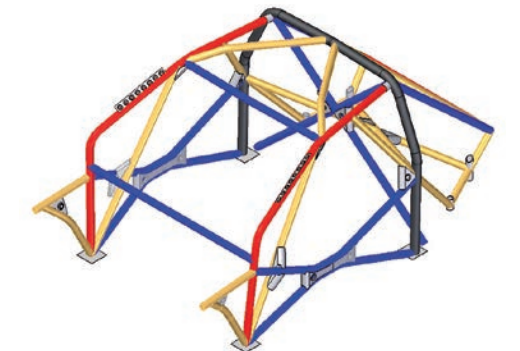

## NAVIGA

Lastra di 5 mm anodizzata argento tagliata al laser. Pre-forata per un rapido fissaggio sull'autoveicolo o sulla pedana MAT, inclinazione regolabile. cm 36 x 28 circa. Made in Italy.

5 mm anodized aluminium sheet, laser cutted. Pre drilled for easy fitting on the floor, or on the MAT floor, adjustable angle; dimensions about cm 36 x 28. High quality materials.

Placa de 5 mm anodizada plata, cortada con láser. Preagujerada para una rápida fijación sobre el vehículo o la plataforma MAT, inclinación regulable. dim. 36 cm. x 28 cm. aproximadamente.

€ 120,00



03789TAN

03789RAN

## MATT

Lastra di 5 mm anodizzata argento tagliata al laser. Pre-forata per un rapido fissaggio sull'autoveicolo. cm 50 x 38 circa.

5 mm anodized aluminium sheet, laser cutted. Pre drilled for easy fitting dimensions about cm 50 x 38. High quality materials.

Placa de 5 mm anodizada plata, cortada con láser. Preagujerada para una rápida fijación sobre el vehículo, dim. 50 cm. x 38 cm. aproximadamente.

€ 120,00

## CO-DRIVER FOOTREST

Supporto pedana collassabile in caso di urto. In alluminio anodizzato mandorlato.

Footrest collapsible in the event of a crash. Embossed anodised aluminium.

Base de la tarima colapsable en caso de choque. De aluminio anodizado embutido.

€ 65,00



03789AN

## DRIVER FOOTRESTS

€ 22,50

Alluminio anodizzato mandorlato, con accessori per il montaggio. Embossed anodised aluminium, with brackets, bolts and screws. De aluminio anodizado embutido, con accesorios para el montaje.

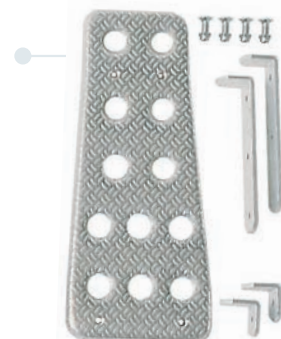

03780AN

€ 32,00

In alluminio anodizzato mandorlato. In embossed anodised aluminium. De aluminio anodizado embutido.



03778AN (until stock last)

€ 43,00

Poggiatesta pilota lucidato. Driver footrest in shiny aluminium. Reposapiés conductor en aluminio brillante.



03788BRI

## PEDALIERE • PEDAL SETS • PEDALES

€ 33,00

Acciaio. Colore nero - Steel. Black - Acero. Color Negro.



03775

€ 23,00

Set 3 pezzi, in alluminio mandorlato, completo di accessori per il montaggio.

3-piece set in embossed anodised aluminium, complete with brackets, bolts and screws.

Juego de 3 piezas, de aluminio embutido, completo de accesorios para el montaje.



03779AN

€ 74,00

Set 3 pezzi, in misto carbonio. Precurvate. Freno e frizione con inserti antiscivolo.

3-piece set in pre-bent and shaped mixed carbon. Brake and clutch with non-slip inserts

Juego de 3 piezas, de mixto carbonio. Curvados previamente. Freno y embrague con aplicaciones antideslizamiento.



03783L

## GANCI COFANO - BONNET PINS CIERRES CAPÓ

**01606S** - Coppia ganci a spillo in acciaio con spina guidata e chiusura a scatto.  
Pair of stainless steel bonnet pins with captive slide pin.

Pareja de cierres capó de punzón, en acero con clavija y cierre de muelle.

**01606A** - Coppia ganci a spillo in alluminio anodizzato blu o rosso con spina guidata e chiusura a scatto.  
Pair of aluminium bonnet pins, anodised blue or red with captive slide pin.

Pareja de cierres capó de punzón, en aluminio anodizado azul o rojo con clavija y cierre de muelle.

**01608** - Coppia ganci a molla in acciaio inossidabile.  
Pair of stainless steel spring hooks.

Pareja de cierres capó de muelle de acero inoxidable

€ 21,50



01606S

01606AA

01606AR

01608

€ 32,00



270050A



27009G

## TAPPI SERBATOIO - AERO FUEL CAPS TAPÓN AERONÁUTICO

Oss. Argento. Silver-Oss. Plata  
Senza chiave. Without key.  
Sin llave.

€ 85,00

## PARASPRUZZI MUD FLAPS CHAPAS

Coppia paraspruzzi sagomati in polietilene da 1,5 mm di spessore. No FIA.

Curved polyethylene mud guards kit thickness 1,5 mm not FIA compliant.

Protección contra salpicaduras moldado en polietileno de 1,5 mm de espesor no conforme con la FIA.

€ 12,50

☐ 03791    ■ 03791RS    ■ 03791AZ    □ 03791NR



**FIA APPROVED**  
Coppia lastre, robustissime  
Pair of red plates, very sturdy.  
Par de chapas muy robustas.  
285 x 500 x 4 mm

€ 100,00

■ 03794RS



**NEW**

## KIT 8 ADESIVI FUSTELLATI KIT OF 8 STICKERS KIT DE 8 ADHESIVOS

€ 2,50

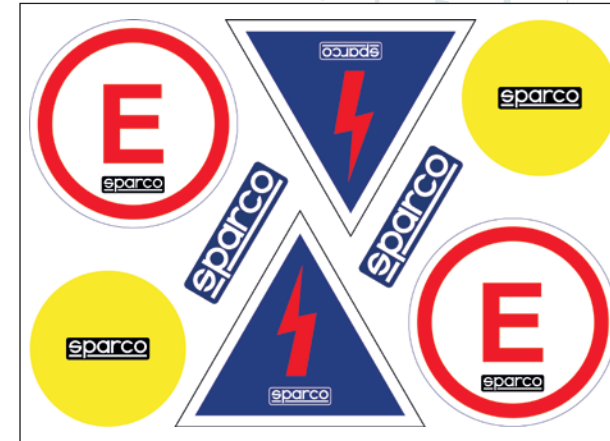

ASPA002

## HAMMERS

Professional hammer with light and seatbelt cutter built-in.

€ 15,00



01615

Hammer with seatbelt cutter built-in.

€ 9,90



01613

## COPERTE TERMICHE TYRE WARMERS MANTAS TÉRMICAS

**NEW**

PER LA LISTA APPLICAZIONI CONSULTARE IL LISTINO.  
FOR THE APPLICATION LIST PLEASE CHECK PRICE LIST.  
PARA LA LISTA DE LAS APLICACIONES,  
CONSULTESE EL LISTIN.



## RETI FINESTRINO WINDOW NETS RED VENTANILLA

Omologate secondo le specifiche FIA.  
Dimensioni: lungh. 50 cm, alt. 52 cm.  
Con nastro in Velcro per fissaggio rapido al roll bar.

Approved in compliance with FIA 2003 spec.  
Dimensions: 50 cm long and 52 cm high.  
Velcro tape for quick fastening to roll bar.

Homologada según las especificaciones FIA 2003.  
Dimensiones: largo 50 cm, alto 52 cm. Con cierre a Velcro  
para una rápida sujeción a la barra de seguridad.

€ 60,00

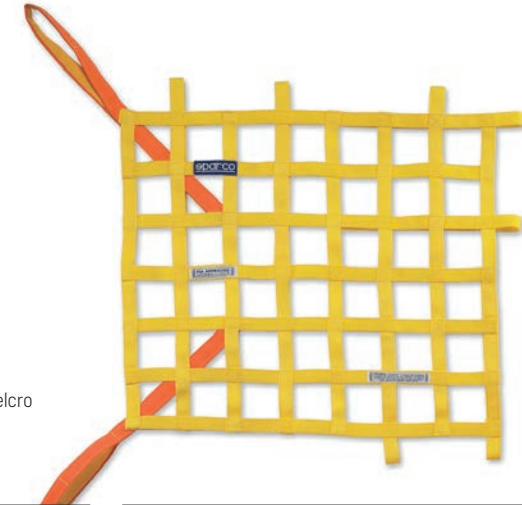

002192FA-R

002192FA-G

002192FA-BM

## RETE FINESTRINO OMOLOGATA FIA 8863-2013 SPECIFICA PER USO PISTA

Fissaggio lato sedile con cinghie da 1" e regolatori a 2 barre per fissaggio a rollbar  
Fissaggio lato cruscotto con possibilità di doppio utilizzo:

- Fissaggio a sgancio rapido con nastro da 1"
- Fissaggio a sgancio rapido con nastro da 2" e regolatore a molle per una migliore messa in tensione della rete.

### FIA 8863-2013 APPROVED WINDOW NET SPECIFICALLY FOR TRACK USE

Seat side fixing with 1" belts and 2 bar adjusters for fixing to rollbar  
Dashboard side fixing with optional double use:

- Quick release fixing with 1" strap
- Quick release fixing 2" strap and spring-operated adjuster for better net tension.

## RED DE SEGURIDAD PARA VENTANILLA HOMOLOGADA FIA 8863-2013 ESPECÍFICA PARA USO PISTA

Fijación en lado asiento con correas de 1" y reguladores de 2 barras para fijación al rollbar

Fijación en lado salpicadero con posibilidad de doble uso:

- Fijación de desenganche rápido con cinta de 1"
- Fijación de desenganche rápido con cinta de 2" y regulador de resortes para mejorar el tensado de la red de seguridad.

€ 210,00

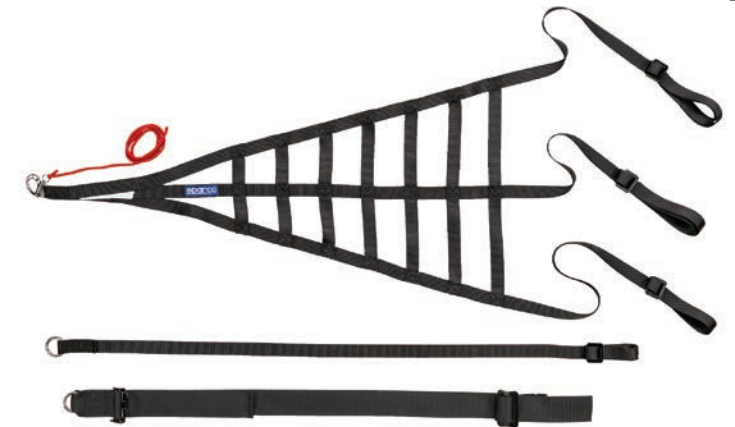

MANUFACTURER: SPARCO  
MODEL: 002193NR  
HOM. NO: RN.008.16  
FIA STANDARD: 8863-2013

002193NR

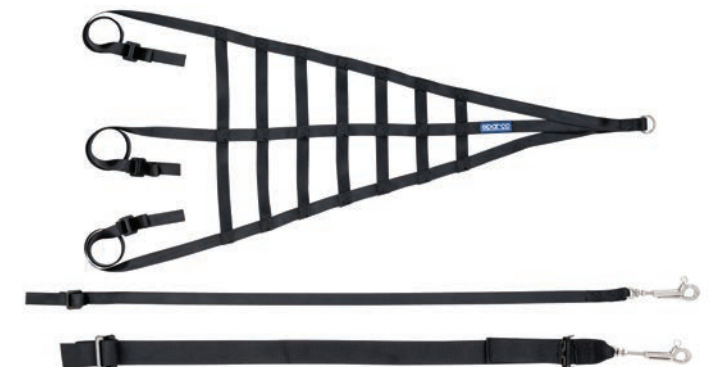

MANUFACTURER: SPARCO  
MODEL: 002194NR  
HOM. NO: RN.011.17  
FIA STANDARD: 8863-2013

002194NR

**TABELLA BOX • PIT SIGNAL BOARD  
CUADRO CAJA**

Telaio in alluminio nero antiriflesso.  
4 row reflection-proof black aluminium frame.  
Bastidor de aluminio barnizado negro antirreflejo.



PIT SIGNAL KIT € 210,00

00594



- |         |             |          |
|---------|-------------|----------|
| 00594C  | Cover       | € 125,00 |
| 00592/1 | Number sets | € 62,00  |
| 00594T  | Pit board   | € 74,00  |

**SC-505**

5 memorie Funzione tempo sul giro o parziale - Precisione di 1/100 sec fino a 24 ore - Conteggio automatico dei giri fino a 99 - Possibilità di memorizzare i tempi dei primi 5 concorrenti - Segnale acustico di conferma dell'azionamento pulsanti.

5 memory lap or split timing modes - 1/100 sec precision for 24 hours - automatic lap counter to 99 1st-5th places - button confirm beep.

Memoria di hasta 5 tiempos Función de tiempo en vuelta o parcial Precisión de 1/100 hasta 24 horas - Contador automático de vueltas hasta 99 - 1º y 5º lugares - Señal sonora de confirmación al pulsar un botón.

€ 62,00



00550003BM

**TEMPO**

Prodotto professionale per uso rally - Cronometro e calcolatrice di tempi - Confronto tempo con quello di 30 concorrenti. Precisione: 0.01 sec. - Funzioni tempo: totale, parziale, countdown con allarme sonoro, classifica - Collegabile a PC per download dati - Peso: 115 g. Dimensioni: 72 x 105 x 26.

Professional product for rally use - Chronometer and time calculator - Comparison of your time and that of 30 competitors. Precision: 0.01 sec - Time functions: total, partial, countdown - with acoustic alarm, classification - PC connection to download data - Weight: 115 g. Dimensions: 72 x 105 x 26.

Producto profesional para uso en rally - Cronómetro y calculadora de tiempos - Comparación de su tiempo con el de otros 30 contrincantes. Precisión: 0,01 s - Funciones de tiempo: total, parcial, cuenta regresiva con alarma sonora, clasificación - Conexión a la PC para descargar datos - Peso: 115 g. Dimensiones: 72 x 105 x 26.

€ 210,00



00557CS03

**LAMPADA LEGGINOTE  
MAPLIGHTS • LÁMPARA DE LECTURA**

Lampada legginote led, lungh. 49 cm, tubo flessibile, 12 V.  
Led Reading lamp, length 49 cm, flexible tube, 12 V.  
Lámpara de lectura, longitud 49 cm, tubo flexible, 12 V.

€ 49,00



01628

**NOTE PAD**

€ 14,50



03724

**MANOMETRI - TYRE PRESSURE GAUGES - MANÓMETROS PRESIÓN PNEUMÁTICOS**

Ø 63 mm

Scala 0 - 4 Bar, manopola in alluminio, calotta in gomma, grande precisione di rilevamento e facilità di lettura.

Scale 0 - 4 bar, aluminium handle, rubber cap, high-precision recording.

Escala 0 - 4 bar, manecilla de aluminio, calotas de goma, gran precisión de detección y facilidad de lectura.

€ 89,00



2941463

Ø 100 mm

Scala 0 - 4 Bar, manopola in alluminio, calotta in gomma, grande precisione di rilevamento e facilità di lettura.

Scale 0 - 4 bar, aluminium handle, rubber cap, high-precision recording.

Escala 0 - 4 bar, manecilla de aluminio, calotas de goma, gran precisión de detección y facilidad de lectura.

€ 129,00



2942410C



## STACCBATERIA A LEVA - BATTERY MASTER SWITCH DESCONECTOR DE BATERÍA CON PALANCA

Staccabatteria esapolare a leva rotante Interruzione immediata di tutti i circuiti elettrici. Predisposto per il comando remoto. Conforme alle specifiche FIA. Idoneo per impianti a 6, 12 e 24V, carico massimo 100A.

Battery master switch with rotating lever. Instant disconnection of all electric circuits. Provision for remote control Complies with FIA spec. Suitable for 6, 12 and 24V systems, rated at 100A continuous.

Interruptor principal de batería con palanca oscilante. Desconexión instantánea de todos los circuitos eléctricos. Provisto con un control remoto Conforme a las especificaciones FIA. Apto para sistemas de 6, 12 y 24V, carga máxima 100A.

€ 39,00



01337

Staccabatteria bipolare a leva rotante Interruzione immediate del circuito elettrico principale. Predisposto per il comando remoto. Idoneo per impianti a 6, 12 e 24V, carico massimo 100A.

Bipolar master battery cutout switch with rotating lever. Instant disconnection of master electric circuit. Provision for remote control. Suitable for 6, 12 and 24V systems, rated at 100A continuous.

Interruptor bipolar principal de batería con palanca oscilante. Desconexión instantánea de los principales circuitos eléctricos. Provisto con un control remoto. Apto para sistemas de 6, 12 y 24V, carga máxima 100A.

€ 17,00



01336

## GANCI TRAINO - TOWING EYE - GANCHO DE REMOLQUE

Gancio traino in acciaio diametro foro 50 mm conforme FIA. Steel towing eye. Hole diameter 50 mm, FIA compliant. Gancho de remolque en acero con agujero de 50 mm conforme con la FIA.

€ 35,00



01626GI

Gancio traino in acciaio diametro foro 80 mm conforme FIA. Steel towing eye. Hole diameter 80 mm, FIA compliant. Gancho de remolque en acero con agujero de 80 mm conforme con la FIA.

€ 39,00



01627GI

## RACERS TAPE

01691 € 19,90

Nastro telato multiuso. Rotoli da 50 m, larghezza 50 mm. Disponibile in 7 colori.

All-purpose heavy duty racer tape. Roll 50 mm wide x 50 metres. 7 different colours. Cinta de tela para todos los usos. Rollos de 50 m, anchura 50 mm. En 7 colores.

01692 € 19,00

Nastro telato alluminizzato. Rotoli da 50 m, largh. 50 mm. Aluminised tape. Roll 50 mm wide x 50 m. Cinta de tela con aluminio. Rollos de 50 m, anchura 50 mm.

0169550 € 19,00

Adesivo trasparente antigraffio. Rotolo da 50 m, largh. 50 mm. Transparent, scratchproof adhesive tape. Roll 50 mm wide x 50 m. Cinta adhesiva trasparente antiarañazo. 50 m, anchura 50 mm.



01691..

0169550

01692

Fissaggio universale ruota di scorta, con nastro ad alta resistenza, completo di cricchetto di serraggio, 3 golfari e 3 piastrine di fissaggio.

Universal spare wheel fastening with high-strength tape, complete with locking ratchet, 3 eyebolts and 3 fixing plates.

Fijación universal de la rueda de repuesto, completo de carraca de apriete, 3 cáncamos y 3 placas de fijación.

€ 32,00



03773

Gancio traino a nastro. Foro perno da 13 mm, carico MAX 3000 kg. Ribbon towing eye. Hole diameter 13 mm, MAX load 3000 kg. Gancho de remolque. Agujero para eje de 13 mm, carga MAX 3000 kg.

€ 17,00



01612RS

Fissaggio chiave a croce con molle di tenuta e gomma antivibrante. Cross spanner fastening with retainer springs and anti-vibration rubber. Fijación de llave en cruz con resortes de retención y goma anti-vibración.

€ 30,00



03776

RACING

# MECHANICS



ISI<sup>®</sup>

# MS-D TOP/BOTTOM

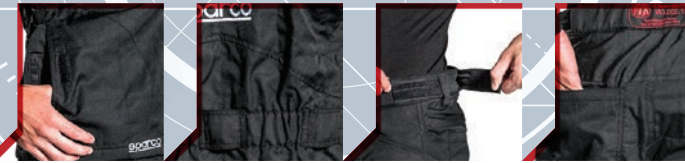

MANUFACTURER: SPARCO  
MODEL: RMO-001  
HOM. NO: MO.004.17  
FIA STANDARD: 8867/2016

Homologation: FIA 8867-2017

Peso • Weight • Peso: 360/390 g/m<sup>2</sup>

Taglia • Size • Tamaño: S-XXXL

TOP € 295,00

BOTTOM € 245,00

**COMPOSIZIONE:** Meta-Aramidica, sandwich due strati.

**CARATTERISTICHE:** Il primo completo, giacca e pantalone progettato per la massima protezione per i meccanici e gli addetti al rifornimento e alla manipolazione di liquidi infiammabili / carburanti al di fuori del "race time", il tutto in conformità al regolamento specifico FIA 8867/2016. Dotate di tutte le caratteristiche tipiche delle tute racing (giro manica completo, inserto elasticizzato schiena, maglieria al-leggerita), sono la perfetta trasposizione dei nostri modelli classici, adattati al nuovo regolamento.

**PERSONALIZZAZIONE:** stampa transfer ignifugi - ricami.

**COMPOSITION:** Meta-Aramid, two-layer sandwich.

**CHARACTERISTICS:** The first suit, jacket and trousers, designed with characteristics that are indispensable in terms of materials and modelling, ensuring maximum protection for mechanics and refuelling personnel and for handling inflammable liquids/fuels out of "race time", all in compliance with the specific FIA 8867/2016 regulation. Provided with all the typical characteristics of racing suits (armholes, elasticised back pad, light fabric mesh) these are the perfect transposition of our classic models, suitable for the new regulations.

**PERSONALISATION:** fireproof transfer printing - embroidery.

**COMPOSICIÓN:** Meta-Aramida, sándwich de dos capas.

**CARACTERÍSTICAS:** El primer conjunto, chaqueta y pantalón, diseñado con características indispensables en cuanto a materiales y confección, con vistas a garantizar la máxima protección para los mecánicos y los encargados del repostaje y del manejo de líquidos inflamables/ combustibles fuera del "race time", todo conforme al reglamento específico FIA 8867/2016. Con todas las características típicas de los monos racing (sisa completa, elemento elastizado en la espalda, tricotos aligerados), son la aplicación perfecta de nuestros modelos clásicos, adaptados al nuevo reglamento.

**PERSONALIZACIÓN:** estampado transfer ignífugo - bordados.



002013JNR..

002013PNR..

# MS-7



Peso • Weight • Peso: 250/300 g/m<sup>2</sup>

Taglia • Size • Tamaño: S-XXL

€ 145,00

**COMPOSIZIONE:** Poliestere/Nylon/Cotone.  
**CARATTERISTICHE:** Tuta meccanica alto di gamma, realizzata dosando una struttura principale in tessuto misto poliestere/cotone, con inserti in parte imbottiti in nylon e in Cordura ad alta tenacità ed anti-abrasione. Caviglie con chiusura regolabile con zip, inserti elasticizzati traforati su giro manica che permettono maggior mobilità e traspirazione. Inserti in Cordura su avambraccio e gambe, in particolare sotto ginocchio con imbottiture che migliorano il confort in fase di appoggio; Inserti elasticizzati sottomanica e generoso inserto elasticizzato su schiena, entrambi completamente traforati per una maggiore mobilità e traspirabilità. Taschini in petto a filetto con chiusura a mezzo cerniere, tasconi con soffietto su gambe con patte di chiusura e tasca porta smartphone, tasche tipo jeans; tasche porta penne applicate su maniche. Ganci per applicazione radio su cintura posteriore; fori passacavi su schiena altezza cintura. Collo e cintura preformati.  
**PERSONALIZZAZIONE:** stampa transfer - ricami.

**COMPOSITION:** Polyester/Nylon/Cotton.  
**CHARACTERISTICS:** High-range mechanic's suit, made by batching a main structure in mixed polyester/cotton fabric, with panels partly nylon-padded and in high-resistance and anti-abrasion Cordura. Ankles with adjustable closure with zip, perforated elasticised panels on the armhole allowing greater mobility and breathability. Cordura panels on the forearm and legs, precisely, below the knee with padding to improve comfort when seated; Elasticised underarm panels and generous elasticised panel on the back, both completely perforated for greater mobility and breathability. Light welt pouches with zip fastener, large pockets with bellows on the legs with closing flaps and smartphone pocket, jeans-type pockets; pen-holder pockets applied on the sleeves. Hooks for application of a radio on the rear belt; cable-holes on the back at belt height. Preformed neck and belt.

**PERSONALISATION:** transfer printing - embroidery.

**COMPOSICIÓN:** Poliéster/Nailon/Algodón.  
**CARACTERÍSTICAS:** Mono de gama alta para mecánico, realizado combinando una estructura principal de tejido mixto poliéster/algodón, con elementos en parte acolchados de nailon y de Cordura de alta resistencia y antiabrasión. Tobilleras con cierre regulable con cremallera, elementos elasticizados calados en la sisa que ofrecen más movilidad y transpirabilidad. Elementos de Cordura en antebrazo y piernas, en particular debajo de la rodilla con acolchados que mejoran la comodidad al apoyarse; elementos elasticizados en axila y elemento elasticizado grande en la espalda, ambos completamente calados para una mejor movilidad y transpirabilidad. Bolsillos ojal con cierre de cremallera, bolsillos grandes con fuelle en las piernas con tapas de cierre y bolsillo portatéfono, bolsillos tipo tejanos; bolsillos portabolígrafo en las mangas. Ganchos para colgar la radio en cintura trasera; orificios para hacer pasar cables en la espalda a la altura de la cintura. Cuello y cintura preformados con el rasgo característico identificador de Sparco.  
**PERSONALIZACIÓN:** estampado transfer - bordados.



002016NR..

002016BM..

# MS-3



Peso • Weight • Peso: 230/250 g/m<sup>2</sup>

Taglia • Size • Tamaño: S-XXL

€ 69,00

**CARATTERISTICHE:** tessuto misto poliestere/cotone leggero e confortevole, il giusto compromesso qualità-prezzo. La tuta è stata progettata dual-use con l'intento sia destinabile al tipico mercato del workwear, che ad un mercato specifico per il kart indoor /noleggino. La vestibilità e l'identificazione taglia sono state quindi ottimizzate e pensate a questo doppio utilizzo. Chiusura regolabile caviglie con velcro, tasche applicate su gambe e maniche. Tasca porta penna con indicazione della taglia. Polsini regolabili con velcro. Tasca su petto con zip.

**PERSONALIZZAZIONE:** stampa transfer - ricami.

**CHARACTERISTICS:** Low-range mechanic's suit made of light and comfortable polyester/cotton mixed fabric, the right economy compromise. The suit has been designed for dual-use with the typical workwear market in mind as well as the specific market, for indoor Kart or rental. Comfort and size identification have therefore been optimised and designed for this double use. Adjustable ankle closure with Velcro, pockets on the legs and sleeves. Pen-holder pocket with indication of size. Adjustable wrist cuffs with Velcro. Breast pocket with zip.

**PERSONALISATION:** transfer printing - embroidery.

**CARACTERÍSTICAS:** tejido mixto poliéster/algodón, ligero y cómodo, justa combinación calidad-precio. El mono ha sido diseñado para doble uso con vistas a ser utilizado tanto en ámbito laboral como en el sector del kart indoor/alquiler. Por lo tanto, se han optimizado y pensado para este doble uso la vestibilidad y la identificación de talla. Cierre regulable con velcro de las tobilleras, bolsillos aplicados en piernas y mangas. Bolsillo portabolígrafo con indicación de la talla. Puños regulables con velcro. Bolsillo delantero con cremallera.

**PERSONALIZACIÓN:** estampado transfer - bordados.



002015RS..

002015AZ..

002015GR..

002015NR..

**SALOPETTE  
DUNGAREES - MONO DE TRABAJO**

Taglia • Size • Tamaño: S-XXL

Tuta con tasche sul davanti e sui lati.  
Overall with pockets on front and sides.  
Mono con bolsillos en la parte delantera y a los lados.

€ 55,00



0020011NR.. 0020011AZ..

**GREMBIULE DA LAVORO  
WORK APRON - DELANTAL DE TRABAJO**

Single Size

€ 25,00



00215N

**MANTELLA  
RAIN CLOAK • CHUBASQUERO 3/4**

Taglia • Size • Tamaño: S/M - L/XL - XXL

€ 45,00



002398..

**NEW****MECA RMG-7**

Homologation: FIA 8856-2000

Taglia • Size • Tamaño: 9-13

**CARATTERISTICHE:** guanto omologato FIA progettato in collaborazione con M-Sport per utilizzo del team Bentley M-Sport. Cuciture interne, pre curvato, cucitura su pollice e indice spostata per evitare vescicole ed abrasioni, rinforzato con spalmatura in silicone FR. Inserti su dorso e polso in silicone FR shock-absorber, rinforzi esterni in silicone spalmato FR su dorso, polso e palmi e in transfer silicnici su dita, per proteggere dal calore ed dall'usura.

**FEATURES:** FIA - homologated glove developed in conjunction with M-Sport for use by Bentley Team M-Sport. Internal seams, pre-curved, deviated seam on thumb and index finger to avoid blisters and rubbing, reinforced with FR silicone coating. Inserts on back and wrist in shock-absorbing FR silicone, external reinforcements in FR silicone coating on the back, wrist and palms and in silicone transfers on the fingers to protect from heat and wear.

**CARACTERÍSTICAS:** guante homologado FIA, diseñado junto con M-Sport para el equipo Bentley M-Sport. Costuras internas, curvado de antemano, costura en pulgar e índice desplazada para evitar ampollas y abrasiones, reforzado con embadurnamiento de silicona FR. Insertos de silicona FR amortiguadores en dorso y muñeca, refuerzos externos de silicona FR distribuida en dorso, muñeca y palma y con transfer silicónicos en los dedos, para proteger frente a calor y desgaste.

€ 120,00



001313..NR

**TIDE MG-9**

Homologation: FIA 8856-2000

Taglia • Size • Tamaño: 8-12

Guanti con palmo preformato ergonomico ad alto grip, shock absorber e rinforzo imbottito sul dorso.  
COMPOSIZIONE: Maglina 100% meta-aramidica. Palmo con rinforzi in HTX 3D "Vulcano" (brevetto Sparco). Dorso con rinforzi in maglia aramidica con spalmatura in silicone.

Gloves with preformed ergonomic high-grip palm, shock absorber and reinforced padded back.  
COMPOSITION: 100% meta-aramid jersey. Palm with 3D "Volcano" HTX reinforcements (Sparco patent). Back with knitted aramid reinforcements with silicone coating.

Guantes con palma preformada ergonómica de gran agarre, absorción de impactos y refuerzo acolchado en el dorso.  
COMPOSICIÓN: Tejido de punto 100% meta-aramida. Palma con refuerzos en HTX 3D "Vulcano" (patente Sparco). Dorso con refuerzos en tejido de punto de aramida con aplicación de silicona.

€ 175,00



001303..NR

## GUANTI DA LAVORO - WORK GLOVES GUANTES DE TRABAJO

Single Size

Guanto meta-aramidico. Guanti di protezione in maglia con polsino elasticizzato e palmo in PVC antiscivolo. Filato 100% meta-aramidico.

Meta-aramid gloves. Protective glove, knitted fabric with knit cuff and PVC non-slip palm. 100% meta-aramid.

Guantes en meta-aramida. Guantes de protección en tejido de malla y muñeca en material elástico e palma en PVC antideslizante. 100% meta-aramidico.

€ 18,00



00210LNX

Single Size

Guanti tessuti a maglia con polsino elasticizzato.

100% para-aramide all'esterno, fodera in cotone all'interno.

Knitted fabric glove with elastic wristband.

100% para-aramid on the outside, cotton lining inside.

Guantes tejidos de punto con muñeca elástica.

100% para-aramida en el exterior, forro de algodón en el interior.

€ 70,00



00205

Single Size

Palmo gommato antiscivolo. Cotone.

Rubber grip on palms. Cotton.

Goma antideslizante en la palma. Algodón.

€ 10,00



00207

00207NR

## MECA III

Taglia • Size • Tamaño: S-XL

Dorso in tessuto elasticizzato e stampato resistente all'abrasione. Il palmo è in pelle sintetica resistente all'abrasione mentre un rinforzo è stato inserito tra il pollice e l'indice. Introduzione di soffietti tra le dita per ottenere una maggiore traspirazione. Cinturino di chiusura con velcro per la regolazione del fitting.

The backs of Meca-3 gloves are made from elasticised, printed, scuff resistant fabric. The palms are in synthetic, scuff resistant hide and there are reinforcements positioned between the thumb and index finger. Pads between the fingers provide better breathing. Velcro belt for tighter fitting.

Dorso de tejido elastizado e estampado resistente a la abrasión. La palma es de piel sintética resistente a la abrasión mientras que se ha puesto un refuerzo entre el pulgar e índice. Fuelles entre los dedos para obtener una mayor transpirabilidad. Cierre con velcro para ajustar la acomodación.

€ 25,00



002093RS

002093AZ

002093NR

## MECA OVERGLOVES

Taglia • Size • Tamaño: S/M/L

€ 45,00



00259NR..

NEW

## MB CREW

NEW



MANUFACTURER: SPARCO  
MODEL: MB CREW  
HOM. NO: TBD  
FIA STANDARD: 8856-2018

Homologation: FIA 8856-2000

Taglia • Size • Tamaño: 38-48

€ 155,00



**CARATTERISTICHE:** nuovissima scarpa realizzata in due tipologie di pelli, una molto morbida e una rinforzata, per avere la miglior calzatura unita alla massima resistenza all'abrasione. Caviglia imbottita, linguetta e zone apposite traforate per la massima traspirabilità, doppio sistema di allacciatura con lacci e strap ultrapiatti, caratteristico taschino Sparco porta lacci, inserto posteriore elasticizzato, fodera ultra leggera e traspirante, soletta ergonomica e shock-absorber, suola in EVA e TPU con design studiato per agevolare i movimenti di meccanici e co-driver.

**FEATURES:** brand new shoe created in two types of leather, one very soft and one reinforced, to provide the best fit together with the maximum resistance to abrasion. Padded ankle, tongue and specific perforated areas for maximum breathability, double lacing system with ultra-flat laces and straps, distinctive Sparco lace holder pocket, elasticised rear insert, ultra-light-weight and breathable lining, ergonomic and shock-absorbing insole, EVA and TPU sole with pattern designed to facilitate the movements of mechanics and co-drivers.

**CARACTERÍSTICAS:** nuevísimo calzado realizado con dos tipos de piel, una muy blanda y una reforzada, para tener la mejor comodidad junto con la máxima resistencia a la abrasión. Tobillo acolchado, lengüeta y zonas expresamente caladas para ofrecer la máxima transpirabilidad, doble sistema de atadura con cordones y tira ultrapianos, bolsillo característico Sparco para cordones, elemento trasero elástico, forro ultraligero y transpirable, plantilla ergonómica y amortiguadora, suela de EVA y TPU con un diseño estudiado para facilitar los movimientos de los mecánicos y de los copilotos.



001265..NR

# MX-RACE

Taglia • Size • Tamaño: 39-48

€ 90,00



Tomaia in rete traspirante con 2 diverse trame. Rinforzo posteriore, laterali e punta in pelle texturizzata. Sistema di allacciatura interno con nastrino passalacci. Soletta interna anatomica preformata. Suola VIBRAM in EVA antistatica, resistente agli oli e agli idrocarburi. CARATTERISTICHE: Massima leggerezza e traspirabilità. Suola VIBRAM ad alto grip con funzione di "shock absorber" e adattamento al terreno per il massimo confort ed il minimo affaticamento. Lacci in 2 differenti colori inclusi nella confezione.

Two types of mesh: high breathability and texture quadrilateral mesh with honeycomb structure. Reinforcements and heel leather textured. Internal lacing system with ribbon loops. Anatomic pre-shaped inner sole. Antistatic VIBRAM sole in EVA, oil and hydrocarbons resistant. FEATURES: Lightweight and breathable. High grip and shock absorber VIBRAM sole for maximum comfort and low stress. Laces in 2 different colours are provided with the package.

Forro delantero en tejido transpirable con 2 distintas tramas. Refuero posterior y laterales en piel texturizada. Sistema de lazada interno con cinta de cierre. Suela interna anatomica preformada. Suela VIBRAM en EVA antistatica, resistente al aceite y a los hidrocarburos. CARACTERISTICAS: Maxima ligereza y respirabilidad. Suela VIBRAM con alta adherencia, "amortiguación" y adaptación al terreno para obtener el maximo confort y la minima fatiga. Cordones en 2 diferentes colores incluidos en el envase.

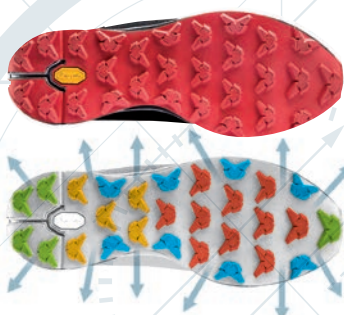

- GRIP
- TRACTION
- BRAKING
- CUSHIONING
- STABILITY
- SELF-CLEANING



001216..NR



## BORSA PORTAUTENSILI • TOOL BAG MOCHILA PORTA HERRAMIENTAS

Zainetto dotato di custodia interna porta attrezzi. Comode tasche esterne. Backpack with internal tool holder. Practical outside pockets. Práctica, provista de funda interior porta herramientas. Bolsillos exteriores.

€ 59,00



01644NGR

## TOOLS BELT

Cintura porta radio regolabile. Radio belts, adjustable. Cinturón ajustable porta radio.

€ 19,00



M-L  
min 90 - max 120 cm

L-XL  
min 120 - max 150 cm

016451ML

016451LXL



KARTING

# SUITS

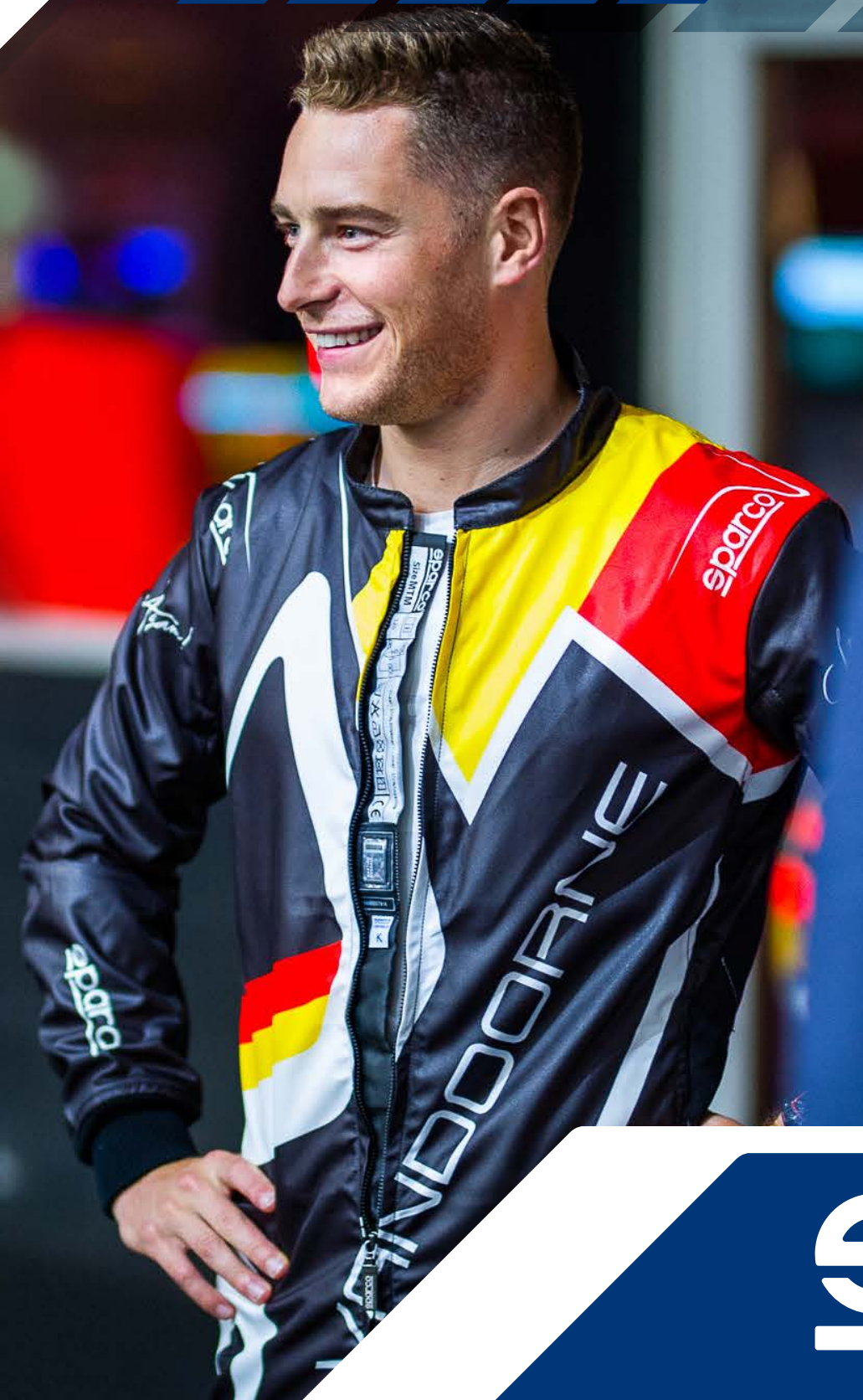

SI<sup>®</sup>

# PRIME KS-10

PREZZI IVA ESCLUSA  
VAT NOT INCLUDED • PRECIOS SIN IVA



MANUFACTURER: SPARCO  
MODEL: K38 PRIME KS-10  
HOM. NO: CIK-FIA 2013/023  
FIA STANDARD: N 2013-1

Homologation: CIK-FIA N2013.1 CE

Peso • Weight • Peso: 440/460 g/m<sup>2</sup>

Taglia • Size • Tamaño: 44-62 € 379,00

Kid Size: 120-150 € 349,00

La tuta kart Prime KS-10 è stata studiata e progettata con l'obiettivo di poter essere totalmente personalizzabile a mezzo stampe e nel contempo garantire al pilota leggerezza, comfort e traspirabilità.

**COMPOSIZIONE:** Poliestere/Poliamide. Sandwich 2 strati con peso complessivo intorno ai 440/460 g/m<sup>2</sup>.

**CARATTERISTICHE:** La tuta Prime KS-10 è una tuta due strati, con inserto mezzo giro manica e pannello schiena elasticizzati. Inserti traforati su schiena, sottomanica, interno gamba ed esterno polpaccio per rendere la tuta la più traspirante possibile, diminuendo così la condensazione del sudore, e aumentando il comfort. Cerniera baciata e collo ribassato. Tasche inserite e cintura classica. La tuta è stata ottimizzata in tutte le sue parti per essere personalizzata a mezzo stampe. Protezioni schiena in Cordura® incrementano la protezione all'usura nei punti di maggiore contatto con il seggiolino kart.

The Prime KS-10 kart suit was specifically designed to be fully personalised using prints while at the same time offering the driver light weight, comfort and breathability.

**COMPOSITION:** Polyester/Polyamide. Two-layer sandwich with overall weight of about 440/460 g/m<sup>2</sup>.

**CHARACTERISTICS:** The Prime KS-10 suit has two layers with elasticised panels at the armpits and back. Perforated panels at the back, armpits, inner leg and outer thigh allow the suit to breathe and thus minimise the condensation of sweat and improve comfort. Ribbed neck and concealed zip. Pockets and classic belt. The suit can be fully personalised with prints. Cordura® back protection which increases resistance to wear and tear at the points in most contact with the kart seat.

El mono de kart Prime KS-10 ha sido estudiado y diseñado en vistas de ser completamente personalizable mediante estampados y al mismo tiempo garantizar al piloto, liviandad, comfort y transpirabilidad.

**COMPOSICIÓN:** Poliéster/Poliamida. Sandwich de 2 capas con peso total alrededor de 440/460 g/m<sup>2</sup>.

**CARACTERÍSTICAS:** El mono Prime KS-10 es un mono de dos capas, con inserto media sisa y panel de espalda elasticizado. Insertos calados en la espalda, las axilas, interior pierna y exterior pantorrilla para que el mono sea lo más transpirable posible, disminuyendo de esta forma la condensación del sudor y aumentando el comfort. Cremallera doble y cuello rebajado. Bolsillos aplicados y cintura clásica. El mono ha sido optimizado en todas sus partes para personalizarlo mediante estampados. Protecciones de espalda de Cordura® incrementan la protección frente al desgaste en los puntos de mayor contacto con el asiento del kart.



002306..NR

# X-LIGHT KS-7



MANUFACTURER: SPARCO  
MODEL: K41 X-LIGHT KS-7  
HOM. NO: CIK-FIA 2013/023  
FIA STANDARD: N 2013-1

Homologation: CIK-FIA N2013.1 CE

Peso • Weight • Peso: 380/400 g/m<sup>2</sup>

Taglia • Size • Tamaño: 44-62 € 335,00

Kid Size: 120-150 € 305,00

Realizzata con un tessuto di nuova generazione in poliestere ad altissima tenacità.  
**COMPOSIZIONE:** Poliestere/Poliammide. Sandwich 2 strati con peso complessivo intorno ai 380/400 g/m<sup>2</sup>.  
**CARATTERISTICHE:** Tuta due strati con giro manica completo. Pannello schiena ed inserti ginocchio elasticizzati di ampie dimensioni al fine di incrementare il comfort. Inserti traforati su sottomanica, interno gamba ed esterno polpaccio per rendere la tuta la più traspirante possibile, diminuendo così la condensazione del sudore, e aumentando il comfort. Cerniera coperta e collo alleggerito con interno traforato. Tasche inserite e cintura classica. Maniche preformate.

The X-Light KS-7 kart suit is made from a new generation polyester fabric with excellent resistance properties.  
**COMPOSITION:** Polyester/Polyamide. Two-layer sandwich with overall weight of about 380/400 g/m<sup>2</sup>.  
**CHARACTERISTICS:** The X-Light KS-7 suit has two layers and complete armholes. Back panel and large elasticised knee inserts to increase comfort. Elasticised perforated panels at the armpits, inner leg and outer thigh allow the suit to breathe and thus minimise the condensation of sweat and improve comfort. Covered zip and lightened neck with perforated inner surface. Pockets and classic belt. Preformed sleeves.

El mono de kart X-Light KS-7 ha sido realizado con un tejido de nueva generación de políester de altísima tenacidad.  
**COMPOSICIÓN:** Poliéster/Poliámid. Sandwich de 2 capas con peso total alrededor de 380/400 g/m<sup>2</sup>.  
**CARACTERÍSTICAS:** El mono X-Light KS-7 es un mono de dos capas con sisa completa. Panel de espalda e insertos de rodilla elasticizados y grandes para incrementar el comfort. Insertos calados elasticizados en las axilas, interior de pierna y exterior de pantorrilla para que el mono sea lo más transpirable posible, disminuyendo de esta forma la condensación del sudor y aumentando el comfort. Cremallera tapada y cuello aligerado con interior calado. Bolsillos aplicados y cintura clásica. Mangas preformadas.



002336..BRSN

002336..GRSCE

002336..NRGRS

# ROBUR KS-5



MANUFACTURER: SPARCO  
MODEL: K40 ROBUR KS-5  
HOM. NO: CIK-FIA 2013/023  
FIA STANDARD: N 2013-1

Homologation: CIK-FIA N2013.1 CE

Peso • Weight • Peso: 480/500 g/m<sup>2</sup>

Taglia • Size • Tamaño: XS-XXL

€ 269,00

**COMPOSIZIONE:** Poliammide Cordura®. Sandwich 2 strati con peso complessivo intorno ai 480/500 g/m<sup>2</sup>.

**CARATTERISTICHE:** La tuta ROBUR KS-5 è una tuta due strati, con giro manica completo e pannello schiena elasticizzato di ampie dimensioni al fine di incrementare il comfort. Inserti in Cordura® traforato su fianchi e fondo schiena ad altissima tenacità. Inserti traforati su sottomanica e interno gamba per rendere la tuta la più traspirante possibile, diminuendo così la condensazione del sudore, e aumentando il comfort. Collo totalmente traspirante grazie all'utilizzo di entrambe i materiali traforati già presenti nella realizzazione della tuta. Cerniera baciata, tasche inserite e cintura classica. Maniche preformate.

**COMPOSITION:** Polyamide Cordura®. Two-layer sandwich with overall weight of about 480/500 g/m<sup>2</sup>.

**CHARACTERISTICS:** The ROBUR KS-5 suit has two layers, and complete armholes with a large elasticised back panel to improve comfort. There are perforated high resistance Cordura® inserts at the sides and bottom. Elasticised perforated panels at the armpits, inner leg and outer thigh allow the suit to breathe and thus minimise the condensation of sweat and improve comfort. The whole neck area can breathe thanks to the use of both the perforated materials used in making the suit. Concealed zip, pockets and classic belt. Preformed sleeves.

**COMPOSICIÓN:** Poliamida Cordura®. Sándwich de 2 capas con peso total alrededor de 480/500 g/m<sup>2</sup>.

**CARACTERÍSTICAS:** El mono ROBUR KS-5 es un mono de dos capas, con sisa completa y panel de espalda elasticizado grande para incrementar el comfort. Insertos de Cordura® calado en los flancos y fondo espalda de altísima tenacidad. Insertos calados en las axilas e interior de pierna para que el mono sea lo más transpirable posible, disminuyendo de esta forma la condensación del sudor y aumentando el comfort. Cuello completamente transpirable utilizando ambos materiales calados ya presentes en la realización del mono. Cremallera doble, bolsillos aplicados y cintura clásica. Mangas preformadas.



002335..AAFB

002335..BGSR

002335..GSGB

002335..NGSB

# GROOVE KS-3

**NEW**



MANUFACTURER: SPARCO  
MODEL: K39 GROOVE KS-3  
HOM. NO: CIK-FIA 2013/023  
FIA STANDARD: N 2013-1

Homologation: CIK-FIA N2013.1 CE

Peso • Weight • Peso: 500/540 g/m<sup>2</sup>

Taglia • Size • Tamaño: XS-XXL € 167,00

Kid Size: 120-150 € 157,00

La tuta kart GROOVE KS-3 è realizzata in tessuto Cordura®.  
**COMPOSIZIONE:** Poliammide Cordura®. Sandwich 2 strati con peso complessivo intorno ai 500/540 g/m<sup>2</sup>.  
**CARATTERISTICHE:** La tuta GROOVE KS-3 è una tuta due strati, con giro manica completo e pannello schiena elasticizzato. Inserti traforati su sottomanica, interno gamba per rendere la tuta la più traspirante possibile, diminuendo così la condensazione del sudore, e aumentando il comfort. Collo ribassato, Cerniera baciata, tasche inserite e cintura classica. Maniche preformate.

The GROOVE KS-3 kart suit is made from Cordura® fabric.  
**COMPOSITION:** Polyamide Cordura®. Two-layer sandwich with overall weight of about 500/540 g/m<sup>2</sup>.  
**CHARACTERISTICS:** The GROOVE KS-3 suit has two layers, complete armholes and an elasticised back panel. Elasticised perforated panels at the armpits, inner leg allow the suit to breathe and thus minimise the condensation of sweat and improve comfort. Ribbed neck, concealed zip, pockets and classic belt. Preformed sleeves.

El mono de kart GROOVE KS-3 es en tejido Cordura®.  
**COMPOSICIÓN:** Poliamida Cordura®. Sandwich de 2 capas con peso total alrededor de 500/540 g/m<sup>2</sup>.  
**CARACTERÍSTICAS:** El mono GROOVE KS-3 es un mono de dos capas, con sisa completa y panel de espalda elasticizado. Insertos calados elasticizados en las axilas, interior de pierna para que el mono sea lo más transpirable posible, disminuyendo de esta forma la condensación del sudor y aumentando el comfort. Cuello bajo, cremallera doble, bolsillos aplicados y cintura clásica. Mangas preformadas.



002334..RSBI    002334..AZBI    002334..SINR    002334..NRAF    002334..NRSI    002334..NRCE

# TRACK KS-1



Taglia • Size • Tamaño: XS-XXL

€ 122,00

Track KS-1 è stata pensata per gare dove non è richiesta l'omologazione CIK-FIA.

**COMPOSIZIONE:** Poliammide/Poliester. Sandwich 2 strati: 250 g/m<sup>2</sup>.

**CARATTERISTICHE:** tuta due strati con tessuto esterno leggero e resistente, fodera interna traforata e traspirante. Completa di mezzo giro manica ed aeratori traforati ed elasticizzati su interno gamba, schiena e sottomanica. Collo, alleggerito e ribassato, con una fodera traforata per una migliore traspirabilità. Tasche inserite e cerniera baciata.

The Track KS-1 kart suit was designed for use in races where CIK-FIA approval is not required.

**COMPOSITON:** Polyamide/Polyester. Two-layer sandwich: 250 g/m<sup>2</sup>.

**CHARACTERISTICS:** The Spring KS-1 suit has two layers with a light, resistant outer fabric and a breathable, perforated inner lining. The suit also features floating sleeves and perforated, elasticised air inlets in the inner leg, back and underarm areas. The lighter, lower neck is made with a perforated lining to improve the suit's breathing properties. Patch pockets and concealed zip.

El mono de kart Track KS-1 ha sido diseñado para utilizarlo en carreras que no exigen la homologación CIK-FIA.

**COMPOSIZIONE:** Poliamida/Poliéster. Sándwich de 2 capas: 250 g/m<sup>2</sup>.

**CARACTERÍSTICAS:** El mono Spring KS-1 es un mono de dos capas con tejido externo ligero y resistente y forro interno completamente calado y transpirable. El mono incluye media sisa y elementos de aireación calados y elasticizados en interior pierna, espalda y axilas. El cuello, aligerado y rebajado, está realizado con un forro calado para mejorar la transpirabilidad. Bolsillos aplicados y cremallera doble.



002337..SI

002337..NR



# T-1

Taglia • Size • Tamaño: S-XXL

Kid Size: 120-150

TUTA ANTIPIOGGIA  
KARTING RAINWEAR • MONO ANTILLUVIA

Sovratuta in materiale trasparente che non ingiallisce nel tempo. Made of transparent material that doesn't become yellow.

Material transparente que no se amarillea con el pasar del tiempo para este mono. para ajustar la acomodación.

€ 49,00



00239T..

MANTELLA  
RAIN CLOAK • CHUBASQUERO 3/4

Taglia • Size • Tamaño: S/M - L/XL - XXL

€ 45,00



002398..

KARTING

# RIB PROTECTORS



ISI<sup>®</sup>

# IL CARBONIO



**NEW**



**S.I. TECH**

## SPARCO IMPACT TECHNOLOGY

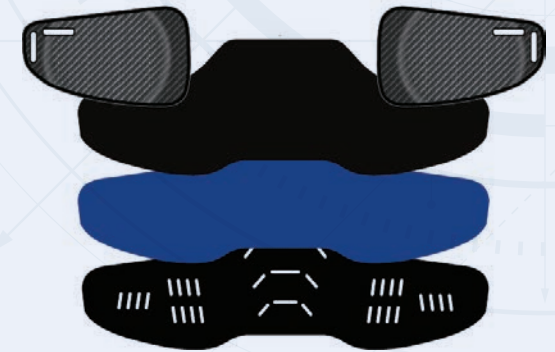

**Sparco Impact Technology:** la nuova tecnologia made in SPARCO® sviluppata combinando un materiale EPDM dello spessore di 4 mm con un PU espanso di 6 mm che garantiscono un'incredibile performance in termini di anti-vibrazione e shock absorber. Tutte le prestazioni di assorbimento di energia sono state verificate tramite prova di attenuazione d'impatto prevista dalla normativa EN 1621-2 con massa di 2500 g (10 Joule) e altezza di caduta 50 cm.

**Sparco Impact Technology:** the new technology made in SPARCO® developed by combining a 4 mm EPDM material with a 6 mm PU foam that provides an incredible performance in terms of anti-vibration and shock absorber. All the energy absorption performances have been verified with an impact attenuation test foreseen by the EN 1621-2 standard with a mass of 2500 g (10 Joule) and a fall height of 50 cm.

**Sparco Impact Technology:** la nueva tecnología SPARCO® desarrollada al combinar un material EPDM de 4 mm con una espuma de PU de 6 mm que proporciona un rendimiento increíble en términos de antivibración y amortiguación. Todo el rendimiento de absorción de energía se verificó con una prueba de atenuación de impacto según EN 1621-2 con una masa de 2500 g (10 Joules) y una altura de caída de 50 cm.

Entirely designed and developed in Italy, thanks to the multi-year experience of SPARCO® in the field of composite materials, the new corset protection CARBON for kart pilots offers maximum protection combined with an incredible lightness that only the carbon fiber shells can give. The two inner layers of foam material with shock absorbing function (EPDM and PU have been specifically sized for the application) derive from the experience gained on Racing seats and on different applications for Supercars. CARBON is equipped with ultra-light tape of the latest generation, the same used on FIA approved belts to offer the highest level of resistance, safety and comfort for the pilot who wants to wear the top of the corset protection line. CARBON, in addition to having a wide range of sizes, is further adjustable in height, thanks to a new ultra-strong velcro.

Totalmente diseñado y desarrollado en Italia, gracias a la experiencia multianual de SPARCO® en el campo de los materiales compuestos, el nuevo chaleco de protección CARBON para pilotos de kart ofrece la máxima protección combinada con una increíble ligereza que solo las cáscaras de fibra de carbono pueden proporcionar. Las dos capas internas de material de espuma con función de amortiguación (EPDM y PU se han dimensionado específicamente para la aplicación) se derivan de la experiencia adquirida en los asientos Racing y en diferentes aplicaciones para los Supercars. El chaleco de protección CARBON está equipado con cinta ultraligera de última generación, la misma que se usa en las correas homologadas por la FIA para ofrecer el más alto nivel de resistencia, seguridad y comodidad para el piloto que quiera usar la parte superior de la línea de chalecos protectores. CARBON, además de tener una amplia gama de tamaños, es más ajustable en altura, gracias a un nuevo velcro ultra fuerte.

Taglia • Size • Tamaño: XS-XXL € 235,00

Interamente progettato e sviluppato in Italia grazie all'esperienza pluriennale di SPARCO® in ambito di materiali compositi, il nuovo corpetto per i piloti kart IL CARBONIO offre la massima protezione unita ad un'incredibile leggerezza che solamente le scocche in fibra di carbonio possono dare. I due strati interni in materiale espanso con funzione shock absorbing (EPDM e PU sono stati dimensionati specificatamente per l'applicazione) derivano dall'esperienza maturata su sedili Racing e su diverse applicazioni per le Supercar. IL CARBONIO è dotato di nastro ultraleggero di ultima generazione, lo stesso utilizzato sulle cinture omologate FIA per offrire il più alto livello di resistenza, sicurezza e comfort per il pilota che vuole indossare il top di gamma nel panorama dei corpetti protettivi. IL CARBONIO oltre ad avere un'ampia gamma taglie, è ulteriormente regolabile in altezza, grazie ad un nuovo velcro ultrasensibile.

002404K..



# RIB PRO-K7

**NEW**

**S.I. TECH**

## SPARCO IMPACT TECHNOLOGY

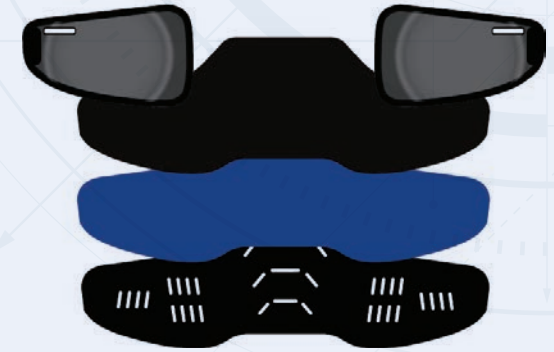

**Sparco Impact Technology:** la nuova tecnologia made in SPARCO® sviluppata combinando un materiale EPDM dello spessore di 4 mm con un PU espanso di 6 mm che garantiscono un'incredibile performance in termini di anti-vibrazione e shock absorber. Tutte le prestazioni di assorbimento di energia sono state verificate tramite prova di attenuazione d'impatto prevista dalla normativa EN 1621-2 con massa di 2500 g (10 Joule) e altezza di caduta 50 cm.

**Sparco Impact Technology:** the new technology made in SPARCO® developed by combining a 4 mm EPDM material with a 6 mm PU foam that provides an incredible performance in terms of anti-vibration and shock absorber. All the energy absorption performances have been verified with an impact attenuation test foreseen by the EN 1621-2 standard with a mass of 2500 g (10 Joule) and a fall height of 50 cm.

**Sparco Impact Technology:** la nueva tecnología SPARCO® desarrollada al combinar un material EPDM de 4 mm con una espuma de PU de 6 mm que proporciona un rendimiento increíble en términos de antivibración y amortiguación. Todo el rendimiento de absorción de energía se verificó con una prueba de atenuación de impacto según EN 1621-2 con una masa de 2500 g (10 Joules) y una altura de caída de 50 cm.

RIB PRO K-7 is the kart corset for the pilot that requires maximum protection with the best quality-price ratio. The shells of the corset have been developed in fiberglass laminated manually and painted with the same technology used for racing helmets worn by the latest generation pilots. The edge of the shells is covered in rubber to eliminate any possible abrasion with the suit, giving to the product an aggressive look. RIB PRO K-7 in addition to the fiberglass element, is composed of two different layers (EPDM and PU) to cushion even the smallest impact when driving. The corset has been studied and designed in every last detail: special internal grooves have been introduced that allow greater breathability and ventilation for the pilot, while the tape adjustment system, the same developed for CARBON, allows each pilot to customize the wearability at his desire.

RIB PRO K-7 es el chaleco de protección de kart para el piloto que requiere la máxima protección con la mejor relación calidad-precio. Las conchas del chaleco de protección se han desarrollado en fibra de vidrio laminada manualmente y pintadas con la misma tecnología utilizada para los cascos de carreras usados por los pilotos de última generación. El borde de las conchas está cubierto de goma para eliminar cualquier posible abrasión con el traje, dando al producto un aspecto agresivo. RIB PRO K-7 además del elemento de fibra de vidrio, se compone de dos capas diferentes (EPDM y PU) para amortiguar el menor impacto al conducir. El chaleco de protección ha sido estudiado y diseñado hasta el último detalle: se han introducido ranuras internas especiales que permiten una mayor transpirabilidad y ventilación para el piloto, mientras que el sistema de ajuste de cinta, el mismo desarrollado para CARBON, permite que cada piloto personalice su capacidad de uso según su deseo.

Taglia • Size • Tamaño: XS-XXL € 155,00

RIB PRO K-7 è il corpetto kart per il pilota che richiede la massima protezione con il miglior rapporto qualità-prezzo. Le scocche del corpetto sono state sviluppate in vetroresina laminata a mano e successivamente verniciate con la stessa tecnologia utilizzata per i caschi racing indossati dai piloti di ultima generazione. Il bordo delle scocche è rivestito in gomma per eliminare ogni possibile abrasione con la tuta indossata conferendo al prodotto un look aggressivo. RIB PRO K-7 oltre all'elemento vetroresina, viene composto da due strati diversi (EPDM e PU) per attutire anche il più piccolo urto durante la guida. Il corpetto è stato studiato e progettato nei minimi particolari: sono state introdotte speciali scanalature interne che consentono una maggiore traspirabilità ed aerazione per il pilota, mentre il sistema di regolazione del nastro è lo stesso sviluppato per IL CARBONIO e consente ad ogni pilota di personalizzare la vestibilità a proprio piacimento.

002403K..

# SJ PRO-K3

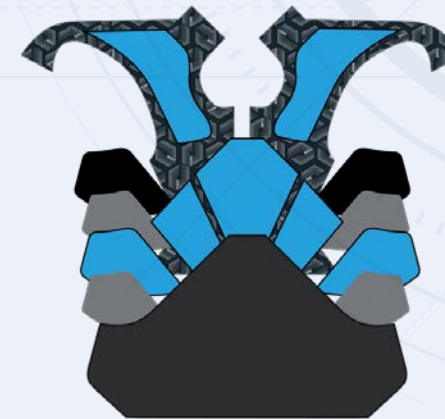
**NEW**

Taglia • Size • Tamaño: XS-XL € 95,00  
Kid Size: 120-140 € 95,00

Questo giubbotto protettivo è stato pensato per un utilizzo sia outdoor che indoor per il pilota non necessariamente professionista che vuole garantirsi alte prestazioni di assorbimento urti e anti-vibrazione senza rinunciare alla comodità e alla leggerezza. Il tessuto esterno si caratterizza per una grande traspirabilità unita ad un'ottima resistenza all'abrasione e agli strappi. È inoltre traspirante e antibatterico per garantire il massimo comfort anche durante le sessioni di guida più intense. L'imbottitura sulla schiena è preformata e le scanalature sono state sviluppate appositamente per agevolare il pilota durante la guida. SJ PRO K-3 è stato sviluppato sia per il pilota outdoor che per quello indoor, con un ampissimo range di taglie necessario per coprire le esigenze del pilota bimbo come quelle del pilota adulto. La chiusura è frontale e grazie alla comoda zip consente al pilota di indossare il giubbotto velocemente.

This protective jacket has been designed for both outdoor and indoor use, for the non-professional pilot who wants to ensure high shock absorption and anti-vibration performance without sacrificing comfort and lightness. The outer fabric is characterized by a great breathability combined with excellent resistance to abrasion and tearing. It is also breathable and antibacterial to ensure maximum comfort even during the most intense driving sessions. The padding on the back is preformed and the grooves have been specially developed to facilitate the pilot while driving. SJ PRO K-3 has been developed for both outdoor and indoor riders, with a very wide range of sizes necessary to cover the needs of the child pilot as those of the adult pilot. The frontal zip closure allows the pilot to wear the jacket quickly.

Esta chaqueta protectora ha sido diseñada para uso en interiores y exteriores, para el piloto no profesional que desea garantizar una alta absorción de impactos y un rendimiento antivibratorio sin sacrificar la comodidad y la ligereza. El tejido exterior se caracteriza por una gran transpirabilidad combinada con una excelente resistencia a la abrasión y al desgarro. También es transpirable y antibacteriano para garantizar la máxima comodidad incluso durante las sesiones de conducción más intensas. El acolchado en la parte posterior está preformado y las ranuras se han desarrollado especialmente para facilitar al piloto mientras se conduce. SJ PRO K-3 ha sido desarrollado para pilotos tanto de interior como de exterior, con una amplia gama de tamaños necesarios para cubrir las necesidades del piloto infantil como las del piloto adulto. El cierre con cremallera frontal permite al piloto a llevar la chaqueta rápidamente.

002402K..

KARTING

# UNDERWEAR



SI<sup>®</sup>

# SEAMLESS

La nuova maglieria specifica per il kart è realizzata con una struttura doppia in poliestere/polipropilene al fine di garantire il massimo comfort e la massima idrofilicità del prodotto. La maglieria è realizzata attraverso una smacchinatura definita "body-size" dove il capo è prodotto in unica soluzione eliminando le cuciture laterali. Questo tipo di lavorazione permette di creare diverse aree più o meno elasticizzate a seconda delle necessità. La presenza di zone più elasticizzate agevola la vestibilità del capo.

**COMPOSIZIONE:** 50% poliestere - 50% Polipropilene. Tessuto con un peso medio di 150/180 g/m<sup>2</sup>.

The new racewear for kart drivers features a twin polyester/polypropylene structure to offer maximum comfort and water repellent properties. The new racewear is made by means of a processing method known as "body-size" in which the garment is produced as a single piece item with no stitching at the sides. This type of process means different sections can be made more or less elastic to meet differing needs. The existence of more elastic sections makes the garment more comfortable to wear.

**COMPOSITION:** 50% polyester - 50% Polypropylene. Average weight of fabric 150/180 g/m<sup>2</sup>



**Sottocasco monostrato realizzato con pochissime cuciture ultrasottili e piatte.** Struttura differenziata con inserti elastici al fine di garantire un maggiore comfort. Apertura occhi rifinita piatta per un maggiore comfort.

**Single layer balaclava with minimal ultra-thin, flat stitching.** Differentiated structure with elasticised panels for maximum comfort. Flat eye holes for increased comfort.

**Sotocasco de una sola capa realizado con poquísimas costuras ultrafinas y planas.**

Estructura diferenciada con insertos elásticos para garantizar un mayor comfort. Abertura para los ojos acabada plana para un mayor comfort.

Single size

€ 29,90

002286BI...



**Maglia manica lunga con collo basso.**

Struttura della maglia differenziata per ottenere un maggiore comfort ed incrementare la traspirabilità in alcune zone specifiche. La manica raglan conferisce al capo una vestibilità più confortevole poiché le cuciture delle maniche vengono posizionate in zone meno soggette a pressioni e schiacciamenti. Polsini e fondo maglia rifiniti più sottili per un maggiore comfort.

**Long-sleeved vest with low neckline.**

Differentiated mesh structure to provide better comfort and enhance breathability in different specific areas. The raglan sleeve pattern makes the garment more comfortable thanks to the fact that the stitching for the sleeves is positioned in an area that is subjected to less pressure. The wrists and waist have finer stitching for increased comfort.

**Camiseta de manga larga con cuello bajo.**

Estructura del punto diferente para obtener un mayor comfort e incrementar la transpirabilidad en algunas zonas específicas. La manga raglán ofrece a la prenda un calce más cómodo ya que las costuras de las mangas están en zonas meno sujetas a presiones y aplastamientos. Puños y fondo acabados más finos para un mayor comfort.

Size: XS/S - M/L - XL/XXL

€ 60,00

002284MBI...

Los nuevos géneros de punto específicos para el kart se realizan con una estructura doble de poliéster/polipropileno en vistas de garantizar el máximo comfort y para que el producto sea lo más hidrófilo posible. Los géneros de punto se realizan con una elaboración denominada "body-size", que permite fabricar la prenda de una sola vez sin costuras laterales. Este tipo de elaboración permite crear diferentes áreas más o menos elásticas según las necesidades. La presencia de zonas más elásticas facilita el calce de la prenda.

**COMPOSICIÓN:** 50% Poliéster - 50% Polipropileno. Tejido con un peso medio de 150/180 g/m<sup>2</sup>



**T-shirt mezza manica con collo basso.**

Struttura della maglia differenziata per ottenere un maggiore comfort ed incrementare la traspirabilità in alcune zone specifiche. La manica raglan conferisce al capo una vestibilità più confortevole poiché le cuciture delle maniche vengono posizionate in zone meno soggette a pressioni e schiacciamenti. Polsini e fondo maglia rifiniti più sottili per un maggiore comfort.

**Short-sleeved T-shirt with low neckline.**

Differentiated mesh structure to provide better comfort and enhance breathability in different specific areas. The raglan sleeve pattern makes the garment more comfortable thanks to the fact that the stitching for the sleeves is positioned in an area that is subjected to less pressure. The wrists and waist have finer stitching for increased comfort.

**T-shirt de manga corta con cuello bajo.**

Estructura del punto diferente para obtener un mayor comfort e incrementar la transpirabilidad en algunas zonas específicas. La manga raglán ofrece a la prenda un calce más cómodo ya que las costuras de las mangas están en zonas meno sujetas a presiones y aplastamientos. Puños y fondo acabados más finos para un mayor comfort.

Size: XS/S - M/L - XL/XXL

€ 50,00

002285TBI...

La ricarica X-Cool permette il prolungamento del trattamento rinfrescante sulla tuta e sull'underwear (maglia, pantalone e calze). L'applicazione può essere effettuata con un semplice lavaggio in lavatrice.

Simply add to your washing machine before washing overalls or underwear and the original X-Cool treatment is recharged. Treats one racersuit or 1 set of underwear (pant, top and socks).

La recarga de X-Cool permite la extensión del tratamiento rinfrescante en el mono y en la ropa interior (camiseta, pantalón y calcetines). La aplicación puede realizarse con un simple lavado en la lavadora.

€ 29,00



001157RECHARGE

Texture differenti nelle zone del piede con maggiore spessore nelle zone di contatto. Filo Coolmax®.

Variable textures and increased thickness at the contact points. Coolmax® thread.

Texturas diferentes según la zona del pie con mayor espesor en las zonas de contacto. Hilo Coolmax®.

Size: XS - S - L - XXL

€ 10,00



002271BICE..

# BASIC

**COMPOSIZIONE:** Coolmax /Poliestere.

**CARATTERISTICHE:** Cuciture piatte con filo extra sottile. Utilizzo di due diverse tipologie di materiali all'interno del capo: Jersey estremamente sottile 100% Coolmax e stretch; double traforato per una migliore traspirabilità. Solo le parti in Jersey sono trattate X-Cool silver per una sensazione di freschezza in presenza di alte temperature ad effetto antibatterico. Maglie, e T-Shirts, realizzati con vestibilità asciutta, appositamente studiati per la posizione di guida. Sottocasco apertura unica.

**COMPOSITION:** Coolmax /Poliestere.

**CHARACTERISTICS:** Flat seams thanks to the use of the extra thin thread. Two different technologies have been used: thin and stretch Jersey 100%Coolmax; double perforated to increase breathability. Jersey parts are treated with X-cool silver for a fresh feeling also with high temperatures, antibacterial effect. Shirt and T-Shirts, slim fit, designed to be comfortable in a driving position. Balaclava single opening.



Cuciture extra piatte.  
Extra flat seams.  
Costuras extra planas.

Single size

€ 9,90

002231B

002231N



Size: XS - XL

€ 32,00

00224B

00224N



Size: XS - XL

€ 26,00

00226B

00226N

## GINOCCHIERE - KNEE PADS RODILLERAS



€ 15,00

00154KN

## GOMITIERE - ELBOW PADS CODERAS



€ 15,00

00155EN

ARTICOLI BIMBO - KIDS ARTICLES  
ARTÍCULOS INFANTILES



PRIME KS-10  
> PAGE 224



X-LIGHT KS-7  
> PAGE 226



GROOVE KS-3  
> PAGE 230



T-1  
> PAGE 234



ARROW KG-7.1  
> PAGE 261



TRACK KG-3  
> PAGE 264



CRW  
> PAGE 265



GAMMA KB-4  
> PAGE 256



SJ PRO K-3  
> PAGE 240



> PAGE 271

ARTICOLI PER KART NOLEGGIO - ARTICLES FOR RENTING KART  
ARTÍCULOS PARA ALQUILER DE KARTS



CLUB J-1 > PAGE 118



CLUB X-1 > PAGE 111



MECA 3 > PAGE 218



Sottocasco 100% cotone.  
Balaclava 100% cotton. - Forro de 100% algodón.  
€ 32,00 (6 PCS)

00222ZBSIX

PREZZI IVA ESCLUSA  
VAT NOT INCLUDED - PRECIOS SIN IVA

KARTING

PREZZI IVA ESCLUSA  
VAT NOT INCLUDED - PRECIOS SIN IVA

KARTING

KARTING

# SHOES



SI<sup>®</sup>

# SUPERLEGGERA KB-10

Taglia • Size • Tamaño: 36-48

€ 285,00



**SUPERLEGGERA KB-10:**  
IL MEGLIO DELLA TECNICITÀ IN FATTO  
DI INNOVAZIONE E MATERIALI.

**COMPOSIZIONE:** la tomaia dello stivaletto Superleggera KB-10 è realizzata in tessuto stampato traspirante con sovra iniezione in TPU ad alta resistenza all'abrasione. Il TPU è sovra iniettato sul tessuto per evitare cuciture. Rinforzo in vera pelle. Para malleolo in materiale 3D imbottito e resistente all'abrasione. Allacciatura interna. Fussbett interno. Lo stivaletto Superleggera KB-10 è provvisto di inserto elasticizzato posteriore, posizionato sopra al tallone, per migliorare la calzata e il fitting, agevolando il movimento della caviglia durante la guida. Suola sagomata leggera ed asimmetrica con rinforzo laterale esterno integrato a rinforzo della zona di maggiore usura che appoggia al pedale.

**SUPERLEGGERA KB-10 KART BOOTS**  
OFFER A HIGH-TECH SOLUTION FROM  
INNOVATION AND MATERIALS.

**COMPOSITION:** the Superleggera KB-10 uppers are made from a breathable pressed fabric with scuff resistant injected moulded TPU. The TPU is injection moulded on the fabric to avoid the use of stitching. Leather reinforcements. Heel protector in padded scuff resistant 3D material. Internal laces. Insoles. Superleggera KB-10.1 racing boots have an elasticised panel at the rear just above the heel to improve fit and allow the ankle to move freely when driving. Light asymmetrical soles with integrated external reinforcement for the area most affected by wear from using the pedals.

**EL BOTÍN DE KART SUPERLEGGERA**  
KB-10 OFRECE LO MEJOR EN CUANTO  
A INNOVACIÓN Y MATERIALES.

**COMPOSICIÓN:** la pala del botín Superleggera KB-10 es en tejido estampado transpirable con sobreinyección de TPU de alta resistencia a la abrasión. El TPU se inyecta sobre el tejido para evitar costuras. Refuerzo de piel. Protector de maléolo de material 3D acolchado y resistente a la abrasión. Abrochado interno. Fussbett interno. El botín Superleggera KB-10 lleva un inserto elastizado trasero, situado encima del talón, para mejorar el ajuste, facilitando el movimiento del tobillo mientras se conduce. Suela perfilada ligera y asimétrica con refuerzo lateral externo incorporado para reforzar la zona de mayor desgaste que se apoya en el pedal.



001256...NRRS



# OMEGA KB-6

Taglia • Size • Tamaño: 36-48

€ 99,00



Lo stivaletto kart Omega KB-6 offre un ottimo contenimento del peso abbinato ad una buona traspirabilità.

**COMPOSIZIONE:** la tomaia dello stivaletto Omega KB-6 è realizzata in tessuto traspirante stampato con inserti in vera pelle. Fodera interna traspirante. Soletta interna anatomica. Rinforzo nella zona del mallole e inserto elasticizzato posteriore, posizionato sopra al tallone, per migliorare la calzata e il fitting, agevolando il movimento della caviglia durante la guida. Nuova suola in gomma asimmetrica con rinforzo laterale esterno. Chiusura a cinghietto con anello passante.

Omega KB-6 kart boots offer light weight and excellent breathing properties.

**COMPOSITION:** Omega KB-6 uppers are made from a breathable pressed fabric and have leather inserts. Breathable inner lining. Anatomical insoles. They have an elasticised panel at the rear just above the heel to improve fit and allow the ankle to move freely when driving. New asymmetrical rubber soles with external lateral reinforcement. Belt closing with loop.

El botín de kart Omega KB-6 ofrece una excelente reducción del peso junto con una buena transpirabilidad.

**COMPOSICIÓN:** la pala del botín Omega KB-6 es de tejido transpirable estampado con insertos de piel auténtica. Forro interno transpirable. Plantilla interna anatómica. Refuerzo de la zona del maléolo e inserto elasticizado trasero, situado encima del talón, para mejorar el ajuste, facilitando el movimiento del tobillo mientras se conduce. Nueva suela de goma asimétrica con refuerzo lateral externo. Cierre con correa con anillo pasante.



001257...NRSI



001257...BISI



001257...RSNR



001257...NRAF



001257...AZSI

# OMEGA KB-6WP

NEW

Taglia • Size • Tamaño: 36-48

€ 145,00



**CARATTERISTICHE:** evoluzione della scarpa Omega KB-6, in versione antipioggia presenta un nuovo sistema di chiusura facilitata con cavi e rotore che permette una calzata più avvolgente ed una facile presa anche con i guanti, anche in situazioni di bagnato. La scarpa è dotata di membrana interna anatomica e resistente all'acqua.

**FEATURES:** evolution of the Omega KB-6 shoe in rain-resistant version, offers a new easy-close system with cables and a rotor to enable a more wrap-around fit and easy gripping even with gloves or in wet conditions. The shoe has an internal, water-resistant anatomical membrane.

**CARACTERÍSTICAS:** evolución del calzado Omega KB-6, en versión antilluvia, presenta un nuevo sistema de cierre facilitado con correa con anillo pasante que ofrece un calzado más envolvente y facilita el agarre también con guantes, incluso si mojado. El zapato incluye una membrana interna anatómica y resistente al agua.



001257WP..NR

# GAMMA KB-4

Taglia • Size • Tamaño: 36-48 € 69,00  
Kid Size: 26-34 € 69,00



Lo stivaletto kart Gamma KB-4 altamente resistente e traspirante grazie al tessuto in microfibra.  
**COMPOSIZIONE:** la tomaia in tessuto 3D microfibra sintetica ha un'alta resistenza all'usura ed è altamente traspirante. Inserti in pelle scamosciata. Fodera interna traspirante. Fussbett anatomico con zona di assorbimento urti nell'area del tallone. La suola dello stivaletto Gamma KB-4 è asimmetrica, studiata per rinforzare l'esterno laterale della punta e l'interno laterale posteriore, zone di appoggio, durante la guida.

Gamma KB-4 kart boots are highly resistant and breathable thanks to the use of microfibre fabric.  
**COMPOSITION:** the 3D synthetic microfibre fabric is highly wear resistant and breathable. Breathable inner lining. Anatomical insoles with impact absorption area at the heel. The soles on Gamma KB-4 boots are asymmetrical and were designed to reinforce the outer sides of the toes and the inner rear area which are used as pivot zones when driving.

El botón de kart Gamma KB-4 es sumamente resistente y transpirable gracias al tejido de microfibra.  
**COMPOSICIÓN:** la pala de tejido 3D microfibra sintética ofrece una gran resistencia al desgaste y es sumamente transpirable. Insertos de ante. Forro interno transpirable. Fussbett anatómico con zona de absorción de golpes en la zona del talón. La suela del botín Gamma KB-4 es asimétrica, estudiada para reforzar la parte externa lateral de la punta y el interior lateral trasero, zonas de apoyo, mientras se conduce.



001259...RSBI



001259...NRCE



001259...AZAF



001259...NRGF



001259...NRNR

## ACCESSORI • ACCESSORIES • ACCESORIOS

### KARTING OVERSHOES

Sovrascarpe Karting in Neoprene, sistema di chiusura a velcro con soffietto e suola in gomma naturale.  
**COMPOSIZIONE:** Neoprene 100% con rivestimento esterno in 80% Nylon + 20% Spandex. Suola in gomma naturale.

Karting overshoes in Neoprene, Velcro closure system with gusset and natural rubber sole.  
**COMPOSITION:** 100% Neoprene with external fabric in 80% Nylon + 20% Spandex. Natural rubber sole.

Sobretotas de Karting en Neopreno, sistema de cierre con velcro con fuelle y suela en caucho natural.  
**COMPOSICIÓN:** Neopreno 100% con revestimiento exterior en 80% Nylon + 20% Spandex. Suela en caucho natural.

Taglia • Size • Tamaño: S-XL

S (36-38) - M (39-41) - L (42-44) - XL (45-47)

€ 55,00



002432..N

Taglia • Size • Tamaño: S-XL

S (38,5-40) - M (40-41,5) - L (41,5-43) - XL (43,5-45)

€ 35,00



002431..N

### MANICOTTO ANTICALORE ALUMINIZED SLEEVES MANGUITO ANTICALOR

In materiale alluminizzato. Applicabile su qualsiasi tuta.  
Made from aluminized material. Suitable for any karting suit.  
Realizado en material aluminizado. Aplicable con cualquier mono.

€ 20,00



00240

KARTING

# GLOVES



SI<sup>®</sup>

# TIDE KG-9



Taglia • Size • Tamaño: 7-12

€ 110,00

Guanti a cuciture esterne con palmo preformato ergonomico ad alto grip e shock absorber. Possibilità di personalizzazione secondo guideline Sparco.

**COMPOSIZIONE:** Tessuto esterno in PA con rivestimento interno in Cotone. Palmo con rinforzi in HTX 3D "Vulcano" (brevetto Sparco).

Gloves with external seams and preformed high-grip and shock-absorber ergonomic palm. Possibility of customisation according to Sparco guidelines.

**COMPOSITION:** External fabric in PA with Cotton lining. Palm with 3D "Volcano" HTX reinforcements (Sparco patent).

Guantes con costuras exteriores con palma preformada ergonómica de gran agarre y absorción de impactos. Posibilidad de personalización según las directrices Sparco.

**COMPOSICIÓN:** Tejido exterior en PA con revestimiento interior de Algodón. Palma con refuerzos en HTX 3D "Vulcano" (patente Sparco).



00256..RS

00256..AZ

00256..NR

00256..BI

# ARROW KG-7.1 evo



Taglia • Size • Tamaño: 7-13

Kid Size: 4-6 (Black only)

€ 69,00



**COMPOSIZIONE:** esterno 100% PA, interno 100% cotone

**CARATTERISTICHE:** Precurvato. Tessuto doppio elasticizzato con fodera in cotone per miglior confort anche durante la sudorazione, più traspirante e più leggero. Il modello presenta varie innovazioni a partire dalla sagomatura ergonomica del pollice, una soluzione modellistica che permetterà di aver maggiore confort durante la guida con un conseguente miglioramento delle prestazioni. Indice sagomato per una maggiore superficie del TouchS, più sensibile anche per la regolazione del carburatore. Palma con spalmatura silconica e nuova grafica studiata per ridurre gli accumuli e mantenere una buona traspirabilità e resistenza all'abrasione dove si strofina contro il volante. Nuova grafica dorso che permette personalizzazioni da pronto

**PERSONALIZZAZIONE:** stampa transfer.

**COMPOSITION:** 100% PA outer, 100% COTTON inner

**CHARACTERISTICS:** Pre-curved. Elasticised double layer fabric in cotton for better comfort even when sweating, more breathable and lighter. The model has various novelties, starting from the ergonomic profiling of the thumb, a modelled solution that gives greater driving comfort with a consequent improvement in performance. Profiled index for larger TouchS surface, more sensitive also for adjusting the carburettor. Palm with high-grip silicone and new graphic, developed for reducing bunching and maintaining good breathability but also resistance to abrasion where it rubs against the steering wheel.

New back graphic for ready-personalisation

**PERSONALISATION:** transfer print.

**COMPOSICIÓN:** exterior 100% PA, interior 100% algodón

**CARACTERÍSTICAS:** Curvado de antemano. Tejido doble elasticizado con forro de algodón para una mayor comodidad también al sudar, más transpirabilidad y más ligero. El modelo presenta diferentes innovaciones, empezando por la forma ergonómica del pulgar, una solución de confección que ofrece una mayor comodidad al conducir con consiguiente mejora de las prestaciones. Índice formado para una mayor superficie del TouchS, más sensibles también para la regulación del carburador. Palma con recubrimiento silicónico y nuevo grafismo, estudiada para reducir las acumulaciones y mantener una buena transpirabilidad junto con resistencia a la abrasión donde se frota contra el volante. Nuevo grafismo en el dorso que permite personalizaciones.

**PERSONALIZACIÓN:** estampado transfer.



002554..RS

002554..AZ

002554..NR

002554..BI

# MOTION KG-5



Taglia • Size • Tamaño: 7-13

€ 55,00

Aree touch-screen per una maggiore sensibilità durante la guida.

**COMPOSIZIONE:** palmo con spalmatura silconica per migliorare il grip sul volante e garantire una buona traspirabilità. Pre-curvato con cuciture esterne per un ottimo fitting. Fodera con una buona permeabilità al vapore per mantenere la mano asciutta. Pollice e indice con touch-screen per una maggiore sensibilità e presa nella regolazione della carburazione e per utilizzare dispositivi elettronici. Dorso con stampa

diretta e rinforzo 3D in gomma. Puller nel polsino per agevolare la vestibilità. Rinforzo nella zona carpale del palmo per ridurre l'impatto durante l'utilizzo del cambio. Personalizzabile dal pronto.

Touch-screen areas for greater sensitivity when driving.

**COMPOSIZIONE:** high grip silicone printed palms for perfect grip of the wheel and excellent breathing properties thanks to the smooth texture which does not allow worn fabric to accumulate. Pre-curved gloves with external stitching for a perfect fit. Breathable lining keeps the hands dry. Thumb and index finger with touch-screen areas for improved sensitivity and grip

when adjusting carburetion and for using electronic devices. Direct printed backs and 3D rubber reinforcements. Pullers at wrists to facilitate dressing. Reinforcement at the carpal region to reduce impact damage during gear changes. Can be personalised from stock.

Zonas touch-screen para ofrecer una mayor sensibilidad mientras se conduce.

**COMPOSICIÓN:** palma con embadurnamiento silicónico, estudiado para mejorar el agarre del volante y garantizar una buena transpirabilidad. Guante curvado de antemano con costuras externas para un excelente ajuste. Forro con una buena permeabilidad al vapor para mantener la mano seca. Pulgar e índice realizados con parte touch-screen para tener una mayor sensibilidad y agarre para la regulación de la carburación y para utilizar dispositivos electrónicos. Dorso con estampado directo y refuerzo 3D de goma. Puller en la zona de la muñeca para ponerlo fácilmente. Refuerzo en la parte carpal de la palma para reducir el impacto al utilizar el cambio. Personalizable partiendo del producto listo.



002552..AZ

002552..GF

002552..NR

002552..RS

# MOTION KG-5WP

NEW



Taglia • Size • Tamaño: 7-13

€ 65,00

**CARATTERISTICHE:** evoluzione del guanto Kart MOTION KG-5, pre curvato, con cuciture esterne per il massimo confort. Palmo con spalmatura silconica per migliorare il grip sul volante, con imbottitura e cucitura di rinforzo. Feeling avvolgente, fodera in morbido pile antigelo con membrana anti-pioggia e cuciture termosaldate.

**FEATURES:** evolution of the Kart MOTION KG-5 glove, pre-curved with external seams for maximum comfort. Palm with silicone coating for improved grip on the steering wheel, with padded and stitched reinforcement. Wrap-around feel, soft anti-freeze fleece lining with rain-resistant membrane and heat-sealed seams.

**CARACTERÍSTICAS:** evolución del guante para Kart MOTION KG-5, curvado de antemano, con costuras externas para ofrecer el máximo confort. Palmo con embadurnamiento silicónico para mejorar el agarre del volante, con acolchado y costura de refuerzo. Sensación envolvente, forro de polar suave antihielo con membrana anti-luvia y costuras termosoldadas.



002552WP..NR

# TRACK KG-3



Taglia • Size • Tamaño: 7-13

Kid Size: 4-6

€ 35,00

Il guanto kart Track KG-3 è realizzato con cuciture interne e stampa silconica ad alto grip.

**COMPOSIZIONE:** tessuto elasticizzato con palmo in materiale combinato: pelle sintetica scamosciata con stampa silconica con un'ottima resistenza all'abrasione. Le zone di stampa sono studiate per migliorare il grip con il volante. Inserimento di soffietti tra le dita per dare una maggiore traspirazione. Puller in pelle scamosciata per agevolare la vestibilità. Elastico nella zona polso per migliorare il fitting. Personalizzabile dal pronto.

Track KG-3 kart gloves feature internal stitching and high grip silicon printed palms.

**COMPOSIZIONE:** elasticised fabric with palms in combined material: synthetic suede with printed silicone for excellent scuff resistance. The printed areas were specifically designed to improve grip of the steering wheel. Pads between the fingers provide better breathing. Suede pullers to facilitate dressing. Elasticised wrists for a perfect fit. Can be personalised from stock.

El guante de kart Track kg-3 se realiza con costuras internas y estampado silicónico de alto agarre.

**COMPOSICIÓN:** tejido elasticizado con palma de material combinado: piel sintética agamuzada con estampado silicónico con una excelente resistencia a la abrasión. Las zonas de estampado han sido estudiadas para mejorar el agarre del volante. Fuelles entre los dedos para ofrecer una mayor transpirabilidad. Puller de ante para ponerlo fácilmente. Elástico en la zona de la muñeca para mejorar el ajuste. Personalizable partiendo del producto listo.



002553..AZAF



002553..VF



002553..NR



002553..RS

# CRW

Taglia • Size • Tamaño: S-XL

Kid Size: XXS-XS

€ 35,00

Guanti in Neoprene con cuciture termosaldate e palmo preformato ergonomico ad alto grip.

**COMPOSIZIONE:** Neoprene 100% con rivestimento esterno in 80% Nylon + 20% Spandex e rivestimento interno in 100% Poliestere.

Gloves in Neoprene with thermal welded seams and preformed high-grip ergonomic palm.

**COMPOSITION:** 100% Neoprene with external fabric in 80% Nylon + 20% Spandex and 100% polyester lining.

Guantes en Neopreno con costuras termosoldadas y palma preformada ergonómica de gran agarre.

**COMPOSICIÓN:** Neopreno 100% con revestimiento exterior en 80% Nylon + 20% Spandex y revestimiento interior 100% Poliéster.



00258NR..



KARTING

# HELMETS



ISI<sup>®</sup>

# AIR KF-7W CARBON



Il casco AIR KF-7W è realizzato con calotta in carbonio rinforzata con strati in carbon-kevlar. La calotta e i polistiroli sono in doppia misura, progettati e costruiti per garantire il massimo livello di ventilazione. Gli interni del casco sono smontabili, riposizionabili e lavabili. Il casco AIR KF-7W è predisposto per accogliere il drink system mentre la visiera (omologata FIA) è a regolazione continua. Disponibile in 6 taglie.

The AIR KF-7W helmet has a carbon fibre shell reinforced with layers of carbon-Kevlar. The shell and EPS are manufactured in two sizes and has been designed to ensure excellent ventilation. The interior linings can be removed, washed and repositioned. The AIR KF-7W helmet can accommodate a drink system and the visor (FIA approved) can be constantly adjusted. Available in 6 sizes.

El casco AIR KF-7W tiene calota de carbono reforzada con capas de carbon-kevlar. La calota y los rellenos de poliestireno son en doble medida, diseñados y realizados para garantizar el máximo nivel de ventilación. Los elementos internos del casco son desmontables, recolocables y lavables. El casco AIR KF-7W está preparado para acoger el drink system mientras que la visera (homologada FIA) se puede ajustar continuamente. Disponible en 6 tallas.

Homologation: SNELL K 2015

CARBON

€ 695,00



	CARBON
XS	53-54 0033540XS
S	55-56 0033541S
M	57-58 0033542M
M+	59 0033543ML
L	60 0033544L
XL	61 0033545XL

# SKY KF-5W



Il casco AIR PRO RF-5W è realizzato con calotta in vetroresina rinforzata con strati carbon-kevlar. La calotta e i polistiroli sono in doppia misura, progettati e costruiti per garantire il massimo livello di ventilazione. Gli interni del casco sono smontabili, riposizionabili e lavabili. Il casco AIR PRO RF-5W è predisposto per accogliere il drink system mentre la visiera (omologata FIA) è a regolazione continua. Il casco AIR PRO RF-5W è fornito con clip Hans® già installate. Disponibile in 7 taglie e due differenti colori.

The AIR PRO RF-5W helmet has a carbon fibre shell reinforced with layers of carbon-Kevlar. The shell and EPS are manufactured in two sizes and have been designed to ensure excellent ventilation. The interior linings can be removed, washed and repositioned. The AIR PRO RF-5W helmet can accommodate a drink system and the visor (FIA approved) can be constantly adjusted. The AIR PRO RF-5W comes supplied with Hans® clips fitted. Available in 7 sizes and in two colours.

El casco AIR PRO RF-5W tiene calota de fibra de vidrio reforzada con capas de carbon-kevlar. La calota y los rellenos de poliestireno son en doble medida, diseñados y realizados para garantizar el máximo nivel de ventilación. Los elementos internos del casco son desmontables, recolocables y lavables. El casco AIR PRO RF-5W está preparado para acoger el drink system mientras que la visera (homologada FIA) se puede ajustar continuamente. El casco AIR PRO RF-5W lleva clips Hans® ya instalados. Disponible en 7 tallas y dos colores diferentes.

Homologation: SNELL K 2015

KEVLAR/FIBERGLASS

€ 395,00



	WHITE	MATT BLACK
XS	53-54 0033550XS	XS 53-54 0033550XSNR
S	55-56 0033551S	S 55-56 0033551SNR
M	57-58 0033552M	M 57-58 0033552MNR
M+	59 0033553ML	M+ 59 0033553MLNR
L	60 0033554L	L 60 0033554LNR
XL	61 0033555XL	XL 61 0033555XLNR
XXL	62 0033556XXL	XXL 62 0033556XXLNR



# GP KF-4W CMR

Homologation: SNELL CMR 2016

CARBON KEVLAR

€ 395,00



XS	54-55	0033580XS
S	56	0033581S
M	57-58	0033582M
L	59	0033583L



Il nuovo casco CMR rispetta la nuova normativa CMR2016, più restrittiva della precedente. La calotta in carbon kevlar garantisce sicurezza e leggerezza. Il nuovo casco CMR è compatibile con tutti gli accessori Sparco per caschi integrali.

The new CMR helmet complies with new standard CMR2016, which is stricter than the preceding standard. The carbon Kevlar cap guarantees safety and lightness. The new CMR helmet is compatible with all Sparco accessories for full-face helmets.

El nuevo casco CMR respeta la nueva normativa CMR2016, más restrictiva que la anterior. El casquete de carbono kevlar garantiza seguridad y ligereza. El nuevo casco CMR es compatible con todos los accesorios Sparco para cascos integrales.



CLUB X1

> PAGE 000



CLUB J-1

> PAGE 000



HELMET BAGS

> PAGE 000

ACCESSORI CASCHI • HELMETS ACCESSORIES > PAGE 000

# COLLARI SUPPORTO CASCO - NECK SUPPORT COLLARS COLLARÍN SOPORTE CASCO

€ 45,00



Caratterizzato dalla particolare forma anatomica posteriore e dall'imbottitura a densità differenziata (più consistente nelle zone di appoggio del casco e più morbida sotto il mento e nello spoiler) per attenuare il peso del casco sulla schiena.

Characterized by a special rear anatomic shape and variable density padding (more consistent in the helmet support area and softer under the chin and in the spoiler) in order to reduce the weight of the helmet on the back.

Caracterizado por su particular forma anatómica de la parte de atrás y por el mullido de densidad diferenciada (más consistente en las zonas de apoyo del casco y más suave en la parte del mentón y en el spoiler) para atenuar el peso del casco en la espalda.



001602AZNR-B

001602RSNR-B

001602GRNR-B



HELMETS

271

PREZZI IVA ESCLUSA  
VAT NOT INCLUDED • PRECIOS SIN IVA

PREZZI IVA ESCLUSA  
VAT NOT INCLUDED • PRECIOS SIN IVA

KARTING

270

# KG320

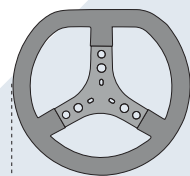

320



Flat

Diametro 320 mm. I volantini hanno anima e razza in alluminio anticorrosivo, con saldature TIG. Impugnatura ergonomica, rivestiti in vera Alcantara®.

Diameter 320 mm. The steering wheels have anticorrosive aluminium hub and spoke, with TIG welding. Ergonomic grip, clad in real Alcantara® suede.

320 mm de diámetro. Los volantes tienen núcleo y radios de aluminio anticorrosivo, con soldaduras TIG. Agarre ergonómico, revestidos en alcántara.

Scamosciato - Suede - Ante € 115,00

0158KG320NR

# KG345

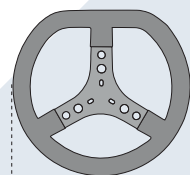

345



Flat

Diametro 345 mm. I volantini hanno anima e razza in alluminio anticorrosivo, con saldature TIG. Impugnatura ergonomica, rivestiti in vera Alcantara®.

Diameter 345 mm. The steering wheels have anticorrosive aluminium hub and spoke, with TIG welding. Ergonomic grip, clad in real Alcantara® suede.

345 mm de diámetro. Los volantes tienen núcleo y radios de aluminio anticorrosivo, con soldaduras TIG. Agarre ergonómico, revestidos en alcántara.

Scamosciato - Suede - Ante € 125,00

0158KG345NR

## MANOMETRO - TYRE PRESSURE GAUGE MANÓMETRO PRESIÓN PNEUMÁTICOS

Ø 100 mm

Scala 0 - 2,5 Bar, manopola in alluminio, calotta in gomma, grande precisione di rilevamento e facilità di lettura.  
Scale 0 - 2,5 bar, aluminium handle, rubber cap, high-precision recording.

Escala 0 - 2,5 bar, manecilla de aluminio, calotas de goma, gran precisión de detección y facilidad de lectura.

€ 155,00



29424102C

## BORSA PORTA GOMME - TIRE BAG BOLSA PARA NEUMÁTICOS

Leggera e molto resistente. Colore: azzurro.  
Light and strong. Color: blue

Ligera y muy resistente. Color: azul.

€ 29,00



02719AZ

## PROTEZIONI ADESIVE PER SEDILI ADHESIVE PROTECTION FOR SEATS PROTECCIONES ADHESIVAS PARA LOS ASIENTOS

Adattabili a tutti i tipi di sedili. nuova densità più morbida.  
Color: nero.

Adaptable to any type of seat. new density, softer.

Color: black.

Se adaptan a todos los tipos de asientos. nueva densidad más suave. Color: negro.

€ 35,00



02798

## COPRIKART - KART COVER FUNDA CUBREKART

Professionale, molto ampio per ogni tipo di kart, con sagomatura per il volante, completo di custodia. Bicolore argento/azzurro e argento/rosso.

Professional, very wide to suit any type of kart, with outline for the steering wheel, case included. Two colors, silver/blue and silver/red.

Profesional, muy amplia para todo tipo de kart, con forma para el volante y bolsa. Disponible en dos combinaciones bicolor: plata/azul y plata/rojo.

€ 55,00



02712R

02712A

# TELEMETRY

# TRACKMATE

## PERFORMANCE TRACKING SYSTEM

Trackmate é uno strumento professionale di rilevazione, monitoraggio e misurazione dati di telemetria. Con Trackmate non ci sono limiti, tranne i tuoi! Migliora le tue performance e batti i tuoi tempi in modo facile e veloce. Scarica la app dal tuo smartphone, registrati e comincia ad usare Trackmate, il tuo nuovo alleato nella misurazione delle tue prestazioni.

Trackmate is a professional tool for the detection, monitoring and measurement of telemetry data. With Trackmate there are no limits, except yours! Improve your performances and beat your times quickly and easily. Download the app from your smartphone, register and start using Trackmate, your new ally in measuring your performance.

Trackmate es un instrumento profesional de recogida, seguimiento y medición de datos de telemetría. Con Trackmate no hay límites, isalvo los tuyos! Mejora tus resultados y baja tus tiempos de una forma fácil y rápida. Descarga la App en tu smartphone, regístrate y empieza a utilizar Trackmate, tu nuevo aliado para medir tus prestaciones.

€ 399,00



- **REPLAY** YOUR SESSION
- **ANALYSE** YOUR DATA
- **BEAT** YOUR TIME

PERFORMANCE

# SEATS



ISI<sup>®</sup>

# SPX



## L'avanguardia dei sedili sportivi

Il sedile SPX è prodotto artigianalmente in Italia con la stessa tecnologia e gli stessi materiali utilizzati per le supercar OEM. SPX è il primo sedile reclinabile in fibra di carbonio conforme alle stesse specifiche imposte ai produttori OEM. Il sedile SPX è realizzato in fibra di carbonio e materiali compositi che garantiscono comfort ed elevate prestazioni con un'estrema leggerezza. Il sedile SPX è rivestito in pelle prodotta in Italia. La parte centrale del sedile SPX è rivestita in Alcantara®, per garantire il controllo perfetto del veicolo e l'esperienza di guida più entusiasmante. Il tocco estetico finale è rappresentato dalle cuciture realizzate a mano, di colore nero, perfettamente intonate con il logo ricamato Sparco. Lo schienale è dotato di una manopola che consente la regolazione millimetrica per garantire una posizione di guida perfetta. Il sedile SPX è disponibile in versione conducente e passeggero (sinistro e destro).

## The ultimate evolution of the sport seats

The SPX is handcrafted in Italy using the same technology and materials used for OEM super cars. In fact the SPX is the first Carbon Fiber reclining seat available to the public that meets the same specifications required by the OEM manufacturers. The SPX uses a combination of carbon fiber and advanced composites that give the driver both comfort and performance in a lightweight package. The SPX is covered in a combination of beautiful smooth Italian leather. The center of the SPX is covered in Alcantara® suede to allow you to gain absolute control of your vehicle and enhance your driving experience. To finish off the performance look, all hand stitching is done in tone-on-tone black with the Sparco logo embroidered in matching black. The backrest also features a micro adjustment knob that allows you to dial in the perfect driving position. The SPX is sold in driver and passenger versions (left and right).

## La evolución suprema de los asientos deportivos

El SPX es fabricado artesanalmente en Italia, utilizando la misma tecnología y los mismos materiales utilizados para los OEM de los supercoches. Efectivamente el SPX es el primer asiento abatible en fibra de carbono a la disposición del público que cumple las mismas especificaciones exigidas por los fabricantes OEM. El SPX utiliza una combinación de fibra de carbono y materiales compuestos avanzados que ofrecen al conductor comodidad y rendimiento en un conjunto ligero. El SPX está revestido con una combinación de estupenda piel italiana y suave. El centro del SPX está revestido en Alcantara® que permiten mantener el control absoluto del vehículo y mejorar la experiencia de conducción. Para rematar el aspecto deportivo, todo el cosido manual ha sido realizado en tono sobre tono negro con el logotipo Sparco bordado en el mismo color negro. El respaldo dispone de un puño de microajuste que permite obtener la posición de conducción perfecta. El SPX se vende en las versiones conductor y pasajero (izquierda y derecha).

€ 2.500,00



00974ZNRSX

00974ZNRDX

**NEW**

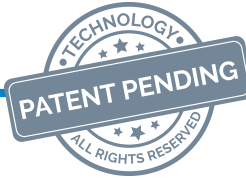

# QRT-PERFORMANCE

Scocca in taglia L, progettata utilizzando i più innovativi software CAD. Nuovo design anche per la mostrina passa cintura. Questa scocca è facilmente installabile anche negli abitacoli più angusti.

€ 1.285,00

L size shell, designed with the state-of-the-art CAD software. New design also for the seat belt slider. This shell is easily installable, also in the smallest of cockpits.

Bastidor en talla L, diseñado mediante el software CAD más innovador. Divisa para el cinturón también con nuevo diseño. Este bastidor es fácil de instalar incluso en los habitáculos más estrechos.



MANUFACTURER: SPARCO  
MODEL: QRT-V  
HOM. NO: CS.378.17  
FIA STANDARD: 8855-1999



€ 110,00

0049616QRT



008006RNR

# R600

Telaio tubolare in acciaio. Nuova regolazione micrometrica dello schienale derivata dal primo impianto delle più prestigiose supercar. Rellenos ergonomicos con elevado confort. Fundas: Jacquard. Palanca para volcar el respaldo. Fijación inferior 271x345. Compatible con cinturones deportivos. de 3 y 4 puntos de fijación.

€ 715,00

Tubular steel frame. New micro seat back regulation, similar to top supercars. Ergonomic and comfortable padding. Covering: Jacquard. Quick tilting lever. Lower fixing 271x345. Compatible with 3 and 4 points safety harnesses.

Estructura tubular en acero. Nuevo ajuste micrometrico del respaldo derivado de la experiencia con los más prestigio-

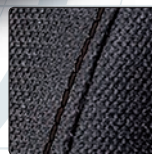
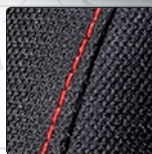

00968NRRS

00968NRNR

# R333

Telaio tubolare. Doppia leva regolazione e ribaltamento rapido. Fissaggio inferiore 271 x 345. Compatible con cinture sportive a 3 e 4 punti.

€ 415,00

Tubular frame. Double adjustment and reclining lever. Bottom fixing (271 x 345). Compatible with 3 or 4 fixing point harnesses.

Marco tubular. Doble ajuste y palanca de inclinación. Fijación inferior (271x345). Compatible con cinturones deportivos de 3-4 puntos.



00965NRGRS

00965NRGR

00965NR

PREZZI IVA ESCLUSA  
VAT NOT INCLUDED - PRECIOS SIN IVA

# F200

Monoscocca tubolare in acciaio. Fissaggio 271x345. Compatibile con cinture sportive. 3 e 4 punti di fissaggio. Tessuto 3D per maggiore traspirabilità.

Tubular steel frame chassis. Fixing points 271x345. Compatible with 3 and 4 points safety harnesses. 3D fabric for improbe breathability.

Estructura tubular en acero. Fijación 271x345. Compatible con cinturones deportivos de 3 y 4 puntos de fijación. Tejido en 3D para una mayor transpiración.

€ 280,00



00917RS



00917AZ



00917NR

# R100 / R100 SKY

Monoscocca tubolare in acciaio. Fissaggio 271x345. Compatibile con cinture sportive. 3 e 4 punti di fissaggio. Tessuto 3D per maggiore traspirabilità.

Tubular steel frame chassis. Fixing points 271x345. Compatible with 3 and 4 points safety harnesses. 3D fabric for improbe breathability.

Estructura tubular en acero. Fijación 271x345. Compatible con cinturones deportivos de 3 y 4 puntos de fijación. Tejido en 3D para una mayor transpiración.



R100

€ 275,00

R100 SKY

€ 295,00

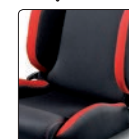

00961NRRS

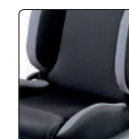

00961NRGR

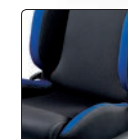

00961NRAZ

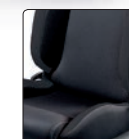

00961NRNR

00961NRSKY

PREZZI IVA ESCLUSA  
VAT NOT INCLUDED - PRECIOS SIN IVA

SEATS

285

PERFORMANCE

284



## BASI, GUIDE E ADATTATORI PER MONTAGGIO SEDILI SEAT SLIDES, SUBFRAMES FOR BOTTOM MOUNTING BASES, CORREDERAS Y ADAPTADORES



€ 88,00

**BASE ADATTATORE**  
per sedili racing su guide scorrevoli.  
**ADAPTOR** for racing seats on seat rails  
**BASE ADAPTADORA**  
para asientos Racing con guías deslizantes

00497RACE



**Esempio di base specifica.** Per la lista applicazioni completa consultare il listino.  
**Example of specific frame.** For the complete application list see the price list.  
**Ejemplo de base específica.** Para ver la lista completa de aplicaciones rogamos consulten la tarifa de precios.



**SERIE GUIDE**  
Interasse longitudinale 271 mm  
**SET OF SLIDE RUNNERS**  
Longitudinal distance 271 mm  
**JUEGO DE CORREDERAS**  
Entreeje 271 mm

0049302 Economical  
€ 35,00

00493 Top quality  
€ 70,00



€ 82,00

**KIT MONTAGGIO UNIVERSALE**  
composto da 4 staffe con regolazioni in altezza, 2 profili angolari in alluminio rinforzati e le necessarie viterie.  
**UNIVERSAL FITTING KIT**  
with 4 brackets with height adjustment, 2 reinforced aluminium corner pieces and the necessary screws and nuts.  
**KIT DE MONTAJE UNIVERSAL**  
compuesto por 4 pletinas con regulación de altura, 2 ángulos reforzados en aluminio y la tornillería.

00495

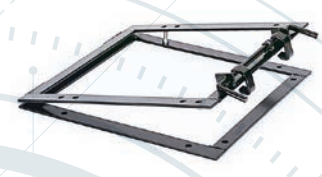

€ 162,00

**STAFFA DI RIBALTAMENTO**  
da interporre tra base e guide, per consentire l'accesso ai posti posteriori su vetture a due porte anche in caso di sedili a schienale fisso.  
**TILT FORWARD BRACKET**  
to be fitted between slides and subframes to allow easy access to the rear seats also on cars with front seats with fixed backrest.  
**SOPORTE ABATIBLE**  
para intercalar entre la base y las correderas, para permitir el acceso a los asientos traseros con coches de dos puertas en caso de asientos con respaldo fijo.

00494

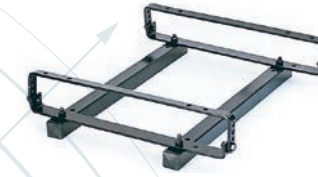

€ 78,00

**BASE UNIVERSALE**  
con sistema di regolazione in altezza del sedile, per vetture con guide scorrevoli di serie sbullonabili dal sedile originale. Interasse guide fino a 430 mm.  
**UNIVERSAL SUBFRAME**  
with mechanism to adjust the height of the seat, for cars with removable slides from the original seat with distance between slides up to 430 mm.  
**BASE UNIVERSAL**  
con sistema de regulación en altura del asiento. Puede montarse en vehículos en los cuales el avance del asiento original se realiza a través de guías correderas que pueden desatornillarse del asiento original y que tienen un entreeje hasta 430 mm.

00491

## MISURE SEDILI

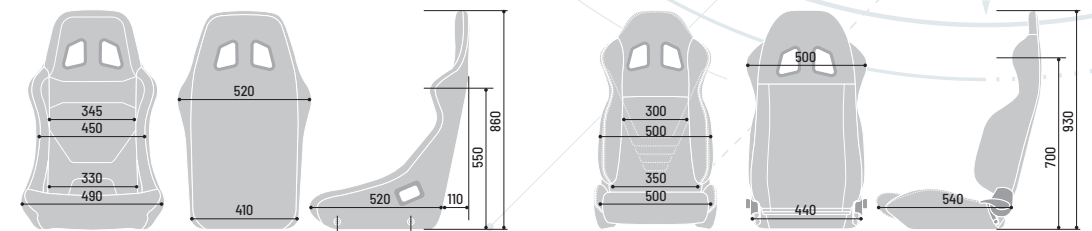
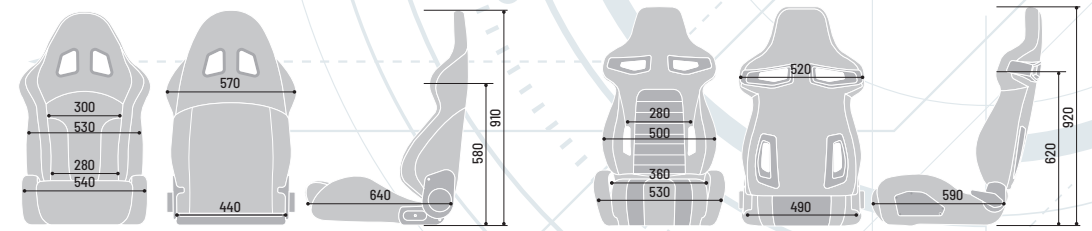
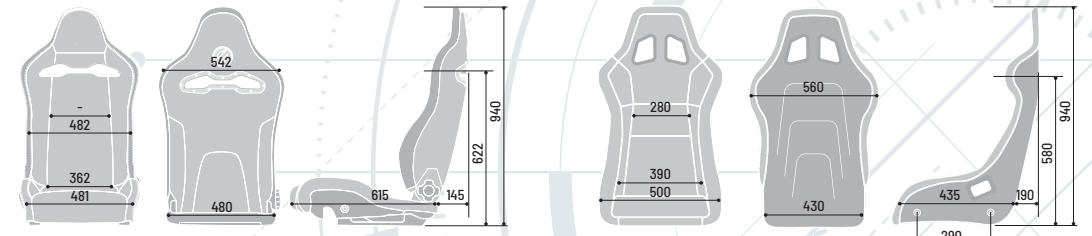

# PERFORMANCE

# HARNESSES



## 04604 BM1

Cintura a 4 punti con rinforzo ventrale e fissaggio a moschettone.  
4 fixing points, snap on, lap reinforcement.

4 puntos de fijación, con refuerzo en las piernas y boche de cierre.  
4 fixing points, snap on, lap reinforcement.

Homologation: ECE

€ 109,00



04604BM1RS

04604BM1GR

04604BM1AZ

04604BM1NR

## 04608 DF1

Cintura a 3 punti con rinforzo ventrale e fissaggio a moschettone, doppia fibbia per sgancio posteriore.  
3 fixing points, double buckle, snap on and lap reinforcement.

3 puntos de fijación con refuerzo en las piernas, doble hebilla y broche de cierre.  
3 fixing points, double buckle, snap on and lap reinforcement.

Homologation: ECE

€ 89,00



04608DF1RS

04608DF1GR

04608DF1AZ

04608DF1NR

# 04604 BV1

Cintura 4 punti con rinforzo ventrale e fissaggio a vite.  
4 fixing point by bolt with lap reinforcement.

4 puntos de fijación por tornillo con refuerzo en las piernas.

Homologation: ECE

€ 86,00



04604BV1RS

04604BV1GR

04604BV1AZ

04604BV1NR

# SPORT

Sottile. Thin. Delgado.

€ 22,00



01090S4AZ

01090S4RS

01090S4NR

# 77

Sottile. Thin. Delgado.

€ 18,00



0109077BIAZ

0109077AZ

0109077RS

0109077NR

# 04608 BV1

Cintura a 3 punti, fissaggio a vite.

3 bolted fixing points.

3 puntos de fijación a tornillo.

Homologation: ECE

€ 83,00



04608BV1RS

04608BV1GR

04608BV1AZ

04608BV1NR

# GT

Sottile. Thin. Delgado.

€ 27,00



01090R3AZ

01090R3RS

01090R3NR

# MINI

Coppia di cuscinetti in Alcantara® con all'interno neoprene ad alto grip. Utilizzabile per una migliore e più comoda presa sui volantini e sulle impugnature delle leve freno a mano.

Pair of pads in Alcantara® with high grip neoprene inner layer. Useful to improve comfort of driving when fitted on steering wheels or handbrake handle.

Juego de almohadillas pequeñas con interior de neopreno que asegura una máxima adherencia. Se pueden utilizar sobre el volante y la empuñadura de freno de mano.

€ 15,00



01099NR

01099RS

01099AZ

PERFORMANCE

# STEERING WHEELS



ISI<sup>®</sup>

# TARGA 350

NEW

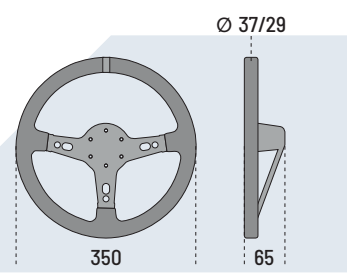

Pelle liscia - Leather - Piel € 195,00

015TARGA350PLNR

# CHAMPION

NEW

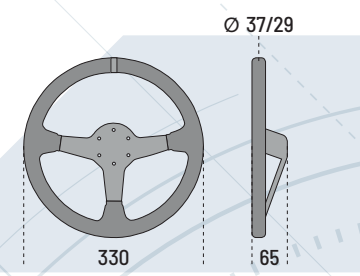

Pelle liscia - Leather - Piel € 185,00

015R330CHAMPION

# R383 CHAMPION

NEW

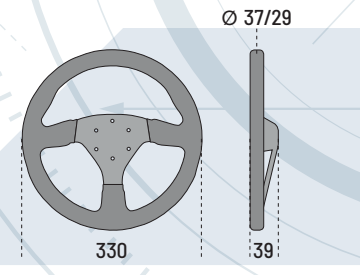

Pelle liscia - Leather - Piel € 185,00

015R383PLUNRS

Pelle liscia - Leather - Piel € 185,00

015R383PLUNNR

PREZZI IVA ESCLUSA  
VAT NOT INCLUDED - PRECIOS SIN IVA

PREZZI IVA ESCLUSA  
VAT NOT INCLUDED - PRECIOS SIN IVA

PERFORMANCE

STEERING WHEELS

# L777

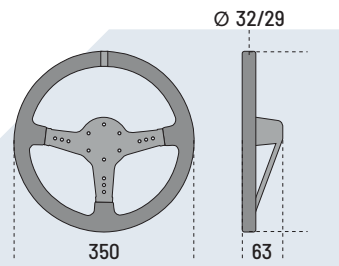

Pelle liscia - Leather - Piel € 250,00

015L800PL



Scamosciato - Suede - Ante € 250,00

015L800SC

# L575

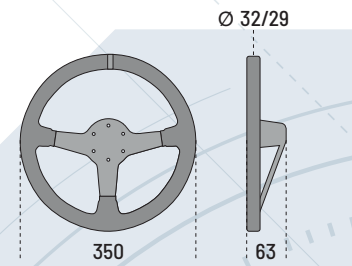

Pelle liscia - Leather - Piel € 246,00

015L750PL



Scamosciato - Suede - Ante € 239,00

015L750SC

# L550

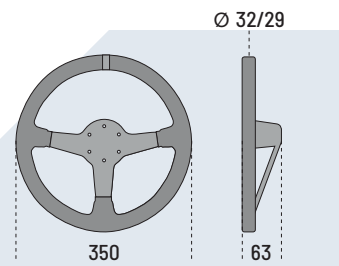

Pelle liscia - Leather - Piel € 240,00

015TMZL9



Scamosciato - Suede - Ante € 240,00

015TMZS1

# L505

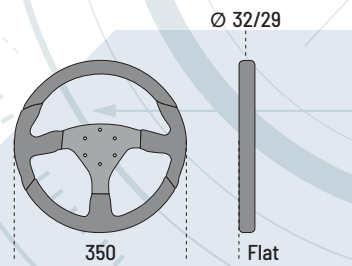

Pelle liscia - Leather - Piel € 240,00

015TL522TUV

PREZZI IVA ESCLUSA  
VAT NOT INCLUDED - PRECIOS SIN IVA

STEERING WHEELS

PERFORMANCE

# L360

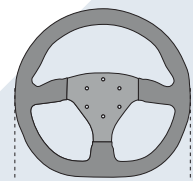

Ø 37/28



330

Flat



Pelle liscia - Leather - Piel € 253,00

015TRGL1TUV

Scamosciato - Suede - Ante € 236,00

015TRGS1TUV

# P222

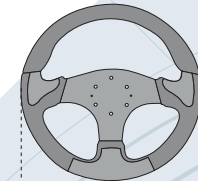

Ø 35/28



345

Flat



Poliuretano - Polyurethane - Black/Silver € 118,00

015THPUGR345

Poliuretano - Polyurethane - Black/Silver € 118,00

015THPUNR345

# L999

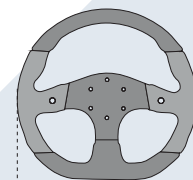

Ø 36/28



330

Flat

Pelle/Scamosciato - Leather/Suede - Piel/Ante € 273,00

015TMG22TUV



PREZZI IVA ESCLUSA  
VAT NOT INCLUDED - PRECIOS SIN IVA

PERFORMANCE  
STEERING WHEELS

## Mozzi Hub Cubos para volantes

I mozzi sparco collassabili sono costituiti da una fusione in ghisa e da un telaio in acciaio che letteralmente collassa in caso d'urto garantendo l'assorbimento dell'energia cinetica non trasferendola al pilota.

**I volanti sparco sono omologati TUV esclusivamente se abbinati ai mozzi Sparco.**

Sparco collapsible hubs are cast iron made with a steel frame that collapse during impacts. This item absorbs kinetics energy avoiding transfer to the driver.

**The Sparco steering wheels are TUV approved only if coupled with the Sparco hubs.**

Los adaptadores Sparco son colapsable y están compuestos por un chasis de fundición de acero que en caso de impacto absorbe la energía cinética evitando que se transmita al piloto.

**Los volantes Sparco cumplen la homologación TUV solo si están montados conjuntamente con los adaptadores Sparco.**

## Mozzetti a sgancio rapido Quick release steering bosses Cubos del volante con desenganche rápido

In alluminio con anima dentata in acciaio fresato a CNC. Sistema universale di montaggio per volanti a 3 o 6 fori con possibilità di fissaggio su piantone sterzo (a mezzo saldatura) o su mozzo specifico vettura.

CNC machined with steel spline. Black anodized and orange. Universal fixing system for 3 or 6 fixing point, steering hub, steering column.

En aluminio con alma de acero dentada. Mecanizado CNC. Sistema universal de montaje para volante de 3 o 6 agujeros con posibilidad de montar en la columna de dirección o en un hub específico de coche.

€ 375,00



015R98TU

PER LA LISTA APPLICAZIONI CONSULTARE IL LISTINO.  
FOR THE APPLICATION LIST PLEASE CHECK PRICE LIST.  
PARA LA LISTA DE LAS APLICACIONES,  
CONSÚLTASE EL LISTIN.

## Kit pulsanti corsa Racing push buttons kit Kit botones de pulsación

Supporti anodizzati nero con pulsanti  
Black anodized supports with push buttons  
Soporte negro anodizado con botones de pulsación

€ 35,00

€ 49,00



015NE981

015NE982

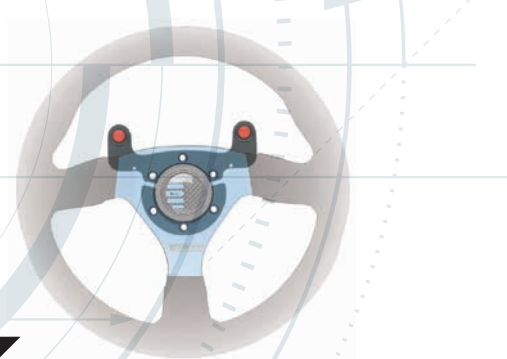

## Distanziali anodizzati per volanti Anodized steering wheel spacers Distanciadores anodizados de volante

€ 75,00



01595ANR

01595ANT

## Ghiere Ring Aro

Alluminio anodizzato - Anodized aluminium - Aluminio anodizado

€ 33,00



01599NR

## Gemme pulsante clacson Center caps for horn button Pulsadores de claxon

Serie 10 gemme per pulsanti Sparco con marchio  
Set of 10 center caps for Sparco horn buttons  
Set de 10 piezas tapas para botones de claxon con logo

€ 49,00 (10 PCS)



01597GZ

01597GN

01597GG

01597GR



PERFORMANCE

# PEDAL SETS GEAR KNOB



SI®

## PIUMA

Pomello alleggerito grigio/nero opaco.  
Lightened grey/black gear knob.  
Pomo ligero gris/negro opaco.



€ 55,00 € 55,00

03741BN01 03741BT01

## SETTANTA

Pomello bicolore titanio/nero opaco.  
Titan/black two colour gear knob.  
Pomo bicolore titanio/negro opaco.



€ 54,00 € 48,00

03736A 03736A01

## RACING

Montaggio universale su aste cambio con diam. max 15 mm. Non adatto per cambio con inibitore a siringa. Alluminio.  
Universal mounting on all gear stick with a max diam. 15 mm. Not suitable for gearbox with syringe safety stop. Made by aluminium.  
Montaje universal en todas las palancas de cambio hasta un diám. max 15 mm. No es adecuado para palanca de cambio hidráulica. Aluminio.



€ 53,00 € 49,00 € 48,00

037401CL 037401AN 037401CR

## SPEED

Pomello cromato con boccia rivestita in pelle.  
Chromed gear knob with leather insert.  
Pomo cromado con buje en piel.



€ 72,00

03744PTN

## TRALICCIO

Pomello forato con impugnatura a sfera.  
Drilled gear knob with sphere handgrip.  
Pomo perforado con empuñadura esférica.



€ 48,00

03740TR

## SETTANTA R

Pomello bicolore titanio/nero opaco per cambio a siringa.  
Titan/black two colour gear knob for reverse gear.  
Pomo bicolore titanio/negro opaco. Marcha atrás de gatillo.

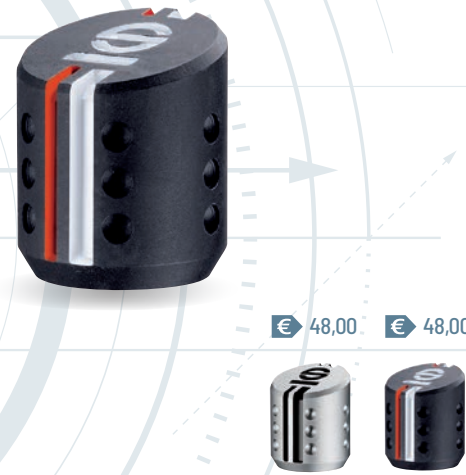

€ 48,00 € 48,00

03737TS 03737NS

## TECNO

Pomello cromato o rivestito in pelle traforata.  
Chromed or wrapped in perforated leather gear knob.  
Pomo cromado o revestido en piel.



€ 60,00 € 60,00

03747PTN 03747CR

## GLOBE

Cromato con boccia rivestita in pelle per cambio a siringa.  
Chromed gear knob with leather insert for reverse gear.  
Pomo cromado con buje en piel para coches con marcha atrás de gatillo.



€ 66,00

03745PTN

# REFLEX

Serie pedali Reflex universale, ECE  
Reflex kit universal pedals, ECE.  
Juego. Pedales Reflex. Universal. ECE.

Homologation: ECE

€ 42,00

Set gommini - Rubber kit - Set de gomas

●●●●● € 29,00

03787K13



0378713

PoggiapiEDE pilota lucidato  
Driver footrest in shiny aluminium  
Reposapiés conductor en aluminio brillante

€ 43,00

03788BRI



# PIUMA

Set pedali, universale.  
Set of universal pedals.  
Juego pedales, universal.

Homologation: ECE

€ 43,00



037879BT01



037879BC01

# SETTANTA

Pedale alleggerito nero o silver, universale.  
Lightened universal black or silver pedal.  
Pedales ligero negro o silver, universal.

Homologation: ECE

€ 44,00



037879IT01

Set pedali con acceleratore a soletta.  
Set of pedals, long accelerator pedal.  
Juego pedales, pedal acelerador largo.

€ 44,00



0378790P04



0378790P01

Leva freno a mano universale  
Universal handbrake  
Freno de mano universal.

€ 47,00



03753TI



03753NR

# DRIFTING

## Hydraulic brake lever

Leva freno a mano idraulica compatibile con Pompa freno e accessori Girling. Possibilità di uso in orizzontale o verticale grazie alla regolazione con uniball. Tubo Ø 20 mm. Vendita singola. **Coprileva, uniball e sistema Girling non inclusi.**

Hydraulic brake lever, Girling compatible. Horizontal or vertical fitting (uniball adjusting). 20 mm tube. Black. Sold individually. **Lever cap, uniball and Girling system not included.**

Palanca de freno de mano compatible con la bomba de frenos hidráulicos y accesorios Girling. Se puede utilizar horizontal o verticalmente ajustando con uniball. Tubo Ø 20 mm. Venta individualmente. **Cubre palanca, uniball y sistema Girling no incluidos.**

€ 110,00



## Hand brake lever

Impugnatura in alluminio per leva freno a mano. Realizzata in alluminio con inserti o-ring antiscivolo. Regolabile in altezza altezza fino a +15 cm. Con di viti di fissaggio e istruzioni. Diametro imbocco 20 mm.

Aluminum hand brake lever. Black aluminum tube, with anti-slip o-ring. Height adjusting up to +15 cm with additional part. Complete with screws and instructions. Fitting diameter: 20 mm.

Mango de aluminio para la palanca del freno de mano. Tubo de aluminio negro con junta tórica antideslizamiento. Regulables en altura hasta +15 cm por medio de anillo contra roscado. Tornillos de montaje e instrucciones. Diámetro de entrada de 20 mm.

€ 105,00



03735NR

## Gear knob

Pomello in alluminio standard (no adatto a innesto a siringa). Tubo di alluminio nero o anodizzato con o-ring antiscivolo regolabile in altezza di oltre 10 cm per mezzo di contro ghiera filettata, completo di viti e istruzioni, diametro imbocco 15 mm.

Aluminum gear knob standard (not suitable for syringe engagement). Black or anodized aluminum tube, with anti-slip o-ring. Height adjusting (more than 10 cm) with additional part. Complete with screws and instructions. Fitting diameter: 15 mm.

Pomo de aluminio standard (no apropiado para acoplamiento sistema jeringa). Tubo de aluminio negro o anodizado con junta tórica antideslizamiento. Regulables en altura de más de 10 cm por medio de anillo contra roscado. Completo con tornillos e instrucciones. Diámetro de entrada de 15 mm.



€ 88,00

03734NR

# NAVIGA

Lastra di 5 mm anodizzata argento tagliata al laser. Pre-forata per un rapido fissaggio sull'autoveicolo o sulla pedana MAT, inclinazione regolabile. cm 36 x 28 circa. Made in Italy.

5 mm anodized aluminium sheet, laser cutted. Pre drilled for easy fitting on the floor, or on the MAT floor, adjustable angle; dimensions about cm 36 x 28. High quality materials.

Placa de 5 mm anodizada plata, cortada con láser. Preagujerada para una rápida fijación sobre el vehículo o la plataforma MAT, inclinación regulable. dim. 36 cm. x 28 cm. aproximadamente.

€ 120,00



03789TAN

# MATT

Lastra di 5 mm anodizzata argento tagliata al laser. Pre-forata per un rapido fissaggio sull'autoveicolo. cm 50 x 38 circa.

5 mm anodized aluminium sheet, laser cutted. Pre drilled for easy fitting dimensions about cm 50 x 38. High quality materials.

Placa de 5 mm anodizada plata, cortada con láser. Preagujerada para una rápida fijación sobre el vehículo, dim. 50 cm. x 38 cm. aproximadamente.

€ 120,00



03789RAN

# CARBON

Set 3 pezzi, in misto carbonio. Precurvate. Freno e frizione con inserti antiscivolo.

3-piece set in pre-bent and shaped mixed carbon. Brake and clutch with non-slip inserts

€ 74,00

Juego de 3 piezas, de misto carbonio. Curvados previamente. Freno y embrague con aplicaciones antideslizamiento.



03783L (NO ECE)

037521FPLNR

PREZZI IVA ESCLUSA  
VAT NOT INCLUDED - PRECIOS SIN IVA

PERFORMANCE

309

PREZZI IVA ESCLUSA  
VAT NOT INCLUDED - PRECIOS SIN IVA

PERFORMANCE

308

## Distanziali Spacers Distanciadores de ruedas

Prodotti in speciale lega d'alluminio mediante un'innovativa tecnologia di forgiatura, sono successivamente lavorati con macchine a controllo numerico per ottenere la perfetta coplanarità. Vengono inoltre sottoposti ad un ulteriore trattamento termico per incrementare la resistenza meccanica e successivamente anodizzati per garantire la protezione dall'ossidazione. Disponibili in un'ampia gamma d'applicazione, vengono forniti completi di bulloni ruota e viti per il fissaggio al mozzo della ruota. L'adozione di distanziali ruota determina l'incremento della carreggiata migliorando la precisione nella guida rendendo la vettura più facile, sicura e piacevole da guidare.

**Importante: l'adozione dei distanziali modifica la geometria delle sospensioni, che necessitano per tanto di una successiva revisione dell'assetto.**

Developed in a special aluminium alloy through an innovative forging technology, afterwards they are wrought with CNC machine (computer numerical control) to obtain the perfect coplanar surface. They are heat treated to increase the mechanical resistance and next they are anodized to guarantee the oxidation protection. The application table includes the most popular application available in the market, bolts and studs included. The wheel spacers increased the track improving the driving precision.

**Important: the use of wheel spacers modify the suspension geometry, that needs to be revised afterwards.**

Desarrollados con una aleación de aluminio especial mediante una tecnología innovadora de moldeado, se ha forjado con una máquina CNC controlada por ordenador para conseguir un acabado perfecto en la superficie.

Son tratados bajo temperatura para aumentar la resistencia mecánica e inmediatamente anodizados para garantizar la protección contra la oxidación. Disponibles en una alta parte del mercado, incluyen tornillos y tuercas. El uso de distanciadore de ruedas mejora la conducción en calzada y la sensación de placer en la conducción.

**Importante: el uso de distanciadore de ruedas modifica la geometría de la suspensión, que necesitará una revisión inmediata.**

## Tappi serbatoio Aero fuel caps Tapón aeronáutico

Cromato. Chromed. Cromado

€ 149,00



27004CR

Oss. Argento. Silver-Oss. Plata

€ 130,00



270040A

€ 32,00



27009G

PER LA LISTA APPLICAZIONI CONSULTARE IL LISTINO.  
FOR THE APPLICATION LIST PLEASE CHECK PRICE LIST.  
PARA LA LISTA DE LAS APLICACIONES,  
CONSULTESE EL LISTIN.

## HP300

Filtro aria universale. Sviluppato per vetture fino a 300 hp di potenza. Kit di montaggio universale incluso. Necessita la modifica all'impianto di aspirazione.

Universal air filter. Intended for cars which develop up to 300 bhp. Includes universal assembly kit. Requires some modification of the air intake assembly.

Filtro de aire universal. Desarrollado para automóviles de hasta 300 hp de potencia. Juego de montaje universal incluido. Precisa una modificación de equipo de aspiración.

€ 185,00



€ 77,00

Filtro HP300 - HP300 Filter - Filtro de aire HP300

030HP002



030HP300

## HP160

Filtro aria universale. Sviluppato per vetture fino a 160 hp di potenza. Kit di montaggio universale incluso. Necessita la modifica all'impianto di aspirazione.

Universal air filter. Intended for cars which develop up to 160 bhp. Includes universal assembly kit. Requires some modification of the air intake assembly.

Filtro de aire universal. Desarrollado para automóviles de hasta 160 hp de potencia. Juego de montaje universal incluido. Precisa una modificación de equipo de aspiración.

€ 159,00



€ 65,00

Filtro HP300 - HP300 Filter - Filtro de aire HP300

030HP003



030HP160

Tubo di connessione per HP300 e HP160.  
Connection tube for HP300 and HP160.  
Tubo de conexión para HP300 y HP160.

€ 130,00



030HP001

Detergente  
Cleaner  
Detergente

€ 14,00



030AC005

## Battitacco Sill guard Para umbrales



Set 2 battitacco 3D resinati adesivi  
Set of 2 sill guard 3D flexible adhesive  
Set 2 adhesivos flexibles para umbrales 3D.

605 x 35 mm  
€ 35,00

03769A

450 x 35 mm  
€ 35,00

03769B



Set 2 battitacco 3D carbon adesivi  
Carbon sill guard 3D flexible adhesive  
Set de 2 adhesivos en carbón para umbrales 3D.

605 x 35 mm  
€ 50,00

03770CAR...

450 x 35 mm  
€ 37,00

03769CAR...

# NEW STRADA

Set 4 tappeti in moquette  
2 taglie (A e B) con inserto vinile.

Set of 4 carpet  
in 2 sizes (A and B) with vinyl insert.

Set 4 alfombras moqueta,  
2 tallas (A o B) con insertos en vinilo.

€ 40,00

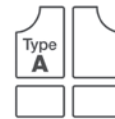

Per vetture con acceleratore  
tradizionale.  
Suitable for all cars with  
conventional accelerator.

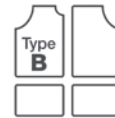

Per vetture con acceleratore  
a soletta.  
Suitable for all cars with  
floor accelerator.



## BASIC

Cuffia cambio in ecopelle con logo ricamato.  
Gear knob gaiter in ecological leather with Sparco embroidered logo.  
Fuelle cambio con botón de pulsación.

€ 36,00



037541NRRS

037541NRAZ

037541NRR

PER LA LISTA APPLICAZIONI COMPLETA CONSULTARE IL LISTINO  
i tappeti sparco sono adattabili ad ogni tipo di fondo dell'abitacolo,  
per tanto se non trovate la vostra vettura specifica potete  
acquistare il modello A oppure B per analogia di modello.  
FOR THE COMPLETE APPLICATION LIST  
PLEASE CHECK PRICE LIST  
PARA LA LISTA COMPLETA DE LAS APLICACIONES,  
CONSÚLTESE EL LISTÍN

DON'T FORGET TO USE IT  
Kit fissaggio universale  
per tappeti (box da 10 pz).  
Fixing universal kit.  
for carpet (10 pcs per box)  
Fijación universal  
para alfombra (10 pc/caja).



OPTIONAL  
10 PCS  
€ 37,50

03768PU



### Type A

03763ARS

03763ABS

03763AAR

03763ANR

### Type B

03763BRS

03763BBS

03763BAR

03763BNR

## GANCI COFANO BONNET PINS CIERRES CAPÓ

**01606S** - Coppia ganci a spillo in acciaio con spina guidata e chiusura a scatto. Pair of stainless steel bonnet pins with captive slide pin. Pareja de cierres capó de punzón, en acero con clavija y cierre de muelle.

**01606A** - Coppia ganci a spillo in alluminio anodizzato blu o rosso con spina guidata e chiusura a scatto. Pair of aluminium bonnet pins, anodised blue or red with captive slide pin. Pareja de cierres capó de punzón, en aluminio anodizado azul o rojo con clavija y cierre de muelle.

**01608** - Coppia ganci a molla in acciaio inossidabile. Pair of stainless steel spring hooks. Pareja de cierres capó de muelle de acero inoxidable

€ 21,50



01606S

01606AA

01606AR

01608

## PARASPRUZZI MUD FLAPS CHAPAS

Coppia paraspruzzi sagomati in polietilene da 1,5 mm di spessore. No FIA.

Curved polyethylene mud guards kit thickness 1,5 mm not FIA compliant.

Protección contra salpicaduras moldeado en polietileno de 1,5 mm de espesor no conforme con la FIA.

€ 12,50



03791

03791RS

03791AZ

03791NR



# TEAMWEAR





# SOFT SHELL



Taglia • Size • Tamaño: XS-XXL

€ 125,00

Soft shell in tessuto DROP TEX con felpatura interna.  
**COMPOSIZIONE:** 47% Poliammide 41% Poliestere 12% Elastane (spalmatura in Poliuretano) 350 g/m<sup>2</sup>.  
**CARATTERISTICHE:** Tessuto antigoccia e antivento, 3 tasche esterne e bordi polsini elasticizzati. Personalizzabile secondo guideline Sparco.

Soft shell DROP TEX with inside napping.  
**COMPOSITION:** 47% polyamide 41% polyester 12% elastane (polyurethane) 350 g/m<sup>2</sup>.  
**FEATURES:** Drop repellent and wind stopper fabric, 3 external pockets and elastic cuffs. It is possible to personalize this item with colours, printings and embroideries (Sparco guideline).

Chaqueta en tejido DROP TEX con sudadera al interior.  
**COMPOSICION:** 47% Poliammide 41% Poliestere 12% Elastane (revestimiento en Poliuretano) 350 g/m<sup>2</sup>.  
**CARACTERISTICAS:** Tejido antigota y antiviento, 3 bolsillos externos y malla elástica en las muñecas. Personalización según guideline Sparco.

011764NR..

011764BM..



# SWEATSHIRT



Taglia • Size • Tamaño: XS-XXL

€ 70,00

Felpa full zip in cotone con tasche laterali.  
**COMPOSIZIONE:** 100% Cotone smerigliato (garzatura interna) 310 g/m<sup>2</sup>.  
**CARATTERISTICHE:** Tessuto felpa in morbido cotone smerigliato con polsi, fondo e colletto a costina. Personalizzabile secondo guideline Sparco.

Full zip cotton sweatshirt with lateral pockets.  
**COMPOSITION:** 100% polished cotton (internal brushed) 310 g/m<sup>2</sup>.  
**CHARACTERISTICS:** Sweatshirt in soft polished cotton with cuffs and bottom ribs. It is possible to personalize this item with colours, printings and embroideries (Sparco guideline).

Sudadera full zip en algodón con bolsillos laterales.  
**COMPOSICION:** 100% Algodón (cepillado interno) 310 g/m<sup>2</sup>.  
**CARACTERISTICAS:** Tejido en felpa de algodón suave cepillado con muñequeras en malla. Personalización según guideline Sparco.

011756NR..

011756BM..



# POLO

# SHIRT

PREZZI IVA ESCLUSA  
VAT NOT INCLUDED - PRECIOS SIN IVA

PREZZI IVA ESCLUSA  
VAT NOT INCLUDED - PRECIOS SIN IVA



Taglia • Size • Tamaño: XS-XXL

€ 35,00

**COMPOSIZIONE:** 100% Cotone Piqué 190 g/m<sup>2</sup>  
**CARATTERISTICHE:** Tessuto piqué in morbido cotone traspirante con colletto a costina. Personalizzabile secondo guideline Sparco.

**COMPOSITION:** 100% cotton 190 g/m<sup>2</sup>  
**FEATURES:** Breathable cotton fabric. It is possible to personalize this item with colours, printings and embroideries (Sparco guideline).

**COMPOSICION:** 100% Algodòn "Piqué" 190 g/m<sup>2</sup>  
**CARACTERISTICAS:** Tejido "piqué" en algodòn suave transpirante con cuello en malla. Posibilidad de personalización según guideline Sparco).

011886NR.. 011886BM.. 011886BI..

Taglia • Size • Tamaño: XS-XXL

€ 70,00

**COMPOSIZIONE:** 100% Cotone 130 g/m<sup>2</sup>  
**CARATTERISTICHE:** Tessuto leggero e traspirante in cotone di alta qualità. Taschino porta penna. Personalizzabile secondo guideline Sparco.

**COMPOSITION:** 100% cotton 130 g/m<sup>2</sup>  
**FEATURES:** Lightweight and breathable cotton fabric. Pocket with pen holder. It is possible to personalize this item with colours, printings and embroideries (Sparco guideline).

**COMPOSICION:** 100% Algodòn 130 g/m<sup>2</sup>  
**CARACTERISTICAS:** Tejido ligero y transpirante en algodòn de muy buena calidad. Personalización según guideline Sparco).



011774BI..



TEAMWEAR

TEAMWEAR

320

321

# SH-17



Taglia • Size • Tamaño: 36-46

€ 89,00



**CARATTERISTICHE:** Scarpa bassa fashion in pelle leggera e tessuto traspirante con suola in TPR 100% riciclabile bicolore. Una scarpa tempo libero disegnata pensando alle linee caratteristiche di Sparco: le curve del passa cintura del sedile SPX sul tallone, quelle della spallina delle tute Sparco nei laterali ed il dettaglio del passa cinture R100S come passa laccio.

**CHARACTERISTICS:** Fashionable low shoe made of light leather and breathable fabric with two-tone recyclable 100% TPR sole. A leisure shoe designed with Sparco's typical features: curves like those on the SPX seatbelt slider on the heel, the curves of the Sparco racing suits on the shoulder parts on the sides and the detail of the R100S seatbelt fastener as the lace holes.

**CARACTERÍSTICAS:** Zapato bajo de piel ligera y tejido transpirable con suela en TPR 100% reciclable bicolor. Un zapato para el ocio diseñado pensando en las líneas características de Sparco: las curvas de la presilla del cinturón del asiento SPX en el talón, las del tirante de los monos Sparco en los laterales y el detalle de la presilla R100S como presilla para el cordón.



001262..SIAZ



001262..BM



001262..NRRS



001262..NR

# SL-17



NEW

Taglia • Size • Tamaño: 36-46

€ 70,00



**CARATTERISTICHE:** Scarpa bassa fashion in pelle leggera con suola racing P6. Una scarpa tempo libero disegnata pensando alle linee caratteristiche di Sparco: le curve del passa cintura del sedile SPX sul tallone, quelle della spallina delle tute Sparco nei laterali ed il dettaglio del passa cinture R100S come passa laccio. Fussbet con shock absorber rivestito.

**CHARACTERISTICS:** Fashionable low shoe made of light leather with P6 racing sole. A leisure shoe designed with Sparco's typical features: curves like those on SPX seatbelt slider on the heel, the curves of the Sparco racing suits on the shoulder parts on the sides and the detail of the R100S seatbelt fastener as the lace holes.

**CARACTERÍSTICAS:** Zapato bajo de piel ligera con suela racing P6. Un zapato para el ocio diseñado pensando en las líneas características de Sparco: las curvas de la presilla del cinturón del asiento SPX en el talón, las del tirante de los monos Sparco en los laterales y el detalle de la presilla R100S como presilla para el cordón.



001263..BINR



001263..NRBI



001263..AZBI



001263..NRRS

# UNIVERSE



Borsone grande trolley. Tessuto poliestere 600 con inserti in pelle sintetica. Base rinforzata. Fascia tracolla regolabile, maniglia a scomparsa. Manici in tessuto con chiusura in velcro imbottita. Portanome. Vano maggiore con doppia tasca interna a zip. Doppio fondo con chiusura a zip e rinforzi laterali abbattibili. Vano porta casco imbottito. Vano porta scarpe. Tasche porta documenti esterne laterali. con zip. Personalizzabile.

Large size trolley. 600 polyester fabric with synthetic leather inserts. Reinforced base. Adjustable shoulder strap. Retractable trolley handle. Padded carry handles with Velcro closure. Name holder. Large main compartment with double internal zip pocket. Double-bottomed with zip and removable lateral reinforcements. Padded helmet compartment. Shoes compartment. External lateral document holder with zip. Customizable.

Bolso grande trolley. Tejido de poliéster 600 con aplicaciones de piel sintética. Base reforzada. Correa bandolera ajustable. Trolley con asa escamoteable. Asas de tejido con cierre de velcro acolchado. Tarjetero para el nombre. Compartimento principal con doble bolsillo interior con cremallera. Doble fondo con cierre de cremallera y refuerzos laterales abatibles. Compartimento porta casco acolchado. Compartimento para zapatos. Bolsillos portadocumentos laterales exteriores con cremallera. Se puede personalizar.

H 40 x L 81 x P 35 . 110 Lt

€ 115,00



016429NR

# PLANET

H 35 x L 65 x P 30 . 68 Lt

€ 95,00

Borsone con trolley. Tessuto poliestere 600 con inserti in pelle sintetica. Base rinforzata. Fascia tracolla regolabile. Manici in tessuto con chiusura in velcro imbottita. Portanome. Vano maggiore con doppia tasca interna a zip. Tasca interna. Vano porta scarpe. Personalizzabile.

Wheeled bag. 600 polyester fabric with synthetic leather inserts. Reinforced base. Adjustable shoulder strap. Carry handles in fabric with Velcro padded closure. Name holder. Large main compartment with double internal zipped pocket. Internal pocket. Shoes compartment. Customizable.

Bolso con trolley. Tejido de poliéster 600 con aplicaciones de piel sintética. Base reforzada. Correa bandolera ajustable. Asas de tejido con cierre de velcro acolchadas. Tarjetero para el nombre. Compartimento principal con doble bolsillo interior con cremallera. Bolsillo interior. Compartimento para zapatos. Se puede personalizar.



016430NR

# SATELLITE

H 50 x L 35 x P 20 . 35 Lt

€ 95,00

Trolley, bagaglio a mano. Tessuto poliestere 600 e pelle sintetica. Tasca esterna frontale rimovibile con sistema zip ed utilizzabile come zaino, con spallacci e maniglia singola estraibile. Il vano separabile contiene una tasca porta pc imbottita con chiusura di sicurezza e vani porta oggetti. Tasca esterna posteriore e portanome. Maniglia telescopica con base rinforzata. Personalizzabile.

Cabin trolley. 600 polyester fabric and synthetic leather. Exterior removable front pocket zip usable as a backpack, with shoulder straps and single handle pull-out. Exterior rear pocket and name holder. Extendable handle. Customizable.

Trolley, maleta de mano. Tejido de poliéster 600 y piel sintética. Bolsillo exterior delantero desmontable con sistema de cremallera, que se puede utilizar como mochila, con tirantes y asa individual desmontable. El compartimento que se desmonta tiene un bolsillo para ordenador acolchado, con cierre de seguridad y espacio portabultos. Bolsillo exterior trasero y tarjetero para el nombre. Asa telescópica con base reforzada. Se puede personalizar.



016431NR

## TRIP3

H 35 x L 69 x P 37 . 89 Lt

€ 45,00

In tessuto poliestere con bordino in gomma a rinforzo sui lati. Piedini di appoggio in gomma. Tasca interna con chiusura zip. Molto capiente, ben organizzata, con tre diversi scomparti e zip. Bretella regolabile. Manici in tessuto con chiusura a velcro imbottita.

Trip3 Bag in polyester fabric with rubber edging and reinforcements on the sides. Rubber rest feet. Internal pocket with zip fastener. Very capacious, well-organised, with three different compartments and zips. Adjustable shoulder strap. Fabric handles with padded Velcro closure

Bolsa Trip3 de poliéster con franja de goma reforzada en los laterales. Pies de apoyo de goma. Bolsillo interno con cierre con cremallera. Muy amplia y bien organizada, con tres compartimentos diferentes y cremallera. Tirante regulable. Asas de tela con cierre con velcro acolchado.



016522NRGR

## STARS

H 40 x L 34 x P 20 . 27 Lt

€ 65,00

Zaino. Tessuto poliestere 600 con inserti in pelle sintetica. Schienale ergonomico e traspirante. Spallacci imbottiti. Tasche laterali e frontale porta oggetti. Ampia tasca frontale con rifiniture in pelle sintetica e vani porta carte, porta penne e tasca con zip. Tasca posteriore imbottita con porta pc, con chiusura di sicurezza, vani portaoggetti e tasca zip. Personalizzabile

Backpack. 600 polyester fabric with synthetic leather inserts. Ergonomic and breathable backrest. Padded shoulder straps. Lateral and front storage pockets. Large front pocket with synthetic leather finishes, document and pen holder compartment with zipped pocket. Laptop padded rear pocket with secure lock, storage compartment and zipped pocket. Customizable

Mochila. Tejido de poliéster 600 con aplicaciones de piel sintética. Panel de espalda ergonómico y transpirable. Tirantes acolchados. Bolsillos laterales y delantero portaobjetos. Amplio bolsillo delantero con acabados de piel sintética y compartimentos para papeles, bolígrafos y bolsillo con cremallera. Bolsillo trasero acolchado con porta PC, con cierre de seguridad, compartimentos portaobjetos y bolsillo con cremallera. Se puede personalizar



016432NRBI

## CODRIVER

NEW

H 35 x L 30 x P 10 . 10,5 Lt

€ 55,00

Borsa in Poliestere ultra resistente sviluppata con i co-driver Ingrassia e Andreussi. Dimensioni e spazi di contenimento interni studiati con i Co-driver, per l'inserimento di tutti gli strumenti necessari in gara. Doppia possibilità di chiusura, interno con fodera in contrasto per agevolare la ricerca è stato suddiviso in 2 scomparti ed è stata aggiunta una grande tasca con chiusura zip per riporre guanti e piccoli oggetti, all'interno sono presenti anche 6 tasche porta tessere. Tasca porta smartphone e tasca in PVC trasparente porta tabella oltre ad una tasca di medie dimensioni chiudibile con zip. La parte posteriore della borsa è stata accessoriata con nastri ed occhielli metallici che ne permettono il facile e flessibile ancoraggio ad ogni tipologia di rollbar attraverso l'uso di fascette. La borsa è fornita inoltre di una pratica tracolla.

Ultra-resistant polyester bag developed with the co-drivers Ingrassia and Andreussi. Dimensions and internal storage spaces designed with Co-drivers, to put all the tools necessary during the race. Double closure possibility, interior with contrasting lining to facilitate searching has been divided into 2 compartments and a large pocket with zip closure has been added for storing gloves and small items. Inside there are also 6 card pockets. Smartphone pocket and transparent PVC pocket for table, as well as a medium-sized pocket with zip closure. The back of the bag has straps and metal eyelets that allow it to be easily and flexibly anchored to any type of roll bar through the use of ties. The bag is also supplied with a practical shoulder strap.

Bolsa de Poliéster ultrarresistente, desarrollada con los copilotos Ingrassia y Andreussi. Las medidas y los espacios internos han sido estudiados con los copilotos para poder llevar todos los instrumentos necesarios durante la carrera. Doble posibilidad de cierre, interior con forro en contraste para facilitar la búsqueda, dividido en 2 secciones con añadido bolsillo grande con cierre de cremallera para poner los guantes y pequeños objetos, dentro también hay 6 bolsillos portatarjetas. Bolsillo para smartphone y bolsillo de PVC transparente donde poner la tabla además de un bolsillo de mediano tamaño cerrable con cremallera. La parte trasera de la bolsa se ha equipado con cintas y ojales metálicos que permiten el amarre, fácil y flexible, a todo tipo de rollbar por medio de correas. La bolsa también incluye una práctica bandolera.



0164281NR

## COSMOS

H 35 x L 35 x P 40 . 50 Lt

€ 65,00

Borsa porta casco e collare hans. Tessuto poliestere 600, neoprene e inserti in pelle sintetica. Sistema di asciugatura casco con alimentazione USB 12V. Soffietto per aumentare la capienza della borsa. Fascia tracolla regolabile. Due maniglie. Materiale resistente all'acqua. Copertura ventola.

Helmet and HANS bag. 600 polyester fabric, neoprene and synthetic leather inserts. Drying system helmet with USB 12V power. Divider to increase the capacity of the bag. Adjustable shoulder strap. Two carry handles. Water resistant material. Ventilation cover.

Bolso porta casco y collarín HANS. Tejido de poliéster 600, neopreno y aplicaciones de piel sintética. Sistema de secado del casco con alimentación USB 12V. Fuelle para aumentar la capacidad del bolso. Correa bandolera ajustable. Dos asas. Material resistente al agua. Cubierta del ventilador.



016433NR

sparco®

# MERCHANDISING



SI®

## HOODIE

Taglia • Size • Tamaño: S-XXL

€ 36,99

**COMPOSIZIONE:** 50 % cotone - 50% poliestere - felpata 280 g/m<sup>2</sup>.  
**CARATTERISTICHE:** Felpa con cappuccio foderato, cordoncino e pratica tasca marsupio anteriore. Spalle e giromanica con impuntura piatta. Stampa floccata.

**COMPOSITION:** 50 % cotton - 50% polyester - brushed 280 g/m<sup>2</sup>.  
**CHARACTERISTICS:** Sweatshirt with lined hood, drawstring and practical pouch pocket. Shoulders and underarms with flat stitching. Flock print.

**COMPOSICIÓN:** 50 % algodón - 50% poliéster - afelpado 280 g/m<sup>2</sup>.  
**CARACTERÍSTICAS:** Sudadera con capuchón forrado, cordón y práctico bolsillo marsupio delantero. Hombros y sisa con pespunte plano. Estampado floccado.



01227BM...

## HOODIE 1977

Taglia • Size • Tamaño: S-XXL

€ 36,99

**COMPOSIZIONE:** 50 % cotone - 50% poliestere - felpata 280 g/m<sup>2</sup>.  
**CARATTERISTICHE:** Felpa con cappuccio foderato, cordoncino e pratica tasca marsupio anteriore. Spalle e giromanica con impuntura piatta. Stampa floccata.

**COMPOSITION:** 50 % cotton - 50% polyester - brushed 280 g/m<sup>2</sup>.  
**CHARACTERISTICS:** Sweatshirt with lined hood, drawstring and practical pouch pocket. Shoulders and underarms with flat stitching. Flock print.

**COMPOSICIÓN:** 50 % algodón - 50% poliéster - afelpado 280 g/m<sup>2</sup>.  
**CARACTERÍSTICAS:** Sudadera con capuchón forrado, cordón y práctico bolsillo marsupio delantero. Hombros y sisa con pespunte plano. Estampado floccado.



01226BI...

## 1977

Taglia • Size • Tamaño: S-XXL

€ 36,99

**COMPOSIZIONE:** 50 % cotone - 50% poliestere - felpata 280 g/m<sup>2</sup>.  
**CARATTERISTICHE:** Morbida felpa girocollo dal taglio moderno con collo, polsini e orli a costina in elastane. Stampa floccata.

**COMPOSITION:** 50 % cotton - 50% polyester - brushed - 280 g/m<sup>2</sup>.  
**CHARACTERISTICS:** Soft modern crew neck sweatshirt with ribbed neck, wrists and hems in Lycra. Flock print.

**COMPOSICIÓN:** 50 % algodón - 50% poliéster - afelpado 280 g/m<sup>2</sup>.  
**CARACTERÍSTICAS:** Sudadera suave con cuello redondo de corte moderno con cuello, puños y dobladillos acanalados de elastano. Estampado floccado.



01225NR...

## HOODIE SEAL

Taglia • Size • Tamaño: S-XXL

€ 49,90

**COMPOSIZIONE:** 80% cotone - 20% poliestere.  
**COMPOSITION:** 80 % cotton - 20% polyester.  
**COMPOSICIÓN:** 80 % algodón - 20% poliéster.



01244NR

## HOODIE HERITAGE

Taglia • Size • Tamaño: S-XXL

€ 49,90

**COMPOSIZIONE:** 80% cotone - 20% poliestere.  
**COMPOSITION:** 80 % cotton - 20% polyester.  
**COMPOSICIÓN:** 80 % algodón - 20% poliéster.



01243NR



# POLO

**COMPOSIZIONE:** 100 % COTONE PIQUE' 180 g/m<sup>2</sup>.  
**CARATTERISTICHE:** polo in piqué con collo piatto a costina, grafiche con pregiati ricami, patch e stampe.

**COMPOSITION:** 100 % COTTON PIQUE 180 g/m<sup>2</sup>.  
**CHARACTERISTICS:** polo in cotton pique with flat ribbed neck, graphics with embroidery, patches and prints.

**COMPOSICIÓN:** 100 % ALGODÓN PIQUÉ 180 g/m<sup>2</sup>.  
**CARACTERÍSTICAS:** polo de piqué con cuello plano acanalado, gráficas con preciosos bordados, patch y estampados.

Taglia • Size • Tamaño: S-XXL

€ 31,99



01223NR...

01222BI...



# T-SHIRTS

**COMPOSIZIONE:**  
50% Poliestere / 25% Cotone / 25% Rayon  
**COMPOSITION:**  
50% Polyester / 25% Cotton / 25% Rayon

**COMPOSICIÓN:**  
50% Poliéster / 25% Algodón / 25% Rayon  
**Taglia • Size • Tamaño: S-XXL**



**CIRCUIT**

0000441...

€ 24,90



**CORPORATE**

0000392...

€ 24,90



**HANDCRAFTED**

0000651...

€ 24,90



**HERITAGE**

0000437...

€ 24,90



**PUNISH**

0000394...

€ 24,90



**RALLY**

0000662...

€ 24,90



**SEAL**

0000434...

€ 24,90



**VINTAGE 77**

0000403...

€ 24,90

**COMPOSIZIONE:** 100% Cotone.  
**COMPOSITION:** 100% Cotton.  
**COMPOSICIÓN:** 100% Algodón.

**Taglia • Size • Tamaño: S-XXL**



**1977**

01217BM...

€ 19,99



**1977**

01217BI...

€ 19,99



**DRIVER**

01218BI...

€ 19,99



**GO!**

01220AZ...

€ 19,99



**TRACK**

01215BM...

€ 19,99



**TRACK**

01215BI...

€ 19,99



**SKID**

01221AZ...

€ 23,99



**TRON**

01219NR...

€ 19,99

## FLEXFIT

**NEW** ORIGINAL CAP

Taglia • Size • Tamaño: S/M - L/XL

COMPOSIZIONE: 63% poliestere 34% cotone 3% P.U. spandex.  
COMPOSITION: 63% polyester 34% cotton 3% P.U. spandex.  
COMPOSICIÓN: 63% poliéster 34% Algodón 3% P.U. spandex.

€ 19,90



01245...



## REBEL

Taglia • Size • Tamaño: Single Size

COMPOSIZIONE: tessuto 100 % acrilico, chiusura regolabile in pvc.  
COMPOSITION: 100% acrylic fabric with pvc adjustable strap.  
COMPOSICIÓN: tejido 100 % acrílico con cierre regulable de pvc.

€ 13,99



01229NR

## 40<sup>TH</sup>

Taglia • Size • Tamaño: Single Size

COMPOSIZIONE: 97 % cotone - 3 % spandex elasticizzato.  
COMPOSITION: 97% cotton - 3% elasticised spandex.  
COMPOSICIÓN: 97 % algodón - 3 % spandex elasticizado.

€ 15,99



01231BM

## 1977

Taglia • Size • Tamaño: Single Size

COMPOSIZIONE: tessuto 100 % acrilico - mesh in poliestere con chiusura regolabile in pvc.  
COMPOSITION: 100% acrylic fabric - polyester mesh - with pvc adjustable strap.  
COMPOSICIÓN: tejido 100 % acrílico - malla de poliéster con cierre regulable de pvc.

€ 13,99



01230NR

## WINDY

Taglia • Size • Tamaño: Single Size

COMPOSIZIONE: tessuto 100 % acrilico.  
COMPOSITION: 100% acrylic fabric.  
COMPOSICIÓN: tejido 100 % acrílico.

€ 13,99



01232BMAZ

## SUNGLASSES

**NEW**



€ 49,00

099059

## UMBRELLA

Ombrello automatico in poliestere.  
Polyester automatic umbrella.  
Paraguas automático en poliéster.  
Ø 127 cm.

€ 16,00



099007



099047 Glove € 7,00

099049 Suit € 7,00

## SPARKY

H 41 cm.

€ 35,00



099051

Set da 10 porta Badge - Set of 10 badge  
Set de 10 chapas

€ 20,00



099BADGE

PREZZI IVA ESCLUSA  
VAT NOT INCLUDED - PRECIOS SIN IVA

## ANNIVERSARY

Cassa e fibbia in acciaio inox 316L. Diametro cassa 47 mm. Movimento automatico svizzero eta 2824/2 antimagnetico incabloc. Lunetta girevole in pvd nero. Corona a vite. Datario. Impermeabile 50 atm con valvola all'elio automatica. Quadrante e lancette in super-luminova. Vetro minerale. Fondello a vite.

€ 325,00



099057

Case and buckle: stainless steel 316L. Case diameter: 47 mm. Swiss made eta 2824/2 automatic and anti-magnetic incabloc movement. Black pvd rotating bezel. Screw-down crown. Date display. Water resistant 50 atm with automatic helium valve. White super-luminova dial and hands. Mineral glass. Screw back case.

Caja y hebilla en acero Inox 316L. Caja diámetro 47mm. Movimiento Automático Suizo ETA 2824/2 incabloc antimagnético. Bisel giratorio en PVS negro. Corona atornillada. Calendario. Resistencia al agua 50ATM con válvula automática de helio. Esfera y agujas de Superluminova. Cristal mineral. Tapa trasera atornillada.

€ 660,00



099035NR

€ 87,50



099013NR

099014BM

099014RS

€ 82,50



099016VI

099017NR

€ 185,00



099042GI

099042VE

099042AZ

€ 110,00



099043RS

099043VE

## WELCOME

NEW

€ 70,00



099058

## PADDOCK

Sedia paddock Sparco, struttura in alluminio con rivestimento in tessuto Oxford 600D. Braccioli imbottiti per maggiore confort. Pieghevole, comoda da trasportare.



The comfortable Sparco paddock Chair has an aluminium frame and is finished in coloured Oxford 600D fabric. The soft arms are padded for maximum comfort at all times. Easy to transport thanks to its folding mechanism.

Silla paddock Sparco, estructura de aluminio, revestimiento en tejido Oxford 600D. Mullidos brazos para el máximo confort. Se transporta cómodamente gracias a su mecanismo plegable.

€ 29,00



0990058

KIT 10 ADESIVI FUSTELLATI  
KIT OF 10 STICKERS  
KIT DE 10 ADHESIVOS

2 PCS 18 cm  
4 PCS 12 cm  
4 PCS 8 cm

€ 3,00

NEW



09003

## POUF

Morbido Pouf diametro 40 cm, altezza 40 cm, con Logo S stampato sulla seduta.

Soft pouf diameter 40 cm, height 40 cm, with printed S logo in the upper surface.

€ 55,00



0750006B

PREZZI IVA ESCLUSA  
VAT NOT INCLUDED - PRECIOS SIN IVA

MERCHANDISING

339

MERCHANDISING

338

# R100 S



**Poltrona Sparco R100S** - Replica del sedile Sportivo da auto Sparco, seduta ribassata e allargata per un maggiore comfort, schienale regolabile nell'inclinazione e con l'aggiunta della regolazione lombare, il sedile ha un dispositivo antiribaltamento con blocco dello schienale a 150°. La Poltrona Sparco è fornita completa di base con pistone certificato SGS / BIFMAX5.1 / EN1335, meccanismo basculante e base in alluminio lucidato con 5 solide ruote. I braccioli sono del tipo 4D con movimento multidirezionale.

€ 229,00

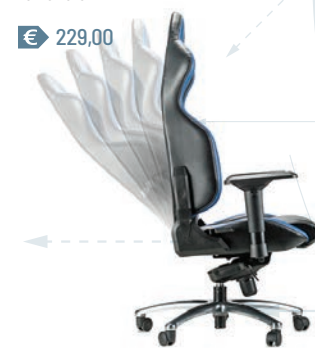

**Sparco R100S Armchair** - This replica of a Sparco race car seat has a lower, wider seat for maximum comfort, the back reclines, there is adjustable lumbar support and a mechanism that stops it from tipping over by preventing the back from reclining by more than 150°. The Sparco armchair comes complete with a polished aluminium base, an SGS / BIFMAX5.1 / EN1335 certified piston, a rocking mechanism and 5 sturdy wheels. The arms are type 4D with multi-directional movement.



**Sillón Sparco R100S** - Réplica del asiento Sportivo para coche de Sparco, tiene el asiento bajo y más ancho para aumentar el confort, la inclinación del respaldo es regulable y además ofrece la regulación lumbar, incorpora así mismo un dispositivo antivuelco que bloquea el respaldo a 150°. El Sillón Sparco se suministra con la base con pistón certificado SGS / BIFMAX5.1 / EN1335, mecanismo basculante y base de aluminio pulido con 5 ruedas robustas. Los brazos son del tipo 4D con movimiento multidireccional.

**Base girevole con ruote**, con pistone certificato SGS / BIFMAX5.1 / EN1335, meccanismo basculante e base in alluminio lucidato con 5 solide ruote, fissaggio con foro da 8,5 mm interasse di fissaggio 20 cm x 20 cm.

**Rotating base with wheels**, polished aluminium base with an SGS / BIFMAX5.1 / EN1335 certified piston, a rocking mechanism and 5 sturdy wheels, fixed with 8.5 mm holes on a 20 cm x 20 cm baseplate.

**Base giratoria con ruedas**, con pistón certificado SGS / BIFMAX5.1 / EN1335, mecanismo basculante y base de aluminio pulido con 5 ruedas robustas, fijación con agujero de 8,5 mm, distancia entre ejes de fijación 20 cm x 20 cm.

Kit di ricambio di 2 braccioli tipo 4D con movimento multidirezionale, fissaggio a vite M8 predisposto sotto al sedile R100S.

Spare parts kit with 2 type 4D arms with multi-directional movement, fixed with M8 bolts below R100S seat.

Kit de recambio de 2 brazos de tipo 4D con movimiento multidireccional, fijación con tornillo M8 prevista debajo del asiento R100S.



010702  
€ 99,00

010801  
€ 89,00



00975NRAZ

00975NRVD

00975NRNR

**sparco**<sup>®</sup>

# SEATS FOR SPORTS

**SAFETY & COMFORT  
FROM MOTORSPORT**



**ISI**<sup>®</sup>

# STADIUM & OFFICE SEATS

I sedili Sparco per lo sport nascono dall'esperienza di oltre 30 anni sui circuiti di tutto il mondo in ambito racing. Sparco, attraverso la sua esperienza in Ricerca & Sviluppo ha creato una seduta confortevole e anatomica per tutte le esigenze e per tutti gli atleti, professionisti e non, partendo dai sedili racing usati nel campionato del Mondo Rally (WRC) fino ad arrivare ad un sedile caratterizzato da elevate prestazioni con ottimo rapporto rigidità/peso. Caratteristiche fondamentali sono l'imbottitura e le schiume ad alta densità a memoria di forma, studiate per migliorare la postura dell'atleta in fase di riposo.

## Un mondo di possibilità per te:

Le panchine possono essere personalizzate con loghi e con tantissimi colori a disposizione: tutto ciò che devi fare è inviare a Sparco il logo della società ad alta definizione, a tutto il resto ci penseranno gli uffici grafici Sparco per realizzare la seduta perfetta per le tue esigenze. Si può includere il nome e cognome del proprio affiliato, del proprio presidente, o di qualsiasi persona che voglia la propria seduta unica: è per questo che i sedili non sono solo per panchine sportive, ma possono diventare comode poltrone da ufficio, per sale riunioni o per conferenze stampa.

Un mondo di colori e di possibilità ti aspettano, e se non ti basta tutto ciò che Sparco può offrirti sulla carta, prova il nuovo configuratore Sparco online, le possibilità di personalizzazione sono infinite.

Sparco sport seats stem from the experience of over 30 years on tracks around the world in the racing field. Sparco, through its R&D experience, has created a comfortable and anatomic seat for all needs and for all athletes, whether professional or amateur, starting from the racing seats used in the World Rally Championship (WRC) to achieve a seat characterized by high performance with excellent rigidity/weight ratio. Fundamental features are the padding and high density memory foams, designed to improve the posture of the athlete while resting.

## A world of possibilities for you:

The benches can be customised with logos and with many the colours available: all you have to do is send the high definition company logo to Sparco and everything else will be taken care of by the Sparco graphics department to implement the perfect seating for your needs. You can include the name and surname of your affiliate, your chairman or anyone who wants their own unique seat: that's why the seats are not just for sports benches, but can become comfortable chairs for the office, meeting rooms or press conferences

A world of colours and possibilities await you, and if everything that Sparco provides on paper does not satisfy you, try the new Sparco online configurator, the customization possibilities are infinite

Los asientos Sparco para el deporte nacen de la experiencia de más de 30 años en los circuitos de racing de todo el mundo. Sparco, a través de su experiencia en Investigación y Desarrollo, ha creado un asiento cómodo y anatómico para todas las exigencias y para todos los atletas, sean ellos profesionales o no, que van desde los asientos racing utilizados en el campeonato Mundial de Rally (WRC) hasta llegar a un asiento caracterizado por elevadas prestaciones, con una óptima relación de rigidez/peso. Características fundamentales son el relleno y las espumas de alta densidad con memoria de la forma, estudiadas para mejorar la postura del atleta en la fase de reposo.

## Un mundo de posibilidades para ti:

Los asientos se pueden personalizar con logotipos y con muchos colores a disposición: lo único que debes hacer es enviar a Sparco el logo de la empresa en alta definición; de todo lo demás se ocupan las oficinas gráficas de Sparco, para hacer el asiento perfecto para tus exigencias. Es posible incluir el nombre y el apellido del afiliado, del presidente, o de cualquier otra persona que quiera tener un asiento exclusivo: por eso, los asientos no son solamente para bancos deportivos, sino que se pueden convertir en cómodos sillones de oficina, de salas de reuniones, o para conferencias de prensa.

Un mundo de colores y de posibilidades te esperan y, si todo ello no fuera suficiente, Sparco te puede ofrecer su "mapa", prueba el nuevo configurador Sparco online, verás que las posibilidades de personalización son infinitas.

OFFICIAL SUPPLIER:



PALLAVOLO PADOVA

trentino volley



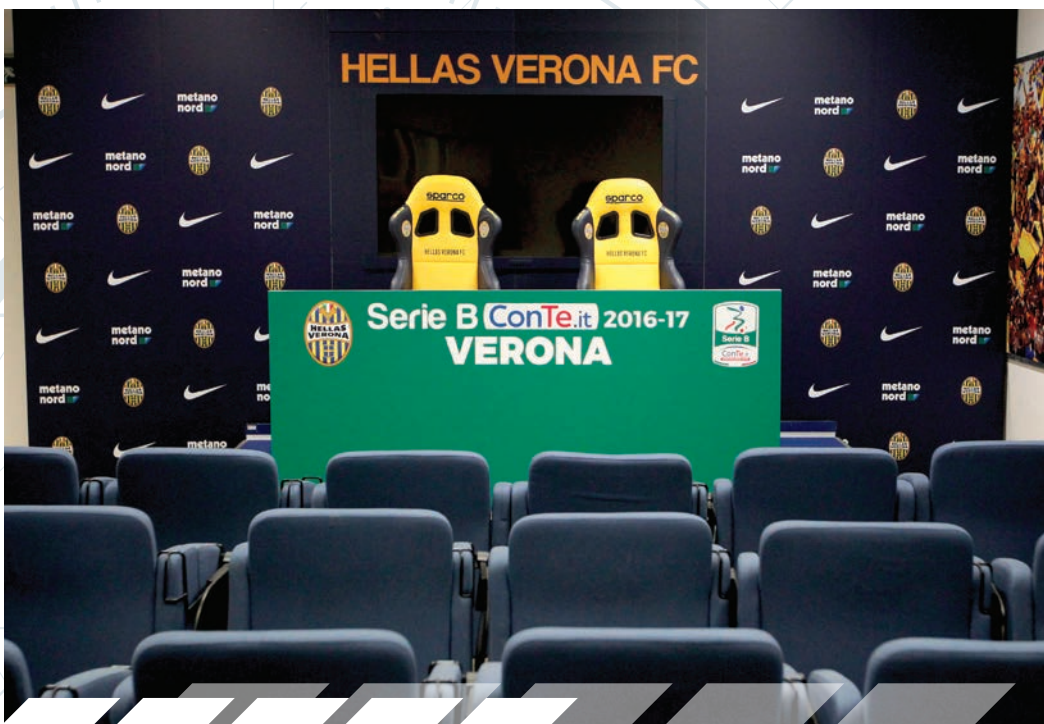





# OFFICIAL COLLECTIONS & LICENSING

Da oltre 40 anni leader sulle piste e i tracciati di tutto il mondo, SPARCO® cerca l'eccellenza e condivide i suoi valori attraverso speciali collezioni realizzate direttamente, Teamwork e Gaming, o su licenza da prestigiosi partner internazionali. Qualità, stile e sicurezza si consacrano in nuove realtà, dalle scarpe antinfortunistica alla sicurezza per l'infanzia, dalla cura dell'auto ai cerchi, dall'intrigante mondo fashion al mondo virtuale dei gamer.

SPARCO® leader of more than 40 years' standing on the world's of tracks, pursues excellence and shares its underlying values through special collections made directly, Teamwork and Gaming, or licensed by prestigious international partners. Quality, style and security are consecrated in new realities, from safety shoes to childhood protection, from car care to wheels, from the intriguing fashion industry to the virtual world of gamers.



Sparco Teamwork è la collezione di prodotti per la sicurezza sul lavoro firmata SPARCO®, pensata per offrire a tutti gli utilizzatori una gamma dallo stile Racing esaltando leggerezza, confort e sicurezza. Calzature e prodotti di assoluta qualità, realizzati nel pieno rispetto delle normative comunitarie vigenti relative ai dispositivi di protezione individuale. Sicurezza, massimo confort e design italiano, inconfondibilmente Racing.

Sparco Teamwork is the safety collection by SPARCO® designed to offer all consumers a Racing style range which is lightweight, comfortable and safe. High quality Footwear and products, manufactured in full compliance with current regulations on personal protective equipment. Safety, comfort and Italian Design, in unmistakable Racing style.

SPARCO® Gaming nasce per rendere l'esperienza della "simulazione" e del gaming sempre più vicina alla realtà. La collezione è rivolta ai gamer più "casual" sino all'utente che cerca prestazioni elevate, come ad esempio gli atleti dell'eSport. SPARCO® Gaming ha concepito tre modelli di sedute gaming; un cockpit Evolve; un guanto Hypergrip, progettato sia per un utilizzo con volantini di materiali vari che per i controller da PC e console e una t-shirt GT Vent, 100% personalizzabile.

SPARCO® Gaming is born to make the experience of the 'simulation' and gaming ever closer to reality. The collection aimed not only at the "casual" gamer, but also for the experienced user seeking high performance, such as eSports athletes. SPARCO® Gaming has conceived three gaming chair models, a cockpit Evolve; a glove Hypergrip, designed for use both with the steering wheels in various materials and with PC controllers and consoles and a t-shirt GT Vent, 100% customized.



by CAR PARTS DESIGN • carpadding.net

**CARPA DESIGN**

Collezione di accessori auto per migliorare la praticità, il confort e lo stile dell'auto fuori dalle piste.  
A collection of car accessories to enhance functionality, comfort and style off the tracks

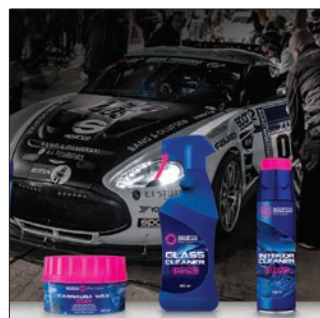

by CAR PARTS DESIGN • carpadding.net

**CARPA DESIGN**

Collezione di articoli per la cura e la protezione dell'auto per la massima performance e uno stile scintillante.  
A collection of car care and protection accessories for maximum performance and a dazzling style.



by BRANDSDISTRIBUTION • sparcofashion.com

**brandsdistribution.com**

Collezione di calzature e capi spalla dallo stile unico e dal design italiano. Dedicata agli sportivi che non rinunciano all'eleganza per un look "dopo gara".  
A unique collection of footwear and outerwear, and all Italian design. Dedicated to those athletes who enjoy sporting an elegant "after race" look.



by THRUSTMASTER • thrustmaster.com

**THRUSTMASTER®**

Collezione di volantini, accessori e periferiche per console e per PC sviluppate in collaborazione con TM, per portare la simulazione di guida ad un nuovo livello di performance.  
A collection of steering wheels, accessories and peripherals for consoles and PCs, developed in collaboration with TM, to bring simulation to a new level of performance.



by CAR PARTS DESIGN • carpadding.net

**CARPA DESIGN**

Collezione di seggiolini d'auto per garantire la massima sicurezza ai futuri piloti.  
A collection of car seats designed to ensure maximum safety for the drivers of the future.



by OZ RACING • sparco-wheels.com



Collezione cerchi in lega di alta qualità dal design MADE IN ITALY dedicati al mondo dell'after-market e ideali per il cambio di stagione.  
A collection of high quality alloy wheels designed for the after-market industry and for the changing seasons, and all rigorously MADE IN ITALY.



by SKG • skgitalia.com



Collezione di batterie ad alte prestazioni per auto e camion dallo stile inconfondibilmente Sparco.  
A collection of high-performing car and truck batteries, in true Sparco style.



by BHR HELMETS • sparcoriders.com



Collezione di caschi da moto dedicata a tutti gli sportivi delle 2 ruote che puntano alla sicurezza, al look dinamico e inconfondibilmente Sparco.  
A collection of motorcycle helmets dedicated to all 2-wheeler enthusiasts seeking safety combined with a dynamic look in true Sparco style.

# CONDIZIONI GENERALI DI VENDITA SPARCO

Le seguenti "Condizioni Generali di Vendita" sono riferite a tutti i contratti di vendita e di fornitura aventi per oggetto prodotti SPARCO o prodotti di altro marchio inclusi nei cataloghi SPARCO, laddove SPARCO S.p.A. è fornitore del Compratore, senza alcun diritto di esclusività territoriale che può essere oggetto di uno specifico contratto scritto.

Eventuali modifiche scritte alle seguenti condizioni generali di vendita, concordate ed accettate solo in forma scritta tra SPARCO S.p.A. ed il Compratore, saranno valide in caso di conflitto.

## 1. TRASMISSIONE ORDINE

- 1.1. Gli ordini devono essere trasmessi per scritto al Servizio Clienti SPARCO (accettati fax e posta elettronica), salvo se direttamente inseriti tramite connessione Internet con il sistema SPARCO. Eccezionalmente gli ordini possono essere accettati verbalmente ma devono essere confermati per scritto entro le successive 24 ore. In mancanza di conferma scritta, SPARCO non accetterà reclami per errori o incomprensioni.
- 1.2. L'ordine è confermato in forma scritta da SPARCO solo se espressamente richiesto dal Compratore al momento dell'ordine o se registrato dal Compratore direttamente tramite connessione Internet. In mancanza di specifiche istruzioni del Compratore, l'ordine è considerato accettato da SPARCO, salvo diversa comunicazione da parte di SPARCO.
- 1.3. Gli ordini per articoli speciali sono accettati solo se completi di dettagli per la produzione e devono fare riferimento a precedente offerta ufficiale. Il Compratore è responsabile per eventuali produzioni errate o non conformi causate da errate informazioni fornite per la produzione; il Compratore dovrà pagarne prezzi pattuiti e relative fatture anche in caso di errata produzione causata da errate informazioni fornite. Per ordini di articoli speciali, SPARCO si riserva il diritto di richiedere il pagamento anticipato della fornitura. Nel caso di ordini speciali e personalizzati con loghi, SPARCO non sarà in alcun modo responsabile dell'eventuale utilizzo di loghi né di qualsivoglia violazione perpetrata nei confronti delle norme che regolano espressamente il loro utilizzo e/o di eventuali diritti vantati dal proprietario dei loghi e/o di eventuali terzi. Il richiedente la produzione speciale e/o l'apposizione di loghi sui prodotti di SPARCO dichiara di (i) essere a conoscenza della normativa vigente relativa all'utilizzo dei loghi e delle conseguenze di eventuali violazioni della suddetta normativa e (ii) di manlevare SPARCO di qualsivoglia responsabilità derivante da o connessa con l'utilizzo dei loghi sui prodotti di SPARCO.

## 2. TERMINI DI CONSEGNA

- 2.1. La consegna della merce è da intendersi "franco stabilimento SPARCO" anche nel caso in cui la merce sia spedita in "porto franco": con la spedizione della merce si trasferiscono al Compratore tutti i rischi inerenti ai prodotti acquistati.
- 2.2. Nel caso in cui un termine di consegna sia dato, questo è da considerarsi indicativo ed è esclusa la facoltà del Compratore di domandare somme a titolo di risarcimento del danno derivante da ritardata consegna dei prodotti.

## 3. GAMMA DI PRODOTTI, PREZZI E PAGAMENTI

- 3.1. I prodotti illustrati sui cataloghi e/o i listini prezzi SPARCO sono indicativi in quanto SPARCO si riserva il diritto di modificare la gamma, le specifiche ed i prezzi dei prodotti in qualsiasi momento. Qualora modifiche siano implementate dopo la conferma d'ordine, SPARCO ne darà tempestiva comunicazione al Compratore. In tal caso le parti si impegnano sin d'ora a rinegoziare l'ordine per raggiungere una reciproca soddisfazione. Reclami su prezzi e/o sconti non saranno presi in considerazione se non comunicati entro 15 giorni dalla data della fattura. Salvo esplicita dichiarazione, i listini prezzi non includono I.V.A., trasporto, tasse e dazi che rimangono a carico del Compratore.
- 3.2. È responsabilità del Compratore assicurarsi che i prodotti acquistati siano conformi alle regolamentazioni locali per l'uso stradale, il commercio e le usanze religiose.
- 3.3. Il pagamento è sempre da considerarsi anticipato prima della consegna, salvo specifico accordo scritto tra il Compratore e SPARCO. La proprietà dei prodotti SPARCO si trasferisce al Compratore con il buon fine del pagamento.
- 3.4. In caso di ritardato pagamento, il Compratore pagherà a SPARCO interessi di mora al tasso ufficiale di sconto BCE maggiorato di sette punti percentuali, ferma restando la possibilità di SPARCO di richiedere la risoluzione del contratto ed il risarcimento del danno.
- 3.5. Una fattura non pagata causerà l'immediata richiesta del pagamento anticipato delle forniture in corso, il blocco delle spedizioni e l'accettazione di nuovi ordini.

## 4. GARANZIA E PROCEDURE DI RESO

- 4.1. I prodotti SPARCO sono garantiti contro i difetti di fabbricazione per un periodo di due anni dalla data di acquisto. Ogni modifica o uso e manutenzione impropria come indicato sul libretto di Uso e Manutenzione (quando fornito) causerà l'annullamento della garanzia. La garanzia SPARCO esclude tutti i costi di manodopera e di trasporto. Il Compratore deve correttamente informare il consumatore delle condizioni di garanzia SPARCO e dell'uso e manutenzione dei prodotti SPARCO; SPARCO non può essere ritenuta responsabile per garanzia concessa dal Compratore ai suoi Clienti, per uso scorretto, errata installazione o manutenzione dei prodotti SPARCO da parte del consumatore.
- 4.2. Reclami per spedizioni danneggiate o furti devono essere comunicati allo spedizioniere prima dell'accettazione della merce presso il Compratore. Richieste di accrediti per danni e/o furti non saranno considerate in mancanza di riserva emessa sui documenti di trasporto nei confronti del trasportatore.
- 4.3. Difetti di fabbricazione devono essere notificati a SPARCO entro 40 giorni dalla data di spedizione. Per i difetti di materiale o fabbricazione, per qualsiasi ragione o conseguenza essi abbiano, SPARCO è tenuta alla sola sostituzione, riparazione o accredito dell'articolo difettoso, ad esclusiva scelta di SPARCO.
- 4.4. Tutti i reclami ed i resi in garanzia devono essere autorizzati in forma scritta da SPARCO prima del rientro; l'autorizzazione sarà concessa o rifiutata sulla base della descrizione del difetto/reclamo e/o in considerazione di fotografie digitali fornite dal Compratore. L'autorizzazione data al reso non è da considerarsi quale accettazione del reclamo o motivo di sostituzione. Nessun reso di merce sarà accettato per articoli fuori produzione o con omologazione scaduta, salvo per riconosciuti difetti di fabbricazione.
- 4.5. Tutti i resi di materiale devono pervenire a SPARCO "franco destino" e devono essere accompagnati da documenti di trasporto completi e corretti in tutti i dettagli (quantità/codice articolo/descrizione); il riferimento di Autorizzazione al Reso dato dal Servizio Clienti

SPARCO deve essere citato sui documenti di trasporto ed affisso in maniera evidente all'esterno dei colli contenenti i prodotti resi. Copia dei documenti di spedizione deve essere trasmessa via fax a SPARCO come pre-avviso della spedizione in arrivo. Documenti incompleti o insufficienti causeranno l'immediato rifiuto dell'invio ed i relativi costi saranno a carico del Compratore. Tutti gli articoli di abbigliamento, incluse tute ed abbigliamento sportivo devono essere lavati prima di essere resi per riparazione.

- 4.6. Tutti gli articoli resi che saranno ispezionati o riparati al di fuori della garanzia (es.: riparazione di sedili, ricariche estintori, ecc.) saranno resi al Compratore in "porto assegnato".

## 5. USO DEL MARCHIO SPARCO

- 5.1. SPARCO S.p.A. è proprietaria del marchio SPARCO (parola o dispositivo) ed ogni uso del marchio deve essere autorizzato in forma scritta da SPARCO S.P.A.
- 5.2. L'uso e la posizione del marchio SPARCO su pubblicità, siti web, articoli promozionali, stand espositivi, vetrine, insegne, cataloghi, etc. deve sempre essere preventivamente sottoposto ad approvazione della Direzione Brand SPARCO e deve sempre rispettare le linee guida approvate da SPARCO S.P.A.
- 5.3. La registrazione di ogni nome a dominio Internet contenente la parola SPARCO deve essere in proprietà di SPARCO S.P.A. ed il suo uso deve essere oggetto di specifico accordo di licenza d'uso.
- 5.4. L'uso del marchio SPARCO su prodotti terzi (licensing) è sotto la responsabilità della Direzione Brand SPARCO e sarà regolamentata da specifici contratti sottoscritti tra SPARCO S.P.A. e la parte terza.
- 5.5. L'uso di immagini di piloti e squadre che vestono/utilizzano prodotti SPARCO non è ammessa se non specificamente autorizzata dal pilota e/o dalla squadra.

## 6. OSSERVANZA DEL CODICE ETICO

- 6.1. Ai sensi delle disposizioni di cui al D. Lgs. 8 giugno 2001 n. 231, come di volta in volta modificato ed integrato (il "Decreto"), nonché dei principi, delle norme e degli standard previsti dal modello di organizzazione, gestione e controllo adottato da SPARCO ai sensi del Decreto (il "Modello") e del codice etico contenente i principi di etica aziendale adottato da SPARCO (il "Codice Etico"), SPARCO ha reso disponibile il Modello ed il Codice Etico sul sito internet di SPARCO, all'indirizzo [www.sparco.it](http://www.sparco.it).
- 6.2. SPARCO invita i propri clienti a consultare il Modello ed il Codice Etico, a rispettare i principi ed i valori contenuti nel Codice Etico ed a tenere una condotta in linea con il Modello, e comunque tale da non esporre Sparco al rischio dell'applicazione di sanzioni previste dal suddetto Decreto.

## 7. USO DEI LOGHI

- 7.1. Per poter utilizzare un logo (stemma societario, logo di sponsor, foto ecc.), è necessario essere possessori dei diritti sul logo stesso. Richiedendo a Sparco di replicare un logo, il cliente conferma:
  - a. Di essere autorizzato ad utilizzare il logo per scopi commerciali;
  - b. Di essere consapevole che Sparco non è responsabile dell'eventuale utilizzo del logo o dei logo tanto in violazione delle normative vigenti sull'uso dei logo quanto in violazione del logo in particolare e/o di eventuali diritti vantati dal proprietario del logo stesso e/o eventuali terzi;
  - c. Di essere a conoscenza che l'uso illecito di logo protetti da parte di terzi è punibile per legge con le sanzioni pecuniarie all'uopo previste.
- 7.2. In ogni caso Sparco non sarà responsabile dell'eventuale utilizzo dei logo o dei logo al di fuori delle norme di legge. Non sarà altresì responsabile di qualsivoglia violazione perpetrata nei confronti dei logo o delle norme che regolano espressamente l'utilizzo dei logo.

## 8. FORO COMPETENTE

Per qualsiasi controversia relativa alle presenti Condizioni Generali di Vendita ed alle vendite da esse disciplinate sarà esclusivamente competente il Foro di Milano.

# GENERAL SALES TERMS AND CONDITIONS

The following "general sales terms and conditions" are referred to all sales or supplies contracts concerning SPARCO's products or other branded products included into SPARCO catalogues, whereby SPARCO S.p.A. is the supplier, without any territorial exclusive right to the Buyer which could be subject to a separate written contract. Eventual modifications to the following general sales terms and conditions, agreed and accepted only in written between SPARCO S.p.A. and the Buyer, would be valid in case of conflict.

## 1. ORDER PROCESSING

- 1.1. Orders must be transmitted in written to SPARCO's Customer Service Office (fax or e-mails acceptable), unless directly processed through web connection to SPARCO database. Exceptionally, orders can also be accepted verbally but must be confirmed in written within the 24 hours. Missing written confirmation, SPARCO will not accept claims for misunderstanding and/or mistakes.
- 1.2. Order processing is confirmed in written by SPARCO only when specifically requested by the Buyer at time of order or if order is processed directly by the Buyer through web connection to SPARCO. Missing Buyer's instructions on order confirmation, the order is considered as accepted by SPARCO unless clearly rejected in written.
- 1.3. Orders for customized products are accepted only complete of details for production purposes and should refer to a former official quotation. Buyer is responsible for wrong or non-conform productions due to wrong supplied manufacturing details; Buyer will pay the agreed prices and relevant invoices also in case of wrong production due to wrong supplied manufacturing details. On orders for customized products SPARCO reserves the right to require advanced payment. For customized products requiring trademarks/logo, SPARCO shall not be held liable in any way whatsoever for the use of trademarks/logo, for any infringement whatsoever committed of any current laws or provisions, expressly regulating the relevant use and for possible rights claimed by the owner of the trademarks/logo and/or by third parties. Customer requiring customized products declares (i) to be aware of the laws currently in force relating to the use of the trademarks/logo and related consequences (ii) to hold SPARCO harmless against any consequence of possible infringements of the abovementioned laws.

## 2. DELIVERY TERMS

Delivery of supplies is considered as "ex-SPARCO's works" even if goods are rendered on pre-paid transport charges basis; all risks relevant to purchased products are transferred to the Buyer's charge at the moment of delivery. When a delivery time is given, this is to be considered as informative and SPARCO cannot be held responsible for any consequence caused by possible delay; any possible delay in delivering goods will not cause any penalties to SPARCO.

## 3. RANGE OF PRODUCTS, PRICES AND PAYMENTS

- 3.1. Products showed in SPARCO's catalogues and/or price lists are informative as SPARCO reserves the right to modify products' ranges and products' specifications and prices at any time. When modifications are implemented after order confirmation, SPARCO will timely inform the Buyer. In such case, the parties will re-negotiate the order for the mutual satisfaction. Claims on prices and/or discounts cannot be accepted if raised after 15 days from date of invoice. Unless otherwise specified, price lists do not include V.A.T., freight and insurance costs, taxes and duties which remain to the buyer's cost.
- 3.2. It is Buyer's responsibility to insure that imported products meet local laws and regulations on road use of products, trade and religious requirements.
- 3.3. Payments are always to be considered as advanced prior to delivery unless otherwise clearly agreed in written between SPARCO and the buyer. Properties of SPARCO's products is transferred to the Buyer after remittance has been fully cashed.
- 3.4. In case of delayed payments, the Buyer will pay interests to SPARCO according to BCE official rate increased by 7 % points dating from expire date and SPARCO reserves the right to require the Buyer the contract resolution and claims for eventual damages.
- 3.5. One unpaid invoice will immediately cause request of advanced payment of all pending supplies, all shipments of goods will be stopped and no fresh orders will be processed into the system.

## 4. WARRANTY AND RETURN POLICIES

- 4.1. SPARCO's products are guaranteed against workmanship and material defects for a period of up to two years from date of purchase. Any alterations or improper use or care of our products as detailed in the Use and Maintenance User's Manual, when supplied, will void the warranty. This warranty specifically excludes all labor and freight costs. Buyer must duly inform end users of SPARCO's warranty conditions and of SPARCO's products use and maintenance and cannot hold SPARCO responsible for his special warranty commitments with his Customers, for misuse, wrong application or maintenance of SPARCO's products by end-users.
- 4.2. Any claim for damaged consignments or stolen goods must be addressed to the carrier prior to acceptance of consignments at Buyer's premises. Without official claim to carrier, no refunds and/or reshipments for replacing damaged/stolen goods will be taken into consideration.
- 4.3. Any defect on brand new item has to be noticed to SPARCO within 40 days from shipping date. Any raw material defect or wrong execution in manufacturing, for whatever reason and whatever consequence this would involve, only oblige SPARCO to replace, repair, refund the faulty item at SPARCO's choice.
- 4.4. All warranty/service return must be authorized in written by SPARCO prior to return shipment; authorization will be considered and granted or refused based upon defect/claim description and/or digital pictures. Authorization granted for return will not be considered as acceptance to the claim or reason for replacement. No return will be accepted for discontinued items or with expired homologation, unless the return is due to manufacturing defects.
- 4.5. All returned shipments must be arranged on pre-paid freight and must be accompanied by proper documents and declarations for customs purposes and Authorization for Return ref.number must be indicated in shipping documents and prominently displayed on the outside of the package containing the returned products. Copy of shipping documents are to be faxed to SPARCO as pre-alert of incoming arrival. Should the documents be incomplete or insufficient goods will be refused and any expenses or duties will be at Buyer's charge. All returned clothing including suits and sportswear must be dry cleaned prior to sending for repair.

- 4.6. All returned items which will be inspected or repaired out of warranty as standard servicing (seats reconditioning, fire-extinguishers refilling, etc) will be reshipped to the Buyer at his charge.

## 5. USE OF SPARCO TRADE MARK

- 5.1. SPARCO S.p.A. is the registered owner of the SPARCO (word and/or device) trademark and any use of the trademark has to be authorized in written by SPARCO S.p.A.
- 5.2. The use and position of SPARCO trademark on all advertisements, web-sites, promotional, exhibition booths, windows signs, catalogues, etc. must always be submitted for approval to SPARCO's Brand Management and must always comply with the corporate guidelines approved by SPARCO S.p.A.
- 5.3. The registration of any Internet domain name containing SPARCO word must be made under the property of SPARCO S.p.A. and its use must be subject of a specific domain name licence agreement.
- 5.4. The use of SPARCO trademark on third parties' products (licensing) is under the responsibility of SPARCO's Brand Management and will rule under a specific legal contract to be signed between SPARCO S.p.A. and the third party.
- 5.5. The use of images of drivers and teams using SPARCO's products is not allowed unless specifically authorized by the driver and/or the team.

## 6. COMPLIANCE WITH THE ETHICAL CODE

- 6.1. Pursuant to Legislative Decree no. 231 of 2001, as amended and supplemented from time to time (the "Decree"), as well as to the principles, laws and standards provided for by the organizational, management and control model adopted by SPARCO pursuant to the Decree (the "Model") and to the ethical code setting out the standards of business ethics adopted by SPARCO (the "Ethical Code"), the Model and the Ethical Code as adopted by SPARCO are available on [www.sparco.it](http://www.sparco.it).
- 6.2. SPARCO invites customers to vision the Model and the Ethical Code, to respect the principles of the Ethical Code and to behave in accordance to the Model, and in anyway whatsoever so as not to expose SPARCO to the risk of application of the sanctions set forth in the Decree.

## 7. DISCLAIMER ON TRADE-MARKS

- 7.1. The use of a logo (brand name, trademark, etc.) is allowed when the user owns the rights on the logo. By requiring Sparco to replicate a logo, the customer declares:
  - a. To be allowed to use the logo for commercial purposes;
  - b. To acknowledge that Sparco is not liable for neither the infringement of the logo itself and/or any possible rights claimed by the owner of the logo and/or by third parties;
  - c. To be aware that the illicit use by third parties of any protected logos and trademarks is sanctioned by law by means of purposely established fines.
- 7.2. Sparco shall not be held liable in any way whatsoever for the use of any logo not complying with current laws nor for any infringement whatsoever committed in relation to any logo or of any current laws or provision, general or specific, expressly regulating the relevant use.

## 8. GOVERNING LAW AND JURISDICTION

These terms and conditions are constructed and enforced in accordance with the laws of Italy and any controversy raising shall be adjudicated upon exclusively by Milano (Italy) Court.

# CONDICIONES GENERALES DE VENTA

Las "Condiciones generales de venta" enumeradas a continuación aplican a todos los contratos de venta y suministro que tengan por objeto productos SPARCO o productos de otra marca incluidos en los catálogos SPARCO, donde SPARCO S.p.A. sea proveedor del Comprador, sin ningún derecho de exclusividad territorial que pueda ser sujeto a un contrato escrito específico. Eventuales modificaciones escritas respecto de las siguientes condiciones generales de venta, acordadas y aceptadas sólo en forma escrita entre SPARCO S.p.A. y el Comprador, serán válidas en caso de conflicto.

## 1. SOLICITUD DE PEDIDOS

- 1.1. Los pedidos deben ser solicitados por escrito al Servicio a Clientes SPARCO (se aceptan fax y correo electrónico), excepto en los casos en que el pedido se ingrese directamente a través de Internet con el sistema SPARCO. En forma excepcional, las órdenes podrán ser aceptadas verbalmente, pero deberán ser confirmadas por escrito dentro de las 24 hs. sucesivas. En ausencia de una confirmación escrita, SPARCO no aceptará reclamos por errores o malentendidos.
- 1.2. El pedido será confirmado por SPARCO en forma escrita sólo en el caso en que fuera expresamente solicitado por el Comprador en el momento del pedido, o si así lo hubiera registrado el Comprador directamente a través de Internet. En ausencia de instrucciones específicas del Comprador, el pedido se considerará aceptado por SPARCO, excepto comunicación contraria por parte de SPARCO.
- 1.3. Los pedidos de artículos especiales se aceptarán sólo cuando incluyan todos los detalles para la producción y se haga referencia a ofertas oficiales anteriores. El Comprador es responsable por eventuales producciones erróneas o no conformes causadas por información errada entregada para la producción. El comprador deberá abonar los montos pactados y correspondientes facturas incluso en caso de producción errónea causada por el suministro de información errada. Para órdenes de artículos especiales, SPARCO se reserva el derecho de solicitar el pago anticipado del suministro. En caso de pedidos especiales que llevan logos, SPARCO no será en ninguna manera responsable de la utilización de los logos ni siquiera de las violaciones perpetradas en contra de las reglas que rigen su utilización y/o eventuales derechos reclamados por los propietarios de los logos y/o de terceros. El solicitante de una producción especial y/o la colocación de logotipos sobre los productos declara estar al tanto de la legislación vigente sobre la utilización de los logos y de lo que consigue en caso de violación de la legislación misma y de liberar SPARCO de todas responsabilidades derivadas o conectadas a la utilización de los logos sobre los productos SPARCO.

## 2. TÉRMINOS DE ENTREGA

- 2.1. La entrega de la mercadería se entiende "franco fábrica SPARCO", incluso en el caso en que la mercadería se envíe franco de porte. Con la expedición de la mercadería se transfieren al Comprador todos los riesgos inherentes a los productos adquiridos.
- 2.2. En el caso en que se diera un plazo de entrega, éste se considera indicativo y se excluye la facultad del Comprador de demandar sumas a título de resarcimiento del daño derivado de la entrega demorada de los productos.

## 3. GAMA DE PRODUCTOS, PRECIOS Y PAGOS

- 3.1. Los productos ilustrados en los catálogos y/o listas de precios SPARCO son indicativos en cuanto SPARCO se reserva el derecho de modificar la gama, las especificaciones y los precios de los productos en cualquier momento. En el caso en que las modificaciones se implementen posteriormente a la confirmación del pedido, SPARCO enviará la correspondiente comunicación al Comprador. En tal caso, las partes se comprometen a partir de este momento a renegociar el pedido para llegar a una satisfacción recíproca. Los reclamos por precios y/o descuentos serán considerados siempre que se comuniquen dentro de los 15 días a partir de la fecha de la factura. Excepto declaración explícita, las listas de precios no incluyen IVA, transporte, impuestos y derechos de aduana, que quedan a cargo del Comprador.
- 3.2. Es responsabilidad del Comprador asegurarse de que los productos adquiridos cumplan con las normativas locales para el uso vial, el comercio y las usanzas religiosas.
- 3.3. El pago debe entenderse siempre como anticipado antes de la entrega, excepto acuerdo escrito específico entre el Comprador y SPARCO. La propiedad de los productos SPARCO se transferirá al Comprador una vez que se haya hecho efectivo el pago. En caso de demora en el pago, el Comprador pagará a SPARCO intereses de mora a la tasa oficial de descuento BCE con un aumento de siete puntos porcentuales, manteniendo SPARCO la posibilidad de solicitar la resolución del contrato y el resarcimiento del daño.
- 3.4. Una factura no pagada será causa de inmediata solicitud de pago anticipado de los suministros en curso, el bloqueo de los envíos y la aceptación de nuevos pedidos.

## 4. GARANTÍA Y PROCEDIMIENTO PARA DEVOLUCIÓN

- 4.1. Los productos SPARCO poseen garantía contra defectos de fábrica por un período de dos años desde la fecha de compra. Cada modificación o uso y mantenimiento inadecuados, como se indica en el manual de Uso y Mantenimiento (cuando se suministre) causará la anulación de la garantía. La garantía SPARCO excluye los costes de mano de obra y transporte. El Comprador debe informar correctamente al Consumidor acerca de las condiciones de garantía SPARCO y del uso y mantenimiento de los productos SPARCO. SPARCO no se hará responsable por garantía concedida por el Comprador a sus Clientes, por uso incorrecto, instalación errada o mantenimiento de los productos SPARCO por parte del consumidor.
- 4.2. Los reclamos por envíos dañados o hurtos deben ser comunicados al transportista antes de la aceptación de la mercadería por parte del Comprador en el destino de entrega. Las solicitudes de reembolso por daños y/o hurtos no serán consideradas en caso de ausencia de reserva emitida en los documentos de transporte respecto del transportista.
- 4.3. Los defectos de fábrica deben ser notificados a SPARCO dentro de los 40 días a partir de la fecha de envío. Por defectos de material o de fábrica, sin importar la causa o las consecuencias de los mismos, SPARCO se compromete a la sustitución, reparación o reembolso del artículo defectuoso, a elección exclusiva de SPARCO.
- 4.4. Todos los reclamos y las devoluciones en garantía deben ser autorizadas en forma escrita por SPARCO antes de que la devolución se haga efectiva. La autorización será concedida o denegada en base a la descripción del defecto/reclamo y/o considerando fotografías digitales suministradas por el Comprador. La autorización otorgada a la devolución no debe considerarse como aceptación del reclamo o motivo de sustitución. No se aceptará la devolución de mercadería por artículos fuera de producción o con homologación vencida, excepto por defectos de fábrica reconocidos.

- 4.5. Todas las devoluciones de materiales deberán arribar a SPARCO "franco destino" y con documentos de transporte completos y correctos (cantidad/código artículo/descripción). La referencia a la Autorización a la Devolución otorgada por el Servicio a Clientes SPARCO debe ser citada en los documentos de transporte y adjunta en forma evidente en el exterior de los paquetes que contengan los productos devueltos. Una copia de los documentos de envío debe ser enviada por fax a SPARCO como preaviso del envío en camino. Documentos incompletos o insuficientes serán causa del inmediato rechazo del envío y los costes relativos quedarán a cargo del Comprador. Todos los artículos de indumentaria, incluidos equipos y vestimenta deportiva deben ser lavados antes de ser devueltos para reparación.
- 4.6. Todos los artículos devueltos que sean inspeccionados o reparados fuera de garantía (Ej. reparación de butacas, recarga de extinguidores, etc.) serán devueltos al Comprador "porte debido".

## 5. USO DE LA MARCA SPARCO

- 5.1. SPARCO S.p.A. es propiedad de la marca SPARCO (palabra o dispositivo) y cada uso de la marca debe ser autorizado en forma escrita por SPARCO S.p.A.
- 5.2. El uso y la posición de la marca SPARCO en publicidades, sitios web, artículos promocionales, puestos expositivos, vitrinas, carteles, catálogos, etc. debe ser siempre sujeto preventivamente a la aprobación de la Dirección Brand SPARCO y debe siempre respetar los lineamientos aprobados por SPARCO S.p.A.
- 5.3. El registro de nombres de dominio de Internet que contengan la palabra SPARCO debe ser propiedad de SPARCO S.p.A., y su uso debe ser objeto de acuerdo específico de licencia de uso.
- 5.4. El uso de la marca SPARCO en productos de terceros (licencia) se encuentra bajo la responsabilidad de la Dirección Brand SPARCO y será reglamentada por contratos específicos firmados entre SPARCO S.p.A. y el licenciario.
- 5.5. El uso de imágenes de pilotos y equipos que vistán/utilicen productos SPARCO no es admisible si no es autorizada específicamente por el piloto y/o el equipo.

## 6. CUMPLIMIENTO DEL CODIGO DE ETICA

- 6.1. De conformidad con las disposiciones contempladas en el D.LGS 8 junio n. 231, de vez en cuando modificado y completado ("Decreto") y también de los principios, de las reglas y los estándares previstos por el modelo de organización, gestión y control adoptados por SPARCO de conformidad con el Decreto ("Modelo") y del código de ética que contiene los principios de ética de empresa adoptados por Sparco ("Código de Ética"), el Modelo y el Código de Ética de SPARCO esta disponible en su página internet [www.sparco.it](http://www.sparco.it)
- 6.2. SPARCO invita a sus clientes a la consulta del Modelo y del Código de Ética, al respecto de los principios y valores contenidos en el Código de Ética y a comportarse de acuerdo con el Modelo y de manera que no exponga SPARCO al riesgo de sanciones previstas en el Decreto.

## 7. UTILIZACION DE LOS LOGOS

- 7.1. Para poder utilizar un logo (emblema de la empresa, logo de los patrocinadores, imágenes etc.) es necesario ser dueño del logo mismo. Pidiendo a Sparco de hacer un logo el cliente confirma:
  - a. De tener autorización para utilizar dicho logo por fines comerciales
  - b. De ser consciente que Sparco no es responsable para la utilización del logo o de los logos tanto para violación de la legislación vigente sobre la utilización del logo cuanto para violación del logo y/o eventuales derechos del propietario del logo y/o eventuales terceros
  - c. De tener conocimiento que la utilización ilegal de logos protegidos por parte de terceros es sancionado por la ley con multas establecidas por este fin.
- 7.2. De toda manera Sparco no tendrá responsabilidad para eventual utilización de los logos fuera de la norma de ley. Tampoco será responsable de cualquier violación perpetrada contra los logos o de la legislación que regulan específicamente la utilización de los logos.

## 8. FORO COMPETENTE

Cualquier controversia suscitada en relación a las presentes Condiciones generales de venta y a las ventas por éstas reglamentadas será competencia exclusiva del Foro de Milano.



ISI<sup>®</sup>